



**LASER PRINTER  
PARTS REFERENCE LIST**

**MODEL:HL-820/1020/1040/1050**

**MECHANISMS & ELECTRONICS**

## NOTE FOR USING THIS PARTS REFERENCE LIST

1. In the case of ordering parts, it needs mentioning the following items:

- (1) Code
- (2) Q'ty
- (3) Description
- (4) Symbol ( PCB No., Revision , and Parts location mounted on the PCB.)

*Note : No orders without Parts Code or Tool No. can be accepted.*

< Example >

REF.NO.	CODE	Q'TY	DESCRIPTION	SYMBOL	REMARK

Revision No.: marked on the printed circuit board.

**B48K056 - 201A**

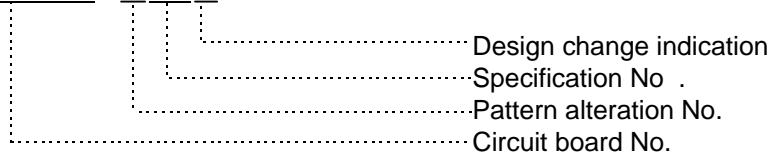

2. Design-changed parts :

If the parts are changed, any one of the following symbols is indicated in the REMARKS column.

- #A : compatible between old and new
- #B : replaceable from old to new
- #D : incompatible
- # : newly established

3. The original of this list was made based on the information available in April, 1998.

4. Parts are subject to change in design without prior notice.

# CONTENTS

GENERAL DRAWING .....	1
MAIN PCB DRAWING (HL-820/1020/1040) .....	2
MAIN PCB DRAWING (HL-1050) .....	3
AC CORD / PACKING MATERIAL DRAWING .....	4
1. DRIVE UNIT .....	5
2. SCANNER UNIT .....	5
3. MP SHEET FEEDER .....	6
4. FIXING UNIT .....	6
5. COVERS .....	7
6-1. MAIN PCB <HL-820/1020> .....	8
6-2. MAIN PCB <HL-1040 OTHERS> .....	8
6-3. MAIN PCB <HL-1040 ISRAEL> .....	8
6-4. MAIN PCB <HL-1050 OTHERS> .....	9
6-5. MAIN PCB <HL-1050 ISRAEL> .....	9
7. PANEL SENSOR PCB .....	10
8. POWER SUPPLY PCB .....	10
9. HIGH VOLTAGE POWER SUPPLY .....	11
10. AC CORD .....	11
11. ACCESSORIES .....	12
12. PACKING MATERIALS .....	12

GENERAL DRAWING

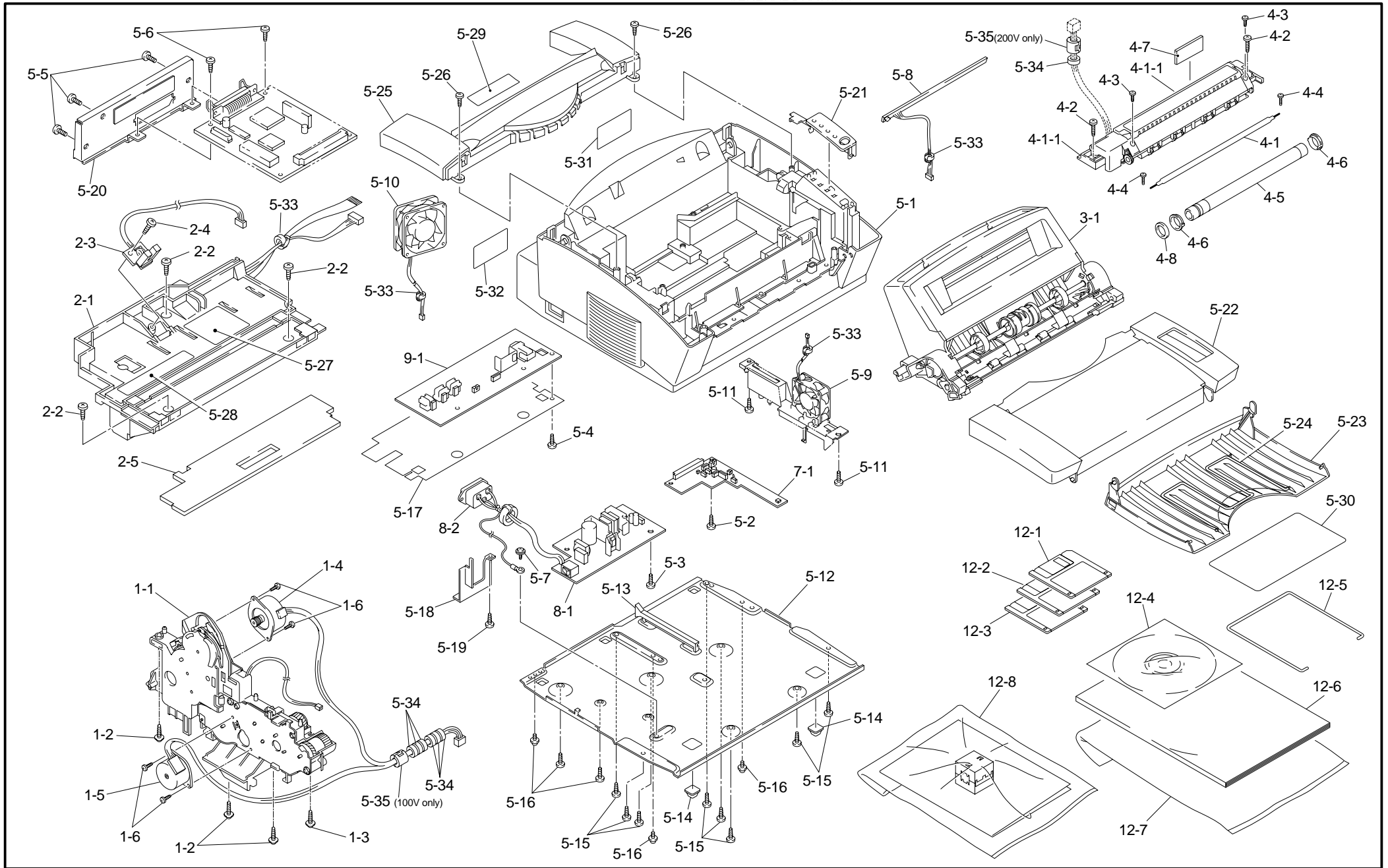

6-1. MAIN PCB <HL-820/1020>

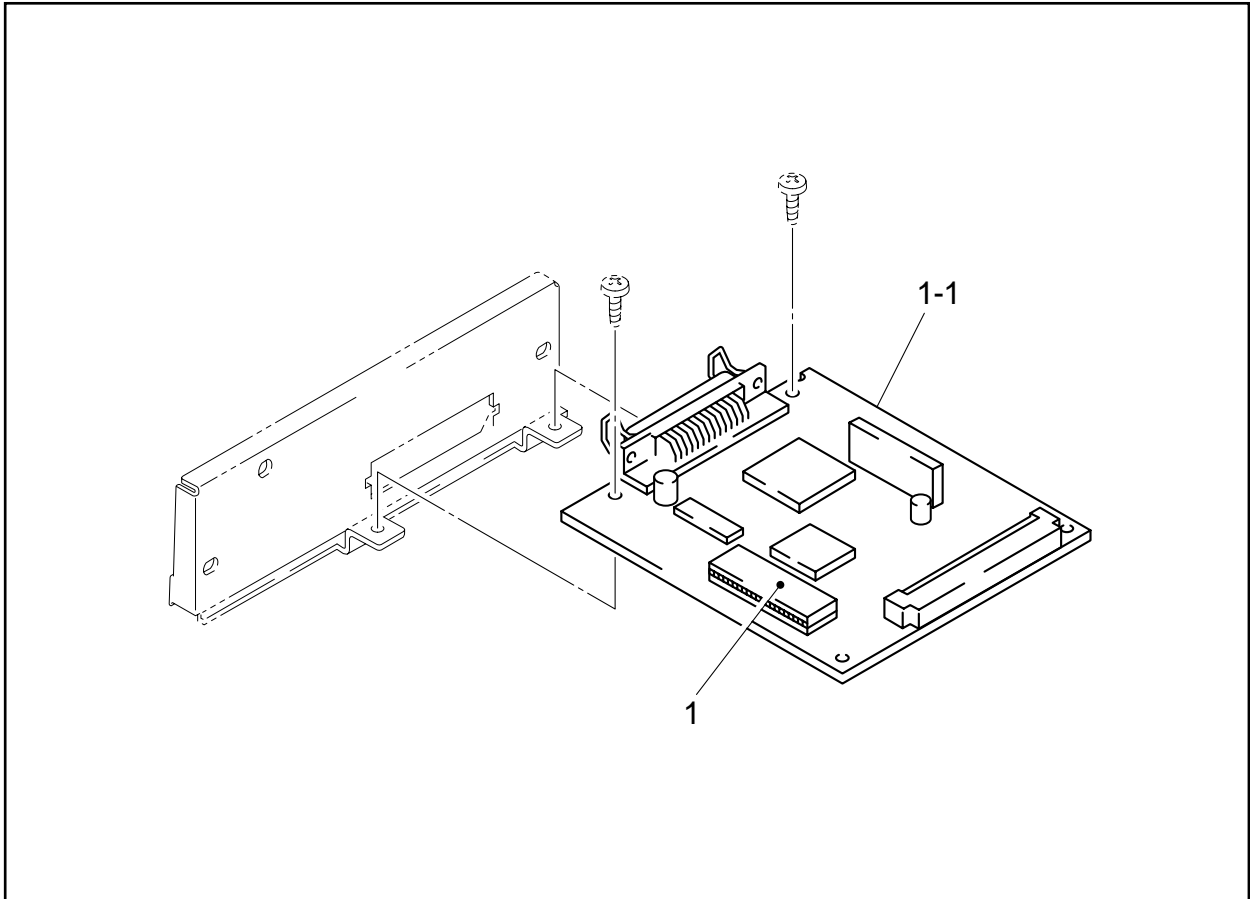

MODEL HL-820/1020 84U-821-101/104

6-2/3. MAIN PCB <HL-1040 OTHERS/ISRAEL>

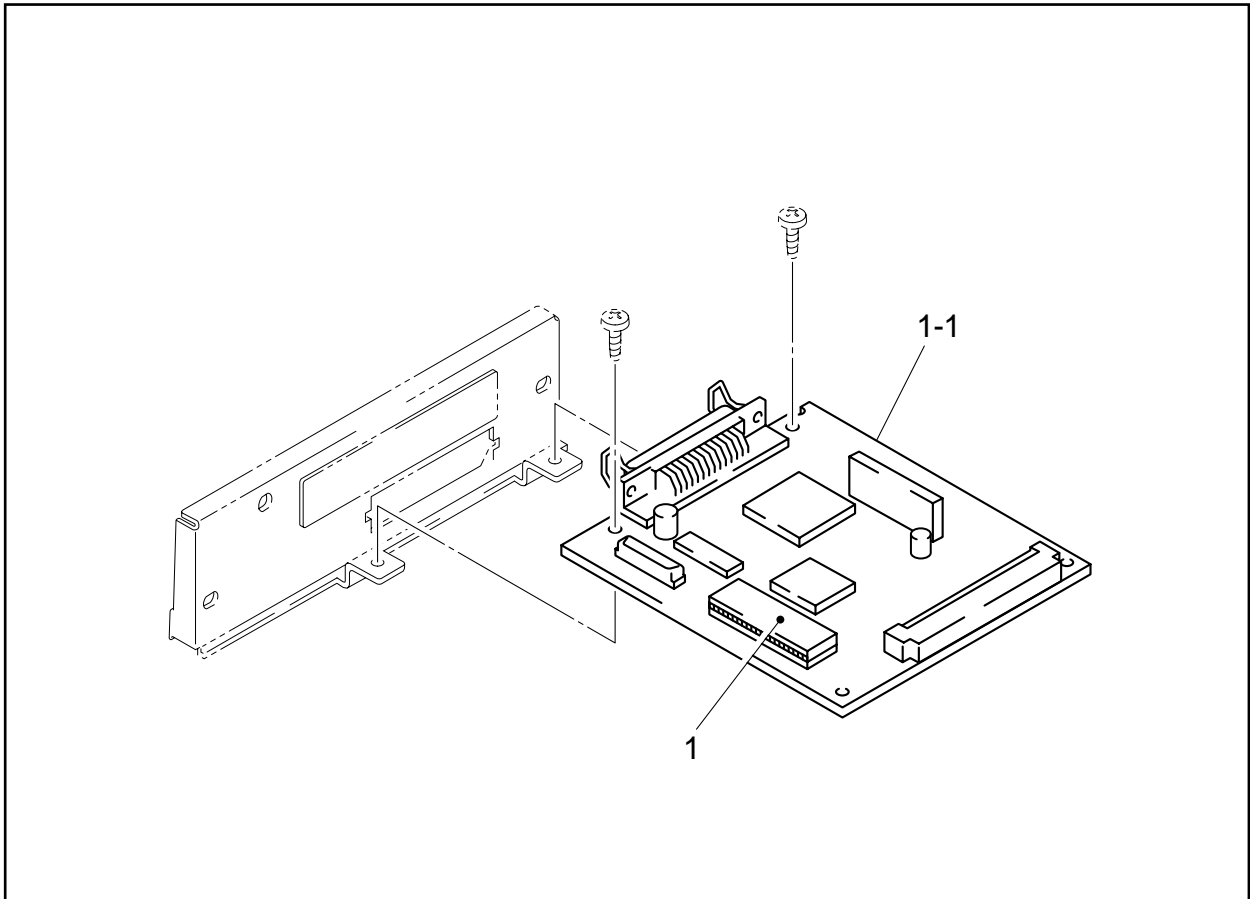

MODEL HL-1040 84U-831-101/103

6-4/5. MAIN PCB <HL-1050 OTHERS/ISRAEL>

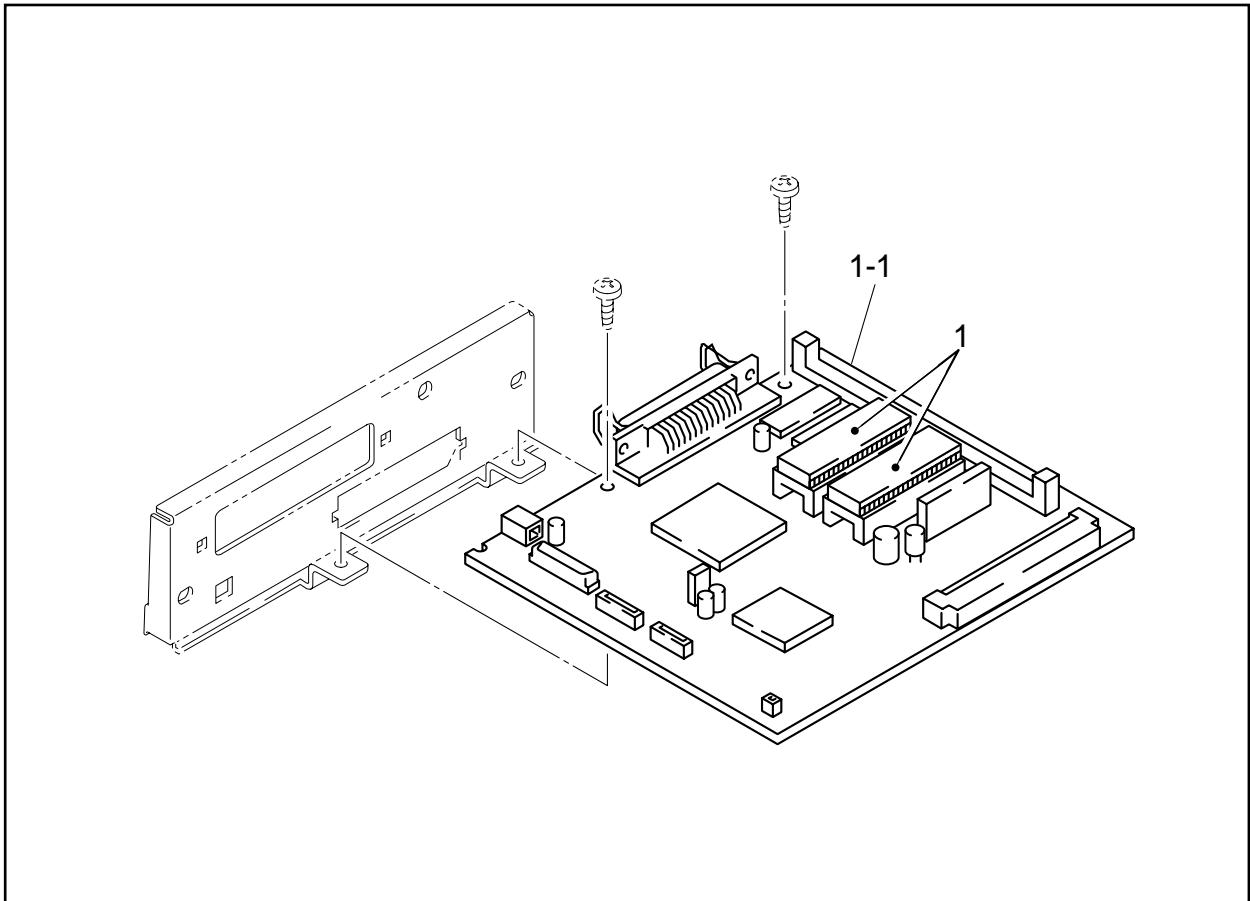

MODEL HL-1050 84U-861-101/103

POWER CORDS & PACKING DRAWING

10-	
1A	1F
1B	1G
1C	1H
1D	1I
1E	

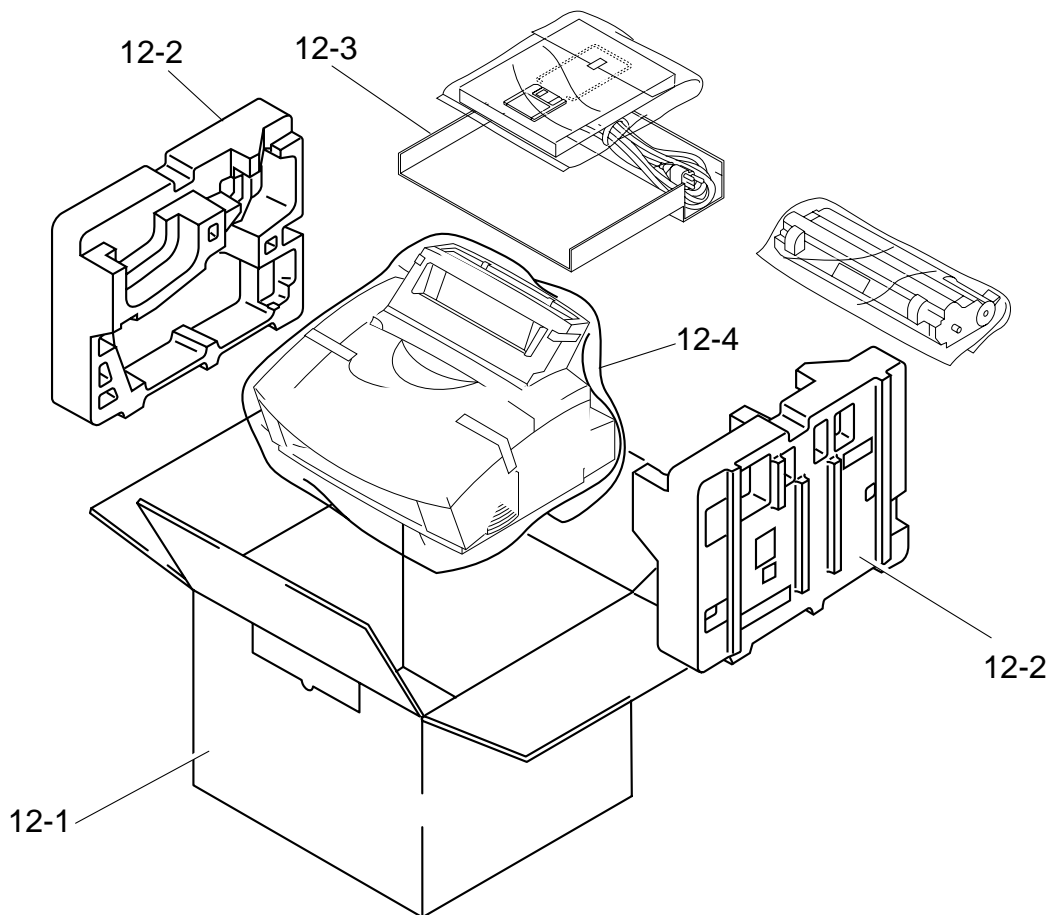

MODEL HL-820/1020/1040/1050 84U-821/831/861-230/930

1. DRIVE UNIT

REF.NO.	CODE	Q'TY	DESCRIPTION	REMARK
1	UL8747001	1	DRIVE UNIT ASSY (SP)	
2	087412016	3	TAPTITE, CUP B M4X20	
3	085411215	1	TAPTITE, BIND B M4X12	
4	UL7964001	1	MAIN MOTOR ASSY	
5	UL7968001	1	SUB MOTOR ASSY	
6	085320616	4	TAPTITE, BIND S M3X6	

MODEL HL-820/1020/1040/1050 84U-821/831/861-010

2. SCANNER UNIT

REF.NO.	CODE	Q'TY	DESCRIPTION	SYMBOL	REMARK
1	UL8748001	1	SCANNER UNIT Y (SP)	(B48K226)	
2	085411215	3	TAPTITE, BIND B M4X12		
3	UL8759001	1	TONER SENSOR PCB ASSY	B48K231	
4	087310815	1	TAPTITE, CUP B M3X8		
5	UH3064001	1	S SEAL SPONGE 4		

MODEL HL-820/1020/1040/1050 84U-821/831/861-020



3. MP SHEET FEEDER

REF.NO.	CODE	Q'TY	DESCRIPTION	REMARK
1	UL8749001	1	MP SHEET FEEDER ASSY (SP)	

MODEL HL-820/1020/1040/1050 84U-821/831/861-040

4. FIXING UNIT

REF.NO.	CODE	Q'TY	DESCRIPTION	REMARK
1-1	UL8750001	1	FIXING UNIT, 120V (SP)	
1-1	UL8751001	1	FIXING UNIT, 230V (SP)	
1	UH3306001	1	HALOGEN LAMP Y, 120V (SP)	
1	UH3307001	1	HALOGEN LAMP Y, 230V (SP)	
2	087411616	2	TAPTITE, CUP B M4X16	
3	085311216	2	TAPTITE, BIND B M3X12	
4	083311017	2	TAPTITE, PAN B M3X10	
5	UL8757001	1	HEAT ROLLER YS (SP)	
6	UH3178000	2	H/R BEARING Y	
7	UL8758001	1	H/R CLEANER	
8	UL8754001	1	H/R WASHER	

MODEL HL-820/1020/1040/1050 84U-821/831/861-050/051

T/I NO. PR98116

5. COVERS

REF.NO.	CODE	Q'TY	DESCRIPTION	SYMBOL	REMARK
1	UL7983001	1	MAIN COVER ASSY	B48K304	
2	085411215	1	TAPTITE, BIND B M4X12		
3	085411215	1	TAPTITE, BIND B M4X12		
4	085411215	1	TAPTITE, BIND B M4X12		
5	002400616	3	SCREW PAN M4X6		
6	087320616	2	TAPTITE, CUP S M3X6		
7	0A5350605	1	SCREW PAN(WASHER), M3.5X6		
8	UL8659001	1	EL PCB UNIT		
9	UL8753001	1	MAIN FAN MOTOR		
10	UL8509001	1	SUB FAN MOTOR		
11	085411215	2	TAPTITE, BIND B M4X12		
12	UL8505001	1	BASE PLATE 820/1020/1040		
12	UL8601001	1	BASE PLATE 1050		
13	UL8506001	1	MAIN PCB GUIDE RAIL (820/1020/1040)		
14	UL8507001	2	RUBBER FOOT		
15	085411215	8	TAPTITE, BIND B M4X12		
16	087320616	5	TAPTITE, CUP S M3X6		
17	UL8508001	1	INSULATION SHEET		
18	UL8512001	1	INLET HOLDER		
19	085411215	1	TAPTITE, BIND B M4X12		
20	UL8510001	1	I/F SHIELD ASSY 820/1020/1040		
20	UL8604001	1	I/F SHIELD ASSY 1050		
21	UL8518001	1	PANEL COVER, GRAY1227		
22	UL8745001	1	TOP COVER ASSY		
23	UL8515001	1	OUTPUT TRAY		
24	UL8516001	1	EXTENSION SUPPORT WIRE		
25	UL8746001	1	REAR COVER ASSY		
26	085411215	2	TAPTITE, BIND B M4X12		
27	UL6740001	1	LASER CAUTION LABEL		
28	UL6741001	1	TONER WARNING LABEL		
29	UL8575001	1	MODEL PLATE, HL-820		
29	UL8639001	1	MODEL PLATE, HL-1020		
29	UL8519001	1	MODEL PLATE, HL-1040		
29	UL8641001	1	MODEL PLATE, HL-1040DX		
29	UL8611001	1	MODEL PLATE, HL-1050		
29	UL8645001	1	MODEL PLATE, HL-1050DX		
29	UL8820001	1	MODEL PLATE, HL-1050 LEGEND		
30	UL8640001	1	MYLAR LABEL, HL-1020 CAN		
30	UL8650001	1	MYLAR LABEL, HL-820 EUR		
30	UL8522001	1	MYLAR LABEL, HL-1040 US		
30	UL8547001	1	MYLAR LABEL, HL-1040 CAN		
30	UL8642001	1	MYLAR LABEL, HL-1040DX CAN		
30	UL8651001	1	MYLAR LABEL, HL-1040 EUR		
30	UL8612001	1	MYLAR LABEL, HL-1050 US		
30	UL8596001	1	MYLAR LABEL, HL-1050 CAN		
30	UL8646001	1	MYLAR LABEL, HL-1050DX CAN		
30	UL8652001	1	MYLAR LABEL, HL-1050 EUR		
31	UH3297001	1	C-TICK MARK LABEL		
32	UH0905001	1	US PATENT SEAL HL-10		
33	UG3005000	4	FERRITE CORE		
34	UG3005000	7	FERRITE CORE (HL1050)		
35	UK3617000	1	CORE, TFC-16813 (HL1050)		

MODEL HL-820/1020/1040/1050 84U-821/831/861-060

T/I NO. PR98096 / PR98110

6-1. MAIN PCB <HL-820/1020>

REF.NO.	CODE	Q'TY	DESCRIPTION	SYMBOL	REMARK
1-1	UK4202001	1	MAIN PCB ASSY, HL-820 (SP)	B48K312-250B	
1-1	UK4229001	1	MAIN PCB ASSY, HL-1020 (SP)	B48K312-260B	
1	UK4003000	1	MROM HL1040	#3	

MODEL HL-820/1020 84U-821-101/104

6-2. MAIN PCB <HL-1040 OTHERS>

REF.NO.	CODE	Q'TY	DESCRIPTION	SYMBOL	REMARK
1-1	UK4200001	1	MAIN PCB ASSY, HL-1040 (SP)	B48K312-200C	
1	UK4003000	1	MROM HL1040	#3	

MODEL HL-1040 84U-831-101

6-3. MAIN PCB <HL-1040 ISRAEL>

REF.NO.	CODE	Q'TY	DESCRIPTION	SYMBOL	REMARK
1-1	UK4201001	1	MAIN PCB ASSY, HL-1040 HEB (SP)	B48K312-201	
1	UK3995000	1	MROM HL1040H	#3	

MODEL HL-1040 84U-831-103

6-4. MAIN PCB <HL-1050 OTHERS>

REF.NO.	CODE	Q'TY	DESCRIPTION	SYMBOL	REMARK
1-1	UK4203001	1	MAIN PCB ASSY, HL-1050 (SP)	B512001-200B	.
1	UK4045000	1	MROM1050-EVEN	#11	
2	UK4046000	1	MROM1050-ODD	#7	

MODEL HL-1050 84U-861-101

T/I NO. PR98109

6-5. MAIN PCB <HL-1050 ISRAEL>

REF.NO.	CODE	Q'TY	DESCRIPTION	SYMBOL	REMARK
1-1	UK4204001	1	MAIN PCB ASSY, HL-1050 (SP)	B512001-201A	
1	UK3998000	1	MROM1050H-EVEN	#11	
2	UK3999000	1	MROM1050H-ODD	#7	

MODEL HL-1050 84U-861-103

T/I NO. PR98109

7. PANEL SENSOR PCB

REF.NO.	CODE	Q'TY	DESCRIPTION	SYMBOL	REMARK
1	UK4205001	1	PANEL SENSOR PCB ASSY (SP)	B48K303	

MODEL HL-820/1020/1040/1050 84U-821/831/861-151

8. POWER SUPPLY PCB

REF.NO.	CODE	Q'TY	DESCRIPTION	REMARK
1	UK4118001	1	LOW-VOLTAGE PS ASSY, 115V HL-820/1020/1040 (SP)	REV. B
1	UK4120001	1	LOW-VOLTAGE PS ASSY, 115V HL-1050 (SP)	
1	UK4119001	1	LOW-VOLTAGE PS ASSY, 230V HL-820/1020/1040 (SP)	
1	UK4121001	1	LOW-VOLTAGE PS ASSY, 230V HL-1050 (SP)	
2	UK3836001	1	AC INLET ASSY, 115V	
2	UK3843001	1	AC INLET ASSY, 230V	

MODEL HL-820/1020/1040/1050 84U-821/831/861-200/201

T/I NO. PR98112

9. HIGH VOLTAGE POWER SUPPLY

REF.NO.	CODE	Q'TY	DESCRIPTION	REMARK
1	UK4122001	1	HIGH-VOLTAGE PS ASSY (SP)	

MODEL HL-820/1020/1040/1050 84U-821/831/861-220

10. AC CORDS

REF.NO.	CODE	Q'TY	DESCRIPTION	REMARK
1A	UH1051001	1	AC CORD ASSY, UL/CSA	
1B	UH1054001	1	AC CORD ASSY, BS	
1C	UH1052001	1	AC CORD ASSY, VDE	
1D	UH1055001	1	AC CORD ASSY, SAA	
1E	UH1053001	1	AC CORD ASSY, SEV	
1F	UK4094001	1	AC CORD ASSY, DEMKO	
1G	U34320001	1	AC CORD ASSY, #4 (SAF)	
1H	UK4099001	1	AC CORD ASSY, CHLI	
1I	U34322001	1	AC CORD ASSY, #6 (ISRAEL)	

MODEL HL-820/1020/1040/1050 84U-821/831/861-230

## 11. ACCESSORIES

REF.NO.	CODE	Q'TY	DESCRIPTION	REMARK
1	UK4090001	1	PR DRIVER DISK ASSY1, 820 (WINDOWS)	
1	UK4193001	1	PR DRIVER DISK ASSY1, 1020 (WINDOWS)	
1	UK3875001	1	PR DRIVER DISK ASSY1, 1040 (WINDOWS)	
1	UK3895001	1	PR DRIVER DISK ASSY1, 1050 (WINDOWS)	
1	UK4179001	1	PR DRIVER DISK ASSY 1, 1050HEB(WINDOWS)	
1	UK4233001	1	PR DRIVER DISK ASSY 1, 1050LEG(WINDOWS)	
2	UK4092001	1	PR DRIVER DISK ASSY2, 820 (TRUETYPE)	
2	UK4195001	1	PR DRIVER DISK ASSY2, 1020 (TRUETYPE)	
2	UK3877001	1	PR DRIVER DISK ASSY2, 1040 (TRUETYPE)	
2	UK3897001	1	PR DRIVER DISK ASSY2, 1050 (TRUETYPE)	
2	UK4181001	1	PR DRIVER DISK ASSY2, 1050HEB(TRUETYPE)	
2	UK4235001	1	PR DRIVER DISK ASSY2, 1050LEG(TRUETYPE)	
3	UK4197001	1	PR DRIVER DISK ASSY6, 1050 ARABIC	
4	UK4199001	1	CD-ROM ASSY	
5	UL6856000	1	PAPER SUPPORT	
6	UL8529001	1	SET GUIDE, US	
6	UL8550001	1	SET GUIDE, FRA	
6	UL8534001	1	SET GUIDE, GER	
6	UL8557001	1	SET GUIDE, NOR	
6	UL8560001	1	SET GUIDE, NL	
6	UL8565001	1	SET GUIDE, DEN	
6	UL8568001	1	SET GUIDE, ITA	
6	UL8571001	1	SET GUIDE, SWE	
6	UL8739001	1	SET GUIDE, SPA	
7	UE2014001	1	BAG, 215X350H	
8	UK4156001	1	CORE NF-13 ASSY (HL1050)	

MODEL HL-820/1020/1040/1050 84U-821/831/861-920

T/I NO. PR98100 / PR98110

12. PACKING MATERIALS

REF.NO.	CODE	Q'TY	DESCRIPTION	REMARK
1	UE2233001	1	CARTON, EUR HL-820	
1	UE2236001	1	CARTON, CAN HL-1020	
1	UE2239001	1	CARTON, USA HL-1040	
1	UE2240001	1	CARTON, CAN HL-1040	
1	UE2222001	1	CARTON, EUR HL-1040	
1	UE2237001	1	CARTON, CAN HL-1040DX	
1	UE2241001	1	CARTON, USA HL-1050	
1	UE2230001	1	CARTON, EUR HL-1050	
1	UE2238001	1	CARTON, CAN HL-1050DX	
1	UE2242001	1	CARTON, CAN HL-1050	
1	UE2248001	1	CARTON, LEGEND HL-1050	
2	UE2223001	1	STYROFOAM PAD ASSY	
3	UE2226001	1	CARTON, ACCESORRIES	
4	UE2126001	1	BAG, 700X800 (BODY)	

MODEL HL-820/1020/1040/1050 84U-821/831/861-930

T/I NO. PR98087 / PR98110