



---

***DF-71***

**PARTS LIST**

Published in Aug.'01  
843CG120

## NOTE

1. Indicate parts number and machine model when placing an order.

eg.	Parts Number	Parts Name	Machine Model	Cycle	Quantity
	3C104011	FRONT COVER	DF-71	50Hz	1

2. Service calls and freight will be charged separately.

3. Symbols in the "Parts Number" column.

- Parts with "●" indicates the service parts and the parts without "●" can not be supplied.
- Parts with "•" are component parts or sub-assemblies of the assembly appearing immediately above them.

eg.	Parts Number	Parts Name	Parts Number	Parts Name
	3AK27510	WIRE, MIDDLE TRAY	•J0150900	CONTACTOR, 175161-1(AMP)
			•J0250900	SOCKET, BHF-001T-0.8SS

4. See the last page of this parts list for the classification of the screws in the illustrations.

5. Items indicated by shaded areas (  ) are supply parts and should be ordered through your Regional Office.

———— CONTENTS ————

FIG. 1	EXTERIOR COVERS .....	2
FIG. 2	FRAMES .....	4
FIG. 3	BIN SECTION .....	6
FIG. 4	PAPER CONVEYING SECTION I .....	8
FIG. 5	PAPER CONVEYING SECTION II (Inch) .....	10
FIG. 5	PAPER CONVEYING SECTION II (Metric) .....	12
FIG. 6	MIDDLE TRAY I .....	14
FIG. 7	MIDDLE TRAY II .....	16
FIG. 8	DRIVING SECTION I .....	18
FIG. 9	DRIVING SECTION II .....	22
FIG. 10	ELECTRICAL COMPONENTS I .....	24
FIG. 11	ELECTRICAL COMPONENTS II .....	26
FIG. 12	DECURLER .....	28
FIG. 13	ACCESSORIES & OPTION I .....	30
FIG. 14	OPTION II .....	32
	• INDEX .....	34

FIG. 1 EXTERIOR COVERS

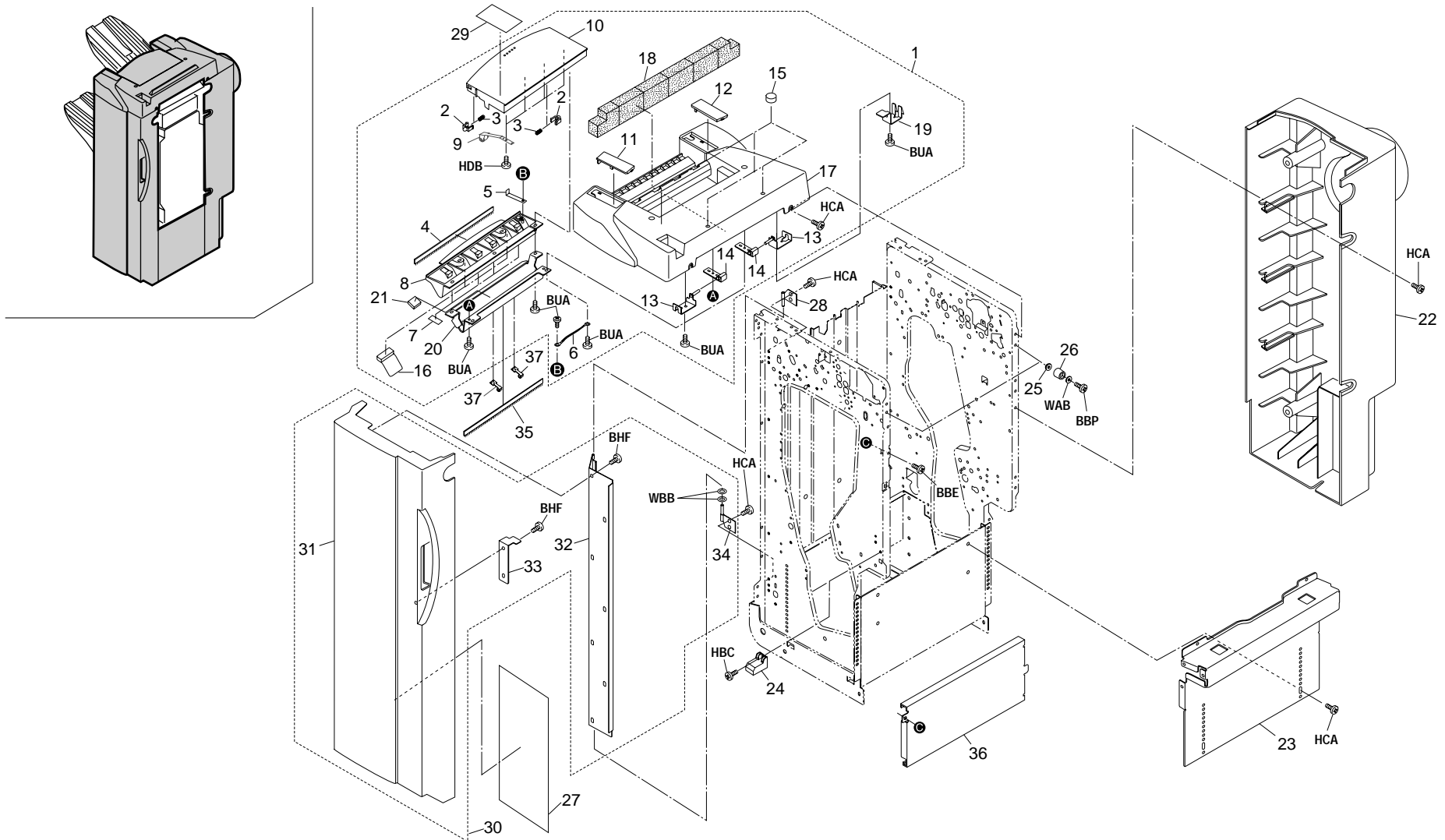

FIG. 1 EXTERIOR COVERS

3CG

SP	Ref. No.	Part. No.	Description	Quantity		
				120V	230V	240V
	1	3CD00030	TOP COVER ASS'Y	1	1	1
	2	•33906880	STOPPER,BYPASS TABLE	2	2	2
	3	•65926530	SPRING,SAFETY SWITCH	2	2	2
●	4	•63212210	STATIC ELIMINATOR,EJECT	1	1	1
	5	•3AK16270	PLATE SPRING,EJECT GROUND	1	1	1
	6	•63527200	GROUND WIRE,STATIC ELIMINATOR	1	1	1
	7	•3AK16261	SHEET,EJECT	4	4	4
	8	•3AK16220	GUIDE,EJECT	1	1	1
	9	•3AK00220	EJECT PULLEY ASS'Y	4	4	4
●	10	•3AK04540	TOP COVER,RELEASE(KM)	1	1	1
●	11	•3AK04570	FRONT LID, TOP COVER(KM)	1	1	1
●	12	•3AK04580	REAR LID, TOP COVER(KM)	1	1	1
	13	•3C104040	FULCRUM PLATE, TOP COVER	2	2	2
●	14	•3C104100	TOP HINGE,COVER	2	2	2
●	15	•3AK05510	TOP LABEL,COVER(KM)	4	4	4
	16	•3BD04050	TOP SHEET,RELEASE	2	2	2
●	17	•3C104030	TOP COVER	1	1	1
●	18	•3BD04030	TOP VIBRATION INSULATOR B,COVER	1	1	1
	19	•3C104050	TOP GROUND PLATE,COVER	1	1	1
	20	•3C116040	UPPER GUIDE,CONVEYING	1	1	1
	21	•78710370	CUSHION UPPER LOOP	1	1	1
●	22	3C104020	REAR COVER	1	1	1
	23	3C104060	RIGHT COVER	1	1	1
	24	3AK04160	GUIDE,FRONT COVER	1	1	1
	25	18314060	COLLAR,PARTITION JOINT	2	2	2
	26	75402210	CUSHION STAY	2	2	2
●	27	3C105020	LABEL,JAM REMOVENT	1	1	1
	28	3AK04110	UPPER FULCRUM PLATE,FRONT COVER	1	1	1
●	29	3CG05070	LABEL,OPERATION PAPER SET(USA)	1		
●	29	3CG05080	LABEL,OPERATION PAPER SET(EUR)		1	1
	30	3C100181	FRONT COVER ASS'Y	1	1	1
●	31	•3C104011	FRONT COVER	1	1	1
	32	•3AK04100	FRONT HINGE,COVER	1	1	1
	33	•3AK04150	FRONT BASE,MAGNET	1	1	1
●	34	•3AK04120	UNDER FULCRUM PLATE,FRONT COVER	1	1	1
●	35	73920270	STATIC ELIMINATOR,FIXING UNIT	1	1	1
	36	3C102090	REINFORCEMENT,FINISHER SORTER	1	1	1
●	37	3AK68030	UPPER CONVEYING PULLEY ASS'Y	2	2	2

- Parts with "•" are component parts or sub-assemblies of the assembly appearing immediately above them.
- Parts with "●" indicates the Service parts.



FIG. 2 FRAMES

3CG

SP	Ref. No.	Part. No.	Description	Quantity		
				120V	230V	240V
	1	3C100010	BASE ASS'Y	1	1	1
	2	*3AK02220	SHAFT,BASE PULLEY	2	2	2
	3	*3AK02080	PULLEY,FINISHER	2	2	2
	4	*3C102070	SLIDER,FINISHER	2	2	2
	5	*3BD02042	MOUNT,SLIDER	1	1	1
	6	*3BD02050	MOVING PLATE,PULLEY SORTER	1	1	1
	7	*3AK02240	PULLEY,SORTER	1	1	1
	8	*3AK02250	SHAFT,CONVEYING SUPPORT PLATE	1	1	1
	9	*3BD02060	SHAFT,CASTER	1	1	1
	10	*3AK02041	BASE,FINISHER	1	1	1
	11	*3BD04010	RIGHT VIBRATION INSULATOR,BASE	1	1	1
	12	3AK02160	HOOK,FINISHER RELEASE	2	2	2
	13	3AK02210	PLATE SPRING,HOOK RELEASE	2	2	2
	14	3C102040	STAY,FEED IN	1	1	1
	15	3AK02170	WORK PLATE,HOOK RELEASE	1	1	1
	16	3AK02101	REINFORCEMENT,REAR COVER	1	1	1
	17	3AK07300	RETAINER,MIDDLE TRAY	1	1	1
	18	48128807	PIN,FRAME	2	2	2
	19	29407191	TENSION SPRING,PF	1	1	1
	20	48128609	PIN,UPPER FRONT COVER	1	1	1
●	21	3AK05030	LABEL,PUNCH DISPOSAL	1	1	1
	22	3C112040	GUIDE,DISPOSAL TANK	1	1	1
	23	3AK12340	MOUNT,DISPOSAL TANK	2	2	2
●	24	18327140	SWITCH,PARTITION	1	1	1
●	25	3AK00310	DISPOSAL TANK ASS'Y	1	1	1
	26	*3AK12330	TANK,DISPOSAL	1	1	1
	27	*74306880	RATCH,PAPER GUIDE	2	2	2
	28	3C100200	RELEASE LEVER ASS'Y	1	1	1
	29	*48127502	PIN,SEPARATION PULLEY	1	1	1
	30	*36802270	REINFORCEMENT,RELEASE LEVER	1	1	1
	31	*3C104090	LEVER,RELEASE	1	1	1
	32	*3AK02130	MOUNT,RELEASE LEVER	1	1	1
	33	*3AK02180	JUNCTION PLATE,RELEASE LEVER	1	1	1
	34	*48128609	PIN,UPPER FRONT COVER	1	1	1
	35	3C100020	FRONT FRAME ASS'Y	1	1	1
	36	*3C102010	FRONT FRAME	1	1	1
	37	*3AK20010	RAIL,MAIN TRAY	1	1	1
	38	3C100030	REAR FRAME ASS'Y	1	1	1
	39	*3C102020	REAR FRAME	1	1	1
	40	*3AK20010	RAIL,MAIN TRAY	1	1	1

SP	Ref. No.	Part. No.	Description	Quantity		
				120V	230V	240V
	41	*3C102030	PARTITION,FINISHER	1	1	1
	42	3AK02140	GUIDE,FINISHER RELEASE	2	2	2
	43	M2109230	WIRE SADDLE,LWS-3S(KITAGAWA)	2	2	2
	44	3AK02230	SPONGE,BASE	2	2	2
	45	M1203220	OPEN BUSHING,OCB-625	1	1	1
	46	M1203510	OPEN BUSHING,OCB-1000	1	1	1
	47	3AK02060	STAY,PARTITION	2	2	2
	48	3AK07350	SLIDER,MIDDLE	2	2	2
	49	3AK02070	STAY,MIDDLE TRAY	1	1	1
	50	M2109260	WIRE SADDLE,YMC-05-H-0(KITAGAWA)	1	1	1
	51	M2104200	EDGING EDS-1	1	1	1
	52	3AK02150	SHAFT,HOOK RELEASE	1	1	1

- Parts with "●" are component parts or sub-assemblies of the assembly appearing immediately above them.
- Parts with "●" indicates the Service parts.

FIG. 3 BIN SECTION

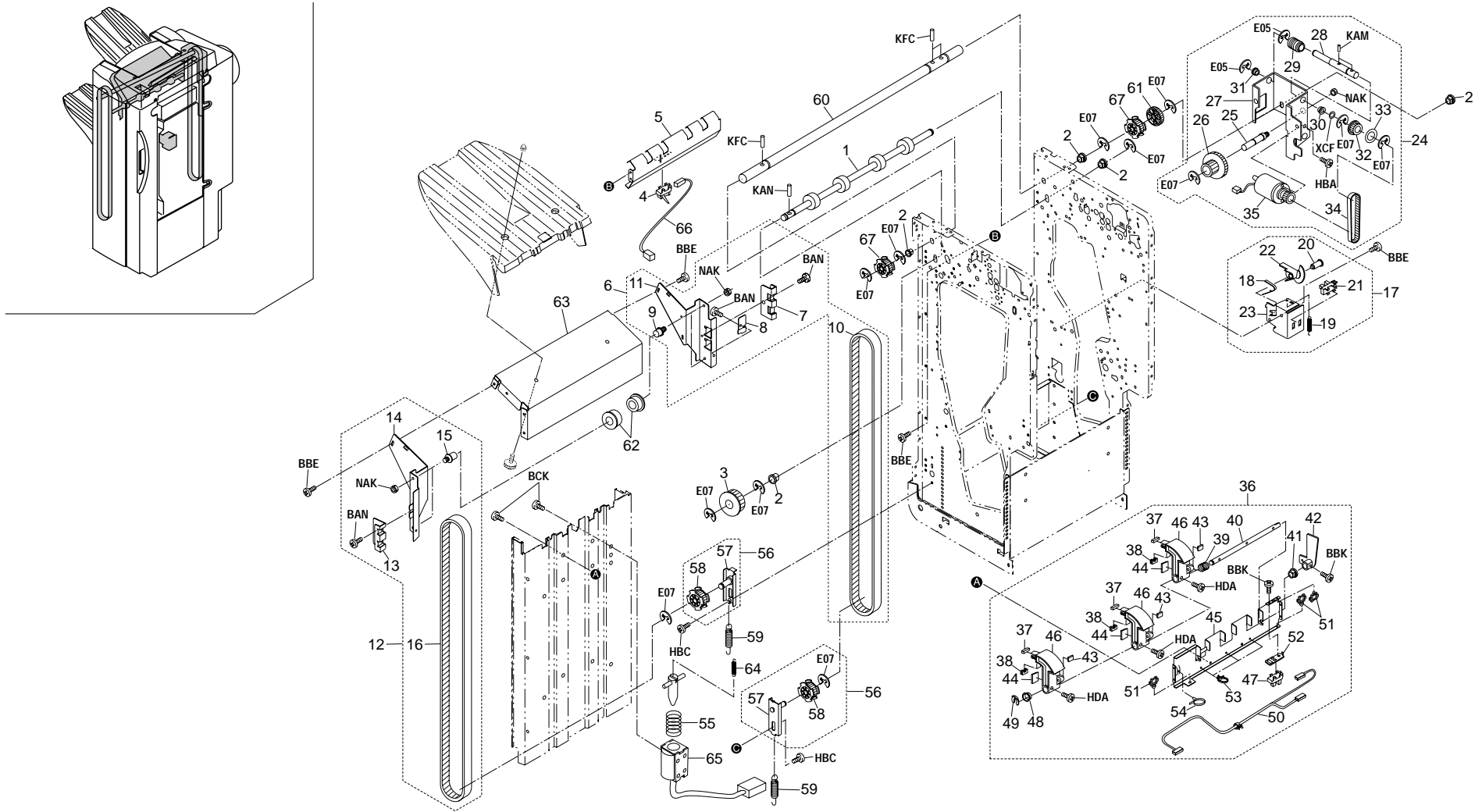



FIG. 3 BIN SECTION

3CG

SP	Ref. No.	Part. No.	Description	Quantity		
				120V	230V	240V
●	1	3AK06010	ROLLER,EJECT MAIN	1	1	1
	2	49021100	BUSHING	5	5	5
●	3	3C106100	PULLEY 28, SORT EJECT	1	1	1
●	4	34827020	SWITCH,REGISTRATION	1	1	1
	5	3C106080	LOWER GUIDE,MAIN EJECT	1	1	1
	6	3AK00160	REAR FRAME MAIN TRAY ASS'Y	1	1	1
	7	•3AK20050	HOLDER,TIMING BELT	1	1	1
	8	•3AK20140	DETECTION PLATE,MAIN TRAY	1	1	1
	9	•3AK20180	PIN,MAIN TRAY	2	2	2
●	10	•3AK20210	BELT,TRAY LIFT	1	1	1
	11	•3AK20030	REAR FRAME,MAIN TRAY	1	1	1
	12	3AK00150	FRONT FRAME MAIN TRAY ASS'Y	1	1	1
	13	•3AK20050	HOLDER,TIMING BELT	1	1	1
	14	•3AK20020	FRONT FRAME,MAIN TRAY	1	1	1
	15	•3AK20180	PIN,MAIN TRAY	2	2	2
●	16	•3AK20210	BELT,TRAY LIFT	1	1	1
	17	3AK00210	MAIN MIDDLE SW ASS'Y	1	1	1
	18	•3AK20170	FILM,MAIN TRAY SENSOR	1	1	1
	19	•3AK20250	SPRING,MAIN TRAY SENSOR MIDDLE	1	1	1
	20	•29802230	PIN,CONNECTOR	1	1	1
●	21	•35327400	SWITCH,FEED	1	1	1
	22	•3AK20150	DETECTION PLATE,MAIN TRAY SENSOR MIDDLE	1	1	1
	23	•3AK20160	MOUNT,MAIN TRAY SENSOR MIDDLE	1	1	1
	24	3AK00180	MAIN TRAY DRIVE ASS'Y	1	1	1
	25	•3AK20120	SHAFT 18/50	1	1	1
●	26	•3AK20080	GEAR 18/50	1	1	1
	27	•3AK20100	MOUNT,MAIN TRAY DRIVE	1	1	1
	28	•3AK20110	SHAFT,WORM	1	1	1
●	29	•3AK20130	GEAR,WORM MAIN TRAY	1	1	1
	30	•49028101	BUSH 8	1	1	1
●	31	•74808080	BEARING,686ZZNR	1	1	1
●	32	•63416200	PULLEY 34,CONVEYING	1	1	1
	33	•78918290	FLANGE PULLEY 27	1	1	1
●	34	•3AK20220	BELT,TRAY DRIVE	1	1	1
●	35	•3AK27010	MOTOR,MAIN TRAY	1	1	1
	36	3C100120	HOLDER MAIN EJECT ASS'Y	1	1	1
●	37	•63213261	PAD, EJECT ORIGINAL HOLDER	6	6	6
	38	•63213300	RETAINER,EJECT ORIGINAL HOLDER	6	6	6
	39	•3C106070	SPRING,HOLDER MAIN EJECT RESET	1	1	1
	40	•3C106050	SHAFT,HOLDER MAIN EJECT	1	1	1

SP	Ref. No.	Part. No.	Description	Quantity		
				120V	230V	240V
	41	•73210450	BUSH, 6	1	1	1
	42	•3C106040	LEVER,HOLDER MAIN EJECT	1	1	1
	43	•63213320	CUSHION,ORIGINAL COLLECTION	3	3	3
	44	•3AK08480	CUSHION,FEED SHIFT GUIDE	3	3	3
	45	•3C106030	STAY,MAIN EJECT	1	1	1
	46	•3C106010	HOLDER,MAIN EJECT	3	3	3
●	47	•35327400	SWITCH,FEED	1	1	1
●	48	•76514080	BUSHING 6 DRIVE	1	1	1
●	49	•34806140	STOPPER 4	1	1	1
	50	•3C127550	JUNCTION WIRING,EJECT SOLENOID	1	1	1
	51	•M2105740	MINIATURE CLAMP,UAMS-05S-2	3	3	3
	52	•3C106020	MOUNT,MAIN EJECT PI	1	1	1
	53	•M2107120	BINDING BAND SG-130	3	3	3
	54	•M0207000	BINDING BAND,KB-100-1	1	1	1
	55	3C108290	SPRING,TURN SOLENOID	1	1	1
	56	3AK00170	TENSION PLATE MAIN TRAY ASS'Y	2	2	2
	57	•3AK20060	TENSION PLATE,MAIN TRAY	2	2	2
●	58	•3AK20230	PULLEY 20S5M	2	2	2
	59	19020050	SPRING,PRESSURE	2	2	2
	60	3AK20070	SHAFT,MAIN TRAY DRIVE	1	1	1
●	61	3AK20090	GEAR 51	1	1	1
	62	3AK20200	PULLEY,MAIN TRAY	4	4	4
	63	3AK20040	SUPPORT PLATE,MAIN TRAY	1	1	1
	64	3C106061	SPRING,HOLDER MAIN EJECT PULL	1	1	1
●	65	3C127010	SOLENOID,EJECT	1	1	1
	66	3C127540	JUNCTION WIRING,EJECT SENSOR	1	1	1
●	67	3AK20230	PULLEY 20S5M	2	2	2

- Parts with "•" are component parts or sub-assemblies of the assembly appearing immediately above them.
- Parts with "●" indicates the Service parts.

FIG. 4 PAPER CONVEYING SECTION I

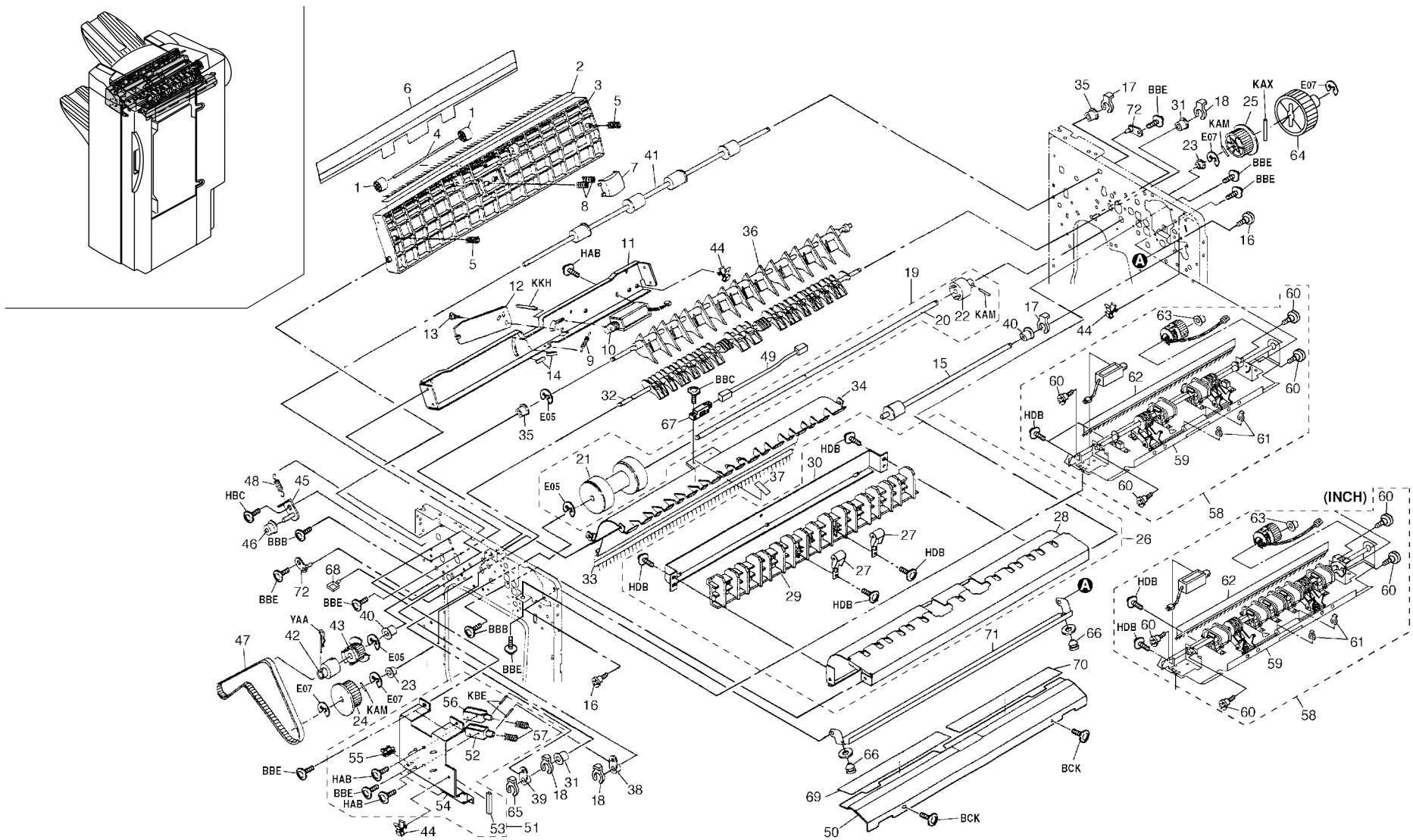

FIG. 4 PAPER CONVEYING SECTION I

3CG

SP	Ref. No.	Part. No.	Description	Quantity		
				120V	230V	240V
●	1	62221110	PULLEY,FEEDBACK	2	2	2
●	2	63212210	STATIC ELIMINATOR,EJECT	1	1	1
	3	3AK06020	UPPER GUIDE,MAIN EJECT	1	1	1
	4	3AK06040	SHAFT,MAIN EJECT PULLEY	1	1	1
	5	3AK06120	SPRING,MAIN EJECT	2	2	2
	6	3C106110	FILM,MAIN EJECT(INCH)	1		
	6	3C106120	FILM,MAIN EJECT(METRIC)		1	1
	7	3AK06180	HOLDER,MAIN EJECT PRESSURE	1	1	1
	8	3BD06040	SPRING B,MAIN EJECT PRESSURE	2	2	2
	9	33420250	SPRING,FIXING CLAW	1	1	1
●	10	62227070	SOLENOID B,FEED SHIFT	1	1	1
	11	3AK06160	MOUNT,MAIN EJECT PRESSURE	1	1	1
	12	3AK06172	TURN PLATE,MAIN EJECT PRESSURE	1	1	1
	13	48127502	PIN,SEPARATION PULLEY	1	1	1
	14	63213320	CUSHION,ORIGINAL COLLECTION	2	2	2
●	15	3BD68020	ROLLER FEED IN ASS'Y SP	1	1	1
	16	29820420	PIN,BEARING	2	2	2
●	17	34806150	STOPPER 5	2	2	2
●	18	34806140	STOPPER 4	3	3	3
	19	3C100160	CONVEYING PULLEY ASS'Y	1	1	1
	20	●3C122040	SHAFT,CONVEYING PULLEY	1	1	1
●	21	●3AK16030	PULLEY,CONVEYING	1	1	1
●	22	●3AK16240	TORQUE LIMITER,MIDDLE DRIVE	1	1	1
●	23	67322230	BUSHING 8	2	2	2
●	24	3AK22040	PULLEY 40,FEED IN	1	1	1
●	25	3BD22040	PULLEY 31,CONVEYING ROLLER	1	1	1
	26	3C100231	LOWER GUIDE CONVEYING ASS'Y	1	1	1
●	27	●3AK68040	LOWER CONVEYING PULLEY ASS'Y	2	2	2
	28	●3C116050	LOWER GUIDE,CONVEYING	1	1	1
	29	●3AK16101	GUIDE,CONVEYING	1	1	1
	30	●3AK16251	REINFORCEMENT,CONVEYING GUIDE	1	1	1
	31	72914140	REAR BUSHING,TONER RECYCLE	2	2	2
	32	3AK16120	LOWER CLAW,CONVEYING	1	1	1
●	33	75416230	STATIC ELIMINATOR SORT BIN	1	1	1
	34	3C116150	LEFT GUIDE,CONVEYING	1	1	1
●	35	29806560	BUSHING 6	2	2	2
	36	3AK16110	UPPER SEPARATION CLAW,CONVEYING	1	1	1
	37	3AK05080	LABEL,TRAILING EDGE STANDARD		1	1
	38	3AK16130	UPPER LEVER,CONVEYING	1	1	1
	39	3AK16140	LOWER LEVER,CONVEYING	1	1	1

SP	Ref. No.	Part. No.	Description	Quantity		
				120V	230V	240V
	40	73210450	BUSH, 6	2	2	2
●	41	3AK16010	ROLLER,EJECT SUB	1	1	1
●	42	33906070	TORQUE LIMITER,PAPER FEED	1	1	1
●	43	3AK08230	PULLEY 20,COUPLING	1	1	1
	44	M2109260	WIRE SADDLE, YMC-05-H-0(KITAGAWA)	3	3	3
	45	3C106090	TENSION PLATE,LEADING REGISTRATION	1	1	1
●	46	48928800	PULLEY,TIMING BELT	1	1	1
●	47	3BD22180	BELT,EJECT DRIVE	1	1	1
	48	48529303	SPRING,TENSION	1	1	1
	49	3C127570	UPPER JUNCTION WIRING,CONVEYING SENSOR	1	1	1
	50	3C116080	LOWER GUIDE,FEED IN	1	1	1
	51	3C100250	CONVEYING SOLENOID ASS'Y	1	1	1
●	52	●62227070	SOLENOID B,FEED SHIFT	1	1	1
	53	●M2104100	EDGING CE-012	1	1	1
	54	●3AK16150	MOUNT,CONVEYING SOLENOID	1	1	1
	55	●M2104350	EDGING,EDS-0607M(KITAGAWA)	1	1	1
●	56	●18327130	SOLENOID,STOPPER	1	1	1
	57	●73226040	SPRING,REVERSE SOLENOID	2	2	2
●	58	3C100040	PUNCH ASS'Y(METRIC)		1	1
●	58	3C100050	PUNCH ASS'Y(INCH)	1		
	59	●3C112010	UNIT,PUNCH(METRIC)		1	1
	59	●3C112020	UNIT,PUNCH(INCH)	1		
	60	●60116080	PIN RAIL DEV.	4	4	4
●	61	●65016080	STOP RING E3	2	2	2
●	62	●66220160	STATIC ELIMINATOR,PRESSURE ROLLER	1	1	1
●	63	●G3163800	BEARING 63800ZZNRMC3	1	1	1
●	64	67322050	GEAR 45 DEVELOPING DRIVE	1	1	1
●	65	65016080	STOP RING E3	1	1	1
	66	73202040	RUBBER,SPACER	2	2	2
●	67	63227150	SWITCH L,FEED	1	1	1
	68	M2109230	WIRE SADDLE,LWS-3S(KITAGAWA)	1	1	1
●	69	3BD16050	LEFT SHEET A,FEED IN	1	1	1
●	70	3BD16060	LEFT SHEET B,FEED IN	1	1	1
	71	3C116070	UPPER GUIDE,FEED IN	1	1	1
	72	63202120	SUPPORT PLATE,COVER	2	2	2

- Parts with "●" are component parts or sub-assemblies of the assembly appearing immediately above them.
- Parts with "●" indicates the Service parts.

FIG. 5 PAPER CONVEYING SECTION II (Inch)

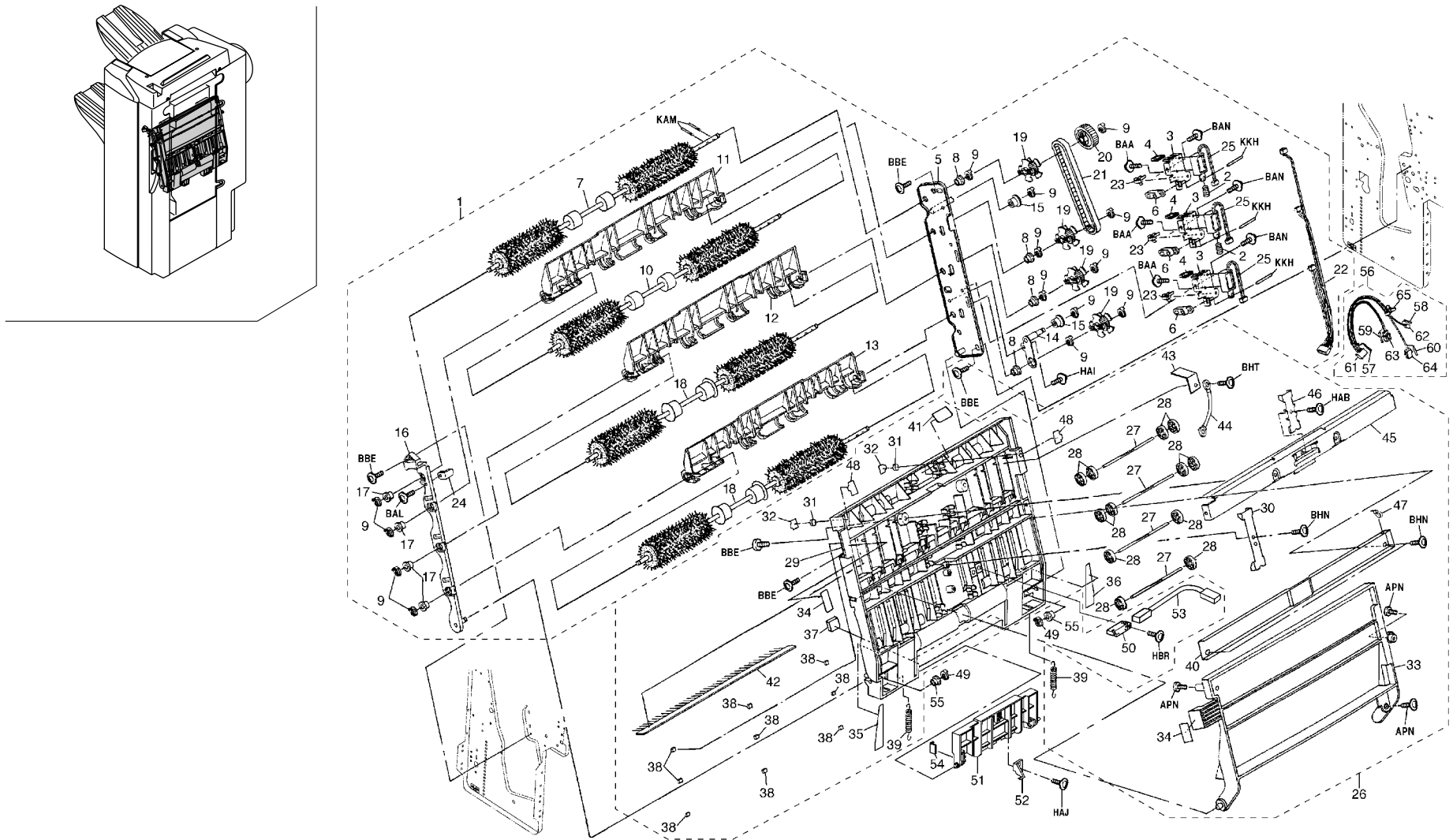

FIG. 5 PAPER CONVEYING SECTION II (Inch)

3CG

SP	Ref. No.	Part. No.	Description	Quantity USA(120V)
	1	3C100110	FEED SHIFT UNIT ASS'Y(INCH)	1
	2	•73226040	SPRING,REVERSE SOLENOID	2
	3	•3AK08201	MOUNT,FEED SHIFT SOLENOID	3
	4	•M2104200	EDGING EDS-1	3
	5	•3AK08090	REAR FRAME,FEED SHIFT(INCH)	1
	6	•3BD08060	LEVER,FEED SHIFT SOLENOID	3
●	7	•3C108040	ROLLER B1,FEED SHIFT	1
	8	•29806810	BUSHING,6 REGISTRATION	4
●	9	•34806150	STOPPER 5	13
●	10	•3BD08040	ROLLER B,FEED SHIFT	1
	11	•3C108070	GUIDE 17,FEED SHIFT	1
	12	•3C108060	GUIDE 14,FEED SHIFT	1
	13	•3C108050	GUIDE 11,FEED SHIFT	1
	14	•3AK08210	TENSION PLATE,FEED SHIFT	1
●	15	•48928800	PULLEY,TIMING BELT	1
	16	•3AK08081	FRONT FRAME,FEED SHIFT(INCH)	1
●	17	•29806560	BUSHING 6	4
●	18	•3C108030	ROLLER A1,FEED SHIFT	2
●	19	•3AK08230	PULLEY 20,COUPLING	4
●	20	•3BD22250	GEAR 17,FEED SHIFT ROLLER	1
●	21	•3AK08330	UPPER BELT,FEED SHIFT(INCH)	1
	22	•3AK27540	JUNCTION WIRING,PADDLE SOLENOID	1
	23	•M2107120	BINDING BAND SG-130	3
	24	•3AK08390	BASE,MAGNET FEED SHIFT	1
●	25	•3AK27040	SOLENOID,PADDLE	3
	26	3C100091	UPPER GUIDE FEED SHIFT ASS'Y(INCH)	1
	27	•3AK08150	UPPER SHAFT,FEED SHIFT	4
●	28	•3BD08050	PULLEY,FEED SHIFT	12
	29	•3C108010	UPPER GUIDE,FEED SHIFT(INCH)	1
	30	•3AK08130	PLATE SPRING,FEED SHIFT PULLEY(INCH)	1
	31	•3AK08371	MAGNET,FEED SHIFT	2
	32	•3AK08420	SEAL,MAGNET FEED SHIFT	2
	33	•3AK08183	GUIDE,FEED SHIFT SUB	1
	34	•3AK05050	LABEL,FEED SHIFT GUIDE	2
	35	•3AK08490	FRONT FILM,PAPER EDGE GUIDE	1
	36	•3AK08500	REAR FILM,PAPER EDGE GUIDE	1
	37	•3C108300	UPPER CUSHION,TURN	2
	38	•3AK08480	CUSHION,FEED SHIFT GUIDE	9
	39	•75914020	RELEASE SPRING MAIN DEVELOPING UNIT	2
	40	•3BD08070	LOWER REINFORCEMENT,FEED SHIFT GUIDE	1

SP	Ref. No.	Part. No.	Description	Quantity USA(120V)
	41	•3AK08560	FILM,PLATE SPRING GUIDE FILM	1
●	42	•18393020	PARTS,STATIC ELIMINATOR EJECT(SP)	1
	43	•3AK08451	PLATE SPRING,GROUND WIRE FEED SHIFT	1
	44	•63568070	GROUND WIRE,FEED ROLLER	1
	45	•3AK08170	REINFORCEMENT,FEED SHIFT GUIDE	1
	46	•3AK08160	PLATE SPRING,FEED SHIFT PULLEY	1
	47	•M2607010	BINDING BAND,PLT1M	1
	48	•3AK08570	LID,MAGNET	2
●	49	34806150	STOPPER 5	2
●	50	63227150	SWITCH L,FEED	1
	51	3C108210	UPPER TURN PLATE	1
	52	3C108220	STOPPER,TURN	1
	53	3C127560	LOWER JUNCTION WIRING,CONVEYING SENSOR	1
	54	3AK08430	SPACER,TURN	1
●	55	76514080	BUSHING 6 DRIVE	2
	56	3AK27560	JUNCTION WIRING,PAPER REGISTRATION SOLEN	1
	57	•J0452900	PIN,DF3-EP2428PC(HIROSE)	7
	58	•J0450900	SOCKET,DF3-2428SC(HIROSE)	2
	59	•J0242900	PIN SM,BYP-001T-0.6	3
	60	•J0250900	SOCKET,BHF-001T-0.8SS	2
	61	•J0453070	PRUG,DF3-7EP-2C(HIROSE)	1
	62	•J0450020	PLUG,DF3-2S-2C(HIROSE)	1
	63	•J0243030	RECEPTACLE SM 3P,SMR-03V-B	1
	64	•J0241020	PLUG SM 2P,SMP-02V-BC	1
	65	•M2607010	BINDING BAND,PLT1M	1

- Parts with "•" are component parts or sub-assemblies of the assembly appearing immediately above them.
- Parts with "●" indicates the Service parts.

FIG. 5 PAPER CONVEYING SECTION II (Metric)

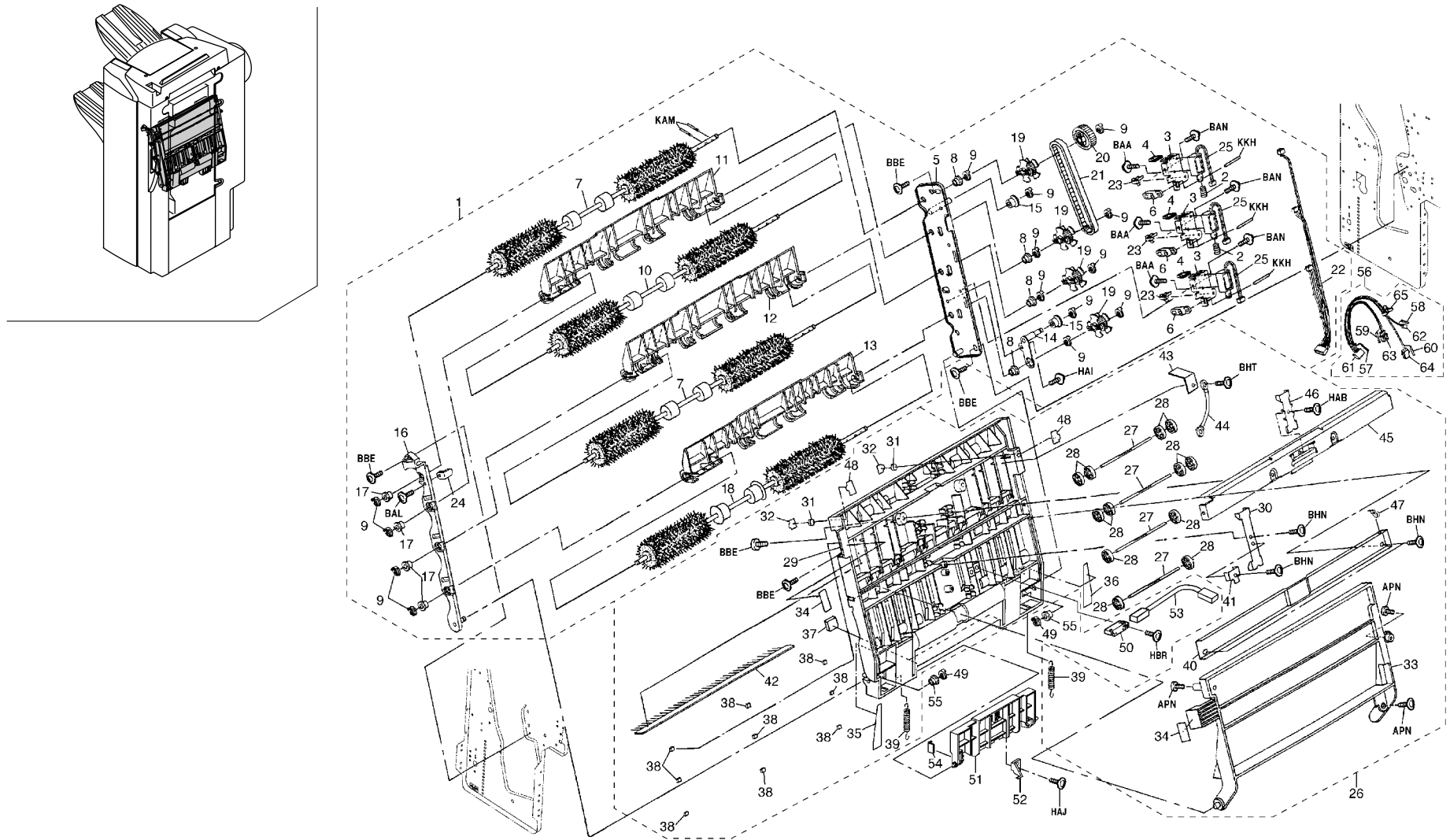

FIG. 5 PAPER CONVEYING SECTION II (Metric)

3CG

SP	Ref. No.	Part. No.	Description	Quantity	
				230V	240V
	1	3C100101	FEED SHIFT UNIT ASS'Y(METRIC)	1	1
	2	•73226040	SPRING,REVERSE SOLENOID	2	2
	3	•3AK08201	MOUNT,FEED SHIFT SOLENOID	3	3
	4	•M2104200	EDGING EDS-1	3	3
	5	•3AK08021	REAR FRAME,FEED SHIFT(METRIC)	1	1
	6	•3BD08060	LEVER,FEED SHIFT SOLENOID	3	3
●	7	•3C108040	ROLLER B1,FEED SHIFT	2	2
	8	•29806810	BUSHING,6 REGISTRATION	4	4
●	9	•34806150	STOPPER 5	14	14
●	10	•3BD08040	ROLLER B,FEED SHIFT	1	1
	11	•3C108080	GUIDE A3,FEED SHIFT	1	1
	12	•3C108090	GUIDE B4,FEED SHIFT	1	1
	13	•3C108100	GUIDE A4R,FEED SHIFT	1	1
	14	•3AK08210	TENSION PLATE,FEED SHIFT	1	1
●	15	•48928800	PULLEY,TIMING BELT	2	2
	16	•3AK08012	FRONT FRAME,FEED SHIFT(METRIC)	1	1
●	17	•29806560	BUSHING 6	4	4
●	18	•3C108030	ROLLER A1,FEED SHIFT	1	1
●	19	•3AK08230	PULLEY 20,COUPLING	4	4
●	20	•3BD22250	GEAR 17,FEED SHIFT ROLLER	1	1
●	21	•3AK08320	UPPER BELT,FEED SHIFT(METRIC)	1	1
	22	•3AK27540	JUNCTION WIRING,PADDLE SOLENOID	1	1
	23	•M2107120	BINDING BAND SG-130	3	3
	24	•3AK08390	BASE,MAGNET FEED SHIFT	1	1
●	25	•3AK27040	SOLENOID,PADDLE	3	3
	26	3C100083	UPPER GUIDE FEED SHIFT ASS'Y(METRIC)	1	1
	27	•3AK08150	UPPER SHAFT,FEED SHIFT	4	4
●	28	•3BD08050	PULLEY,FEED SHIFT	12	12
	29	•3C108020	UPPER GUIDE,FEED SHIFT(METRIC)	1	1
	30	•3AK08070	PLATE SPRING,FEED SHIFT PULLEY(METRIC)	1	1
	31	•3AK08371	MAGNET,FEED SHIFT	2	2
	32	•3AK08420	SEAL,MAGNET FEED SHIFT	2	2
	33	•3AK08183	GUIDE,FEED SHIFT SUB	1	1
	34	•3AK05050	LABEL,FEED SHIFT GUIDE	2	2
	35	•3AK08490	FRONT FILM,PAPER EDGE GUIDE	1	1
	36	•3AK08500	REAR FILM,PAPER EDGE GUIDE	1	1
	37	•3C108300	UPPER CUSHION,TURN	2	2
	38	•3AK08480	CUSHION,FEED SHIFT GUIDE	9	9
	39	•75914020	RELEASE SPRING MAIN DEVELOPING UNIT	2	2
	40	•3BD08070	LOWER REINFORCEMENT,FEED SHIFT GUIDE	1	1

SP	Ref. No.	Part. No.	Description	Quantity	
				230V	240V
	41	•3C108410	HOLDER,FEED SHIFT PULLEY	1	1
●	42	•18393020	PARTS,STATIC ELIMINATOR EJECT(SP)	1	1
	43	•3AK08451	PLATE SPRING,GROUND WIRE FEED SHIFT	1	1
	44	•63568070	GROUND WIRE,FEED ROLLER	1	1
	45	•3AK08170	REINFORCEMENT,FEED SHIFT GUIDE	1	1
	46	•3AK08380	PLATE SPRING,FEED SHIFT PULLEY(METRIC B)	1	1
	47	•M2607010	BINDING BAND,PLT1M	1	1
	48	•3AK08570	LID,MAGNET	2	2
●	49	34806150	STOPPER 5	2	2
●	50	63227150	SWITCH L,FEED	1	1
	51	3C108210	UPPER TURN PLATE	1	1
	52	3C108220	STOPPER,TURN	1	1
	53	3C127560	LOWER JUNCTION WIRING,CONVEYING SENSOR	1	1
	54	3AK08430	SPACER,TURN	1	1
●	55	76514080	BUSHING 6 DRIVE	2	2
	56	3AK27560	JUNCTION WIRING,PAPER REGISTRATION SOLEN	1	1
	57	•J0452900	PIN,DF3-EP2428PC(HIROSE)	7	7
	58	•J0450900	SOCKET,DF3-2428SC(HIROSE)	2	2
	59	•J0242900	PIN SM,BYP-001T-0.6	3	3
	60	•J0250900	SOCKET,BHF-001T-0.8SS	2	2
	61	•J0453070	PRUG,DF3-7EP-2C(HIROSE)	1	1
	62	•J0450020	PLUG,DF3-2S-2C(HIROSE)	1	1
	63	•J0243030	RECEPTACLE SM 3P,SMR-03V-B	1	1
	64	•J0241020	PLUG SM 2P,SMP-02V-BC	1	1
	65	•M2607010	BINDING BAND,PLT1M	1	1

- Parts with "•" are component parts or sub-assemblies of the assembly appearing immediately above them.
- Parts with "●" indicates the Service parts.

FIG. 6 MIDDLE TRAY I

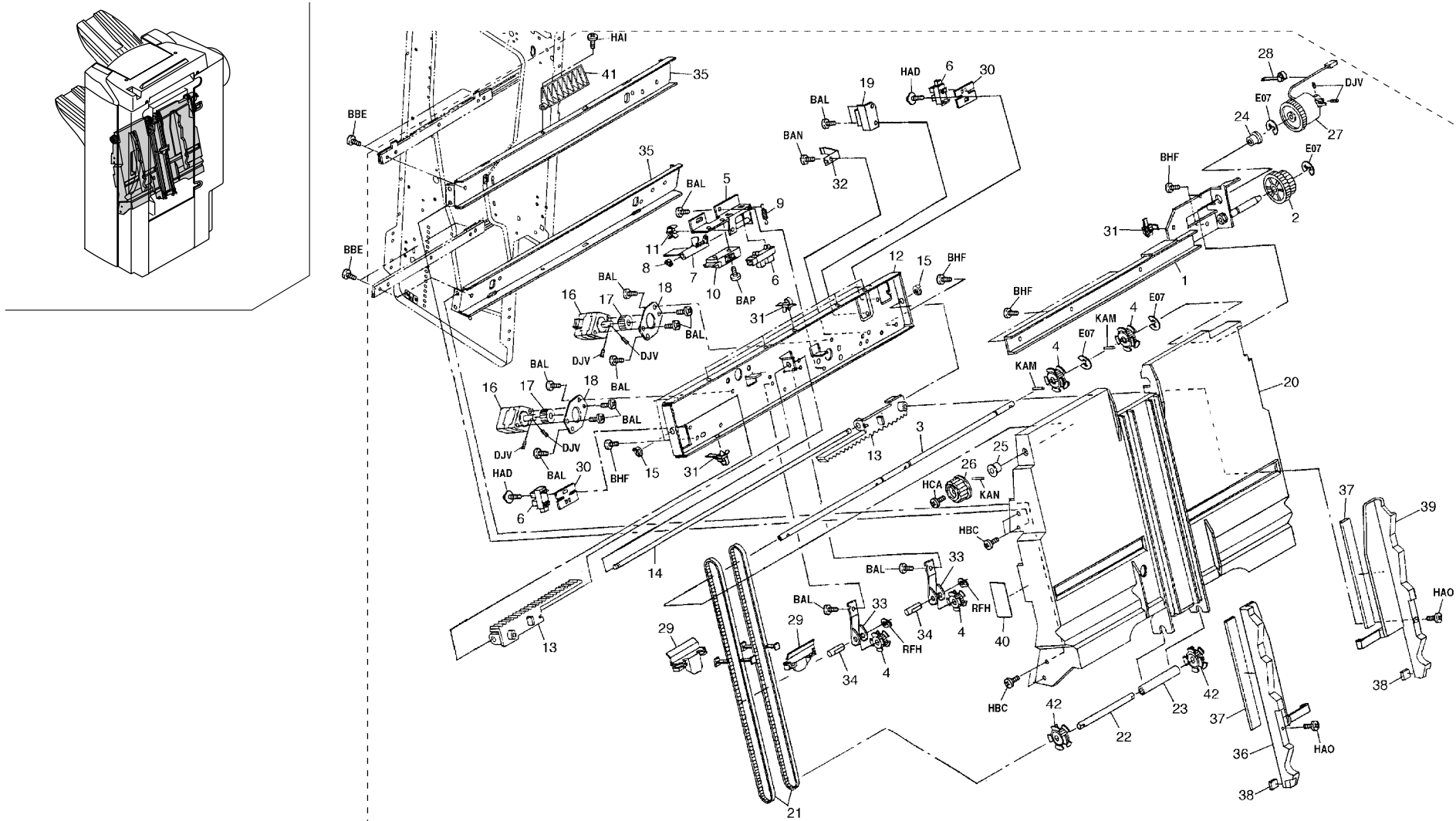



FIG. 6 MIDDLE TRAY I

3CG

SP	Ref. No.	Part. No.	Description	Quantity		
				120V	230V	240V
		3C100070	MIDDLE TRAY ASS'Y	1	1	1
●	1	•3BD07010	MOUNT,MIDDLE DRIVE	1	1	1
	2	•3BD07030	GEAR 24/33,IDLE	1	1	1
	3	•3BD07020	SHAFT,MIDDLE DRIVE	1	1	1
●	4	•3AK07230	PULLEY 20S3M	4	4	4
	5	•3AK07240	MOUNT,MIDDLE BELT SW	1	1	1
●	6	•35327400	SWITCH,FEED	3	3	3
	7	•3AK07250	LEVER,MIDDLE BELT SW	1	1	1
●	8	•65016080	STOP RING E3	1	1	1
	9	•63822350	SPRING,JOINT	1	1	1
●	10	•78727110	JAM DETECTION SWITCH	1	1	1
	11	•M2109260	WIRE SADDLE,YMC-05-H-0(KITAGAWA)	1	1	1
	12	•3AK07060	MOUNT,CURSOR	1	1	1
	13	•3AK07050	RACK,MIDDLE	2	2	2
	14	•3AK07070	SHAFT,MIDDLE GUIDE	1	1	1
●	15	•63511220	STOP RING,4	2	2	2
●	16	•18393080	PARTS,MOTOR MOVING(SP)	2	2	2
●	17	•3AK07080	GEAR,CURSOR MOTOR	2	2	2
	18	•3AK07310	RETAINER,CURSOR MOTOR	2	2	2
	19	•60804120	MAGNET CATCH	1	1	1
	20	•3AK07010	TRAY,MIDDLE	1	1	1
●	21	•3AK07150	BELT,MIDDLE CONVEYING	1	1	1
	22	•3AK07200	SHAFT,MIDDLE IDLE	1	1	1
	23	•3AK07330	COLLAR,PULLEY RETAINING	1	1	1
●	24	•67322230	BUSHING 8	1	1	1
●	25	•49028112	BUSHING 8,LOWER REG.ROLLER	1	1	1
	26	•33406500	HANDLE,REGISTRATION	1	1	1
●	27	•3BD07050	CLUTCH,MIDDLE TRAY	1	1	1
	28	•M2607010	BINDING BAND,PLT1M	1	1	1
	29	•3AK07160	MOVING PLATE,MIDDLE CONVEYING	2	2	2
	30	•3AK07090	MOUNT,MIDDLE PI	2	2	2
	31	•M2107120	BINDING BAND SG-130	7	7	7
	32	•18313150	GROUND PLATE,PARTITION	1	1	1
	33	•3BD07060	TENSION PLATE,MIDDLE CONVEYING	2	2	2
	34	•3AK07220	SHAFT,MIDDLE TENSION	2	2	2
	35	•3AK07021	MOUNT,MIDDLE SLIDER	2	2	2
	36	•3C107080	FRONT CURSOR,MIDDLE	1	1	1
	37	•3AK07360	CUSHION,CURSOR	2	2	2
	38	•78710370	CUSHION UPPER LOOP	2	2	2
	39	•3C107090	REAR CURSOR,MIDDLE	1	1	1

SP	Ref. No.	Part. No.	Description	Quantity		
				120V	230V	240V
	40	•3AK05090	LABEL B,MIDDLE TRAY	1	1	1
●	41	•3BD07040	GUIDE,MOVING PLATE	1	1	1
	42	•3BD07080	PULLEY 22,MIDDLE TRAY IDLE	2	2	2

- Parts with "•" are component parts or sub-assemblies of the assembly appearing immediately above them.
- Parts with "●" indicates the Service parts.

FIG. 7 MIDDLE TRAY II

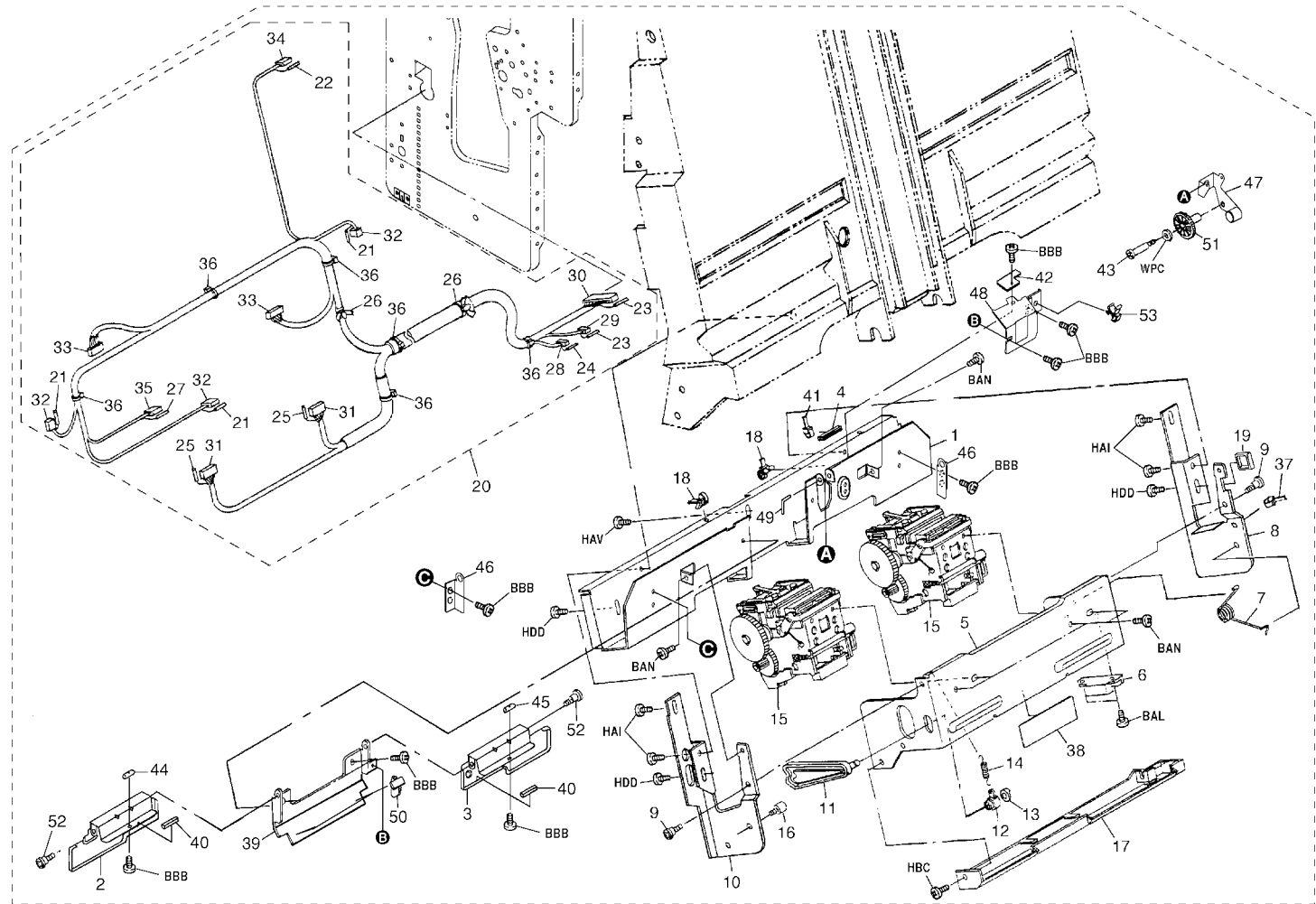
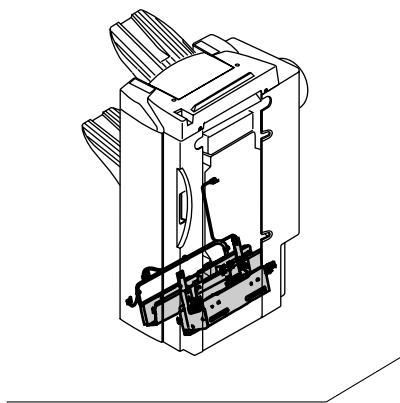

FIG. 7 MIDDLE TRAY II

3CG

SP	Ref. No.	Part. No.	Description	Quantity		
				120V	230V	240V
		3C100070	MIDDLE TRAY ASS'Y	1	1	1
	1	•3C107010	BASE,MIDDLE TRAY	1	1	1
	2	•3C107020	FRONT GUIDE,PAPER HOLDER	1	1	1
	3	•3C107030	REAR GUIDE,PAPER HOLDER	1	1	1
	4	•M2104100	EDGING CE-012	1	1	1
	5	•3AK07100	MOUNT,STAPLER	1	1	1
	6	•60804120	MAGNET CATCH	1	1	1
	7	•3AK07320	SPRING,STAPLER ROTATING	1	1	1
	8	•3AK07120	REAR RETAINER,STAPLER	1	1	1
	9	•29820110	FRONT PIN,FULCRUM	2	2	2
	10	•3AK07110	FRONT RETAINER,STAPLER	1	1	1
	11	•3AK07140	FRONT SUPPORT PLATE,STAPLER	1	1	1
	12	•3AK07340	GUIDE,SUPPORT PLATE STAPLER	1	1	1
●	13	•63511220	STOP RING,4	1	1	1
	14	•65710370	SPRING,ORIGINAL DETECTION HOLDER	1	1	1
●	15	•3AK27050	STAPLER	2	2	2
	16	•48128807	PIN,FRAME	1	1	1
	17	•3AK07130	GUIDE,STAPLER WIRE	1	1	1
	18	•M2107120	BINDING BAND SG-130	2	2	2
	19	•M2104260	EDGING,EDS-0607U(KITAGAWA)	1	1	1
	20	•3AK27510	WIRE,MIDDLE TRAY	1	1	1
	21	••J0150900	CONTACTOR,175161-1(AMP)	12	12	12
	22	••J0250900	SOCKET,BHF-001T-0.8SS	2	2	2
	23	••J5080900	SOCKET,BPHD-002T-P0.5(JST)	43	43	43
	24	••J0421900	CONTACTOR,DF1B-2428SC(HIROSE)	8	8	8
	25	••J0311900	SOCKET,5479PBTL	22	22	22
	26	••M2107120	BINDING BAND SG-130	2	2	2
	27	••J0080900	SOCKET,170205-1(AMP)	3	3	3
	28	••J0421080	SOCKET 8P,DF1B-8DS-2.5RC	1	1	1
	29	••J5080120	RECEPTACLE,PHDR-12VS(JST)	1	1	1
	30	••J5080320	RECEPTACLE,PHDR-32VS(JST)	1	1	1
	31	••J0311130	RECEPTACLE,5480-13(MOLEX)	2	2	2
	32	••J0150030	RECEPTACLE,175778-3(AMP)	4	4	4
	33	••J0200060	PLUG,PHR-6(JST)	2	2	2
	34	••J0241020	PLUG SM 2P,SMP-02V-BC	1	1	1
	35	••J0080030	RECEPTACLE EI 3P,171822-3	1	1	1
	36	••M2607010	BINDING BAND,PLT1M	6	6	6
	37	•M2107200	BAND,SG-110 V0(KITAGAWA)	1	1	1
	38	•3AK05040	LABEL,MIDDLE TRAY	1	1	1
	39	•3C107050	REINFORCEMENT,PAPER HOLDER	1	1	1

SP	Ref. No.	Part. No.	Description	Quantity		
				120V	230V	240V
	40	•3C107070	SPONGE,PAPER HOLDER	2	2	2
	41	•M2607010	BINDING BAND,PLT1M	1	1	1
●	42	•3AK01030	MIDDLE SENSOR ASS'Y	1	1	1
	43	•29802230	PIN,CONNECTOR	1	1	1
	44	•3C107060	WEIGHT,PAPER GUIDE	1	1	1
	45	•3C107130	REAR WEIGHT,PAPER GUIDE	1	1	1
	46	•3C107040	SUPPORT PLATE,PAPER HOLDER	2	2	2
	47	•3C107100	MOUNT,PULSE DISC	1	1	1
	48	•3C107110	MOUNT,PI	1	1	1
	49	•3C107120	SHAFT,PULSE DISC	1	1	1
	50	•3C107140	GUIDE,STACK	2	2	2
	51	•29707331	DUPLEX PULSE PLATE	1	1	1
	52	•73918080	PIN,CLEANING BLADE	2	2	2
	53	•M2109260	WIRE SADDLE,YMC-05-H-0(KITAGAWA)	1	1	1

- Parts with "•" are component parts or sub-assemblies of the assembly appearing immediately above them.
- Parts with "●" indicates the Service parts.

FIG. 8 DRIVING SECTION I

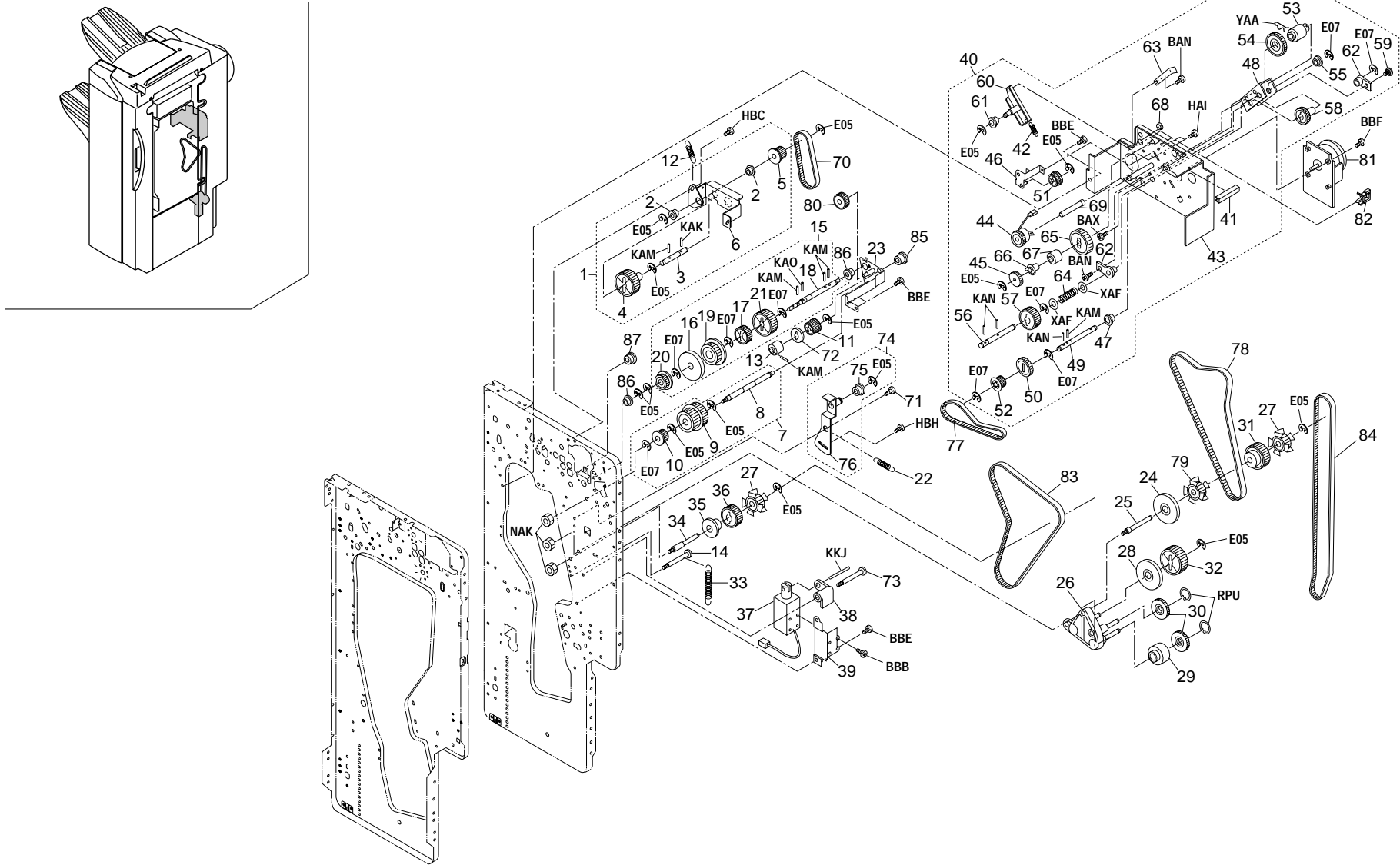

FIG. 8 DRIVING SECTION I

3CG

SP	Ref. No.	Part. No.	Description	Quantity		
				120V	230V	240V
●	1	3C100140	PUNCH DRIVE ASS'Y	1	1	1
	2	•74808080	BEARING,686ZZNR	2	2	2
	3	•3C122110	SHAFT 14/29,IDLE	1	1	1
●	4	•3AK22030	GEAR 29,IDLE	1	1	1
●	5	•3AK22020	PULLEY 14,IDLE	1	1	1
	6	•3C122100	SUPPORT PLATE,IDLE PUNCH	1	1	1
	7	3BD00100	MAIN DRIVE ASS'Y	1	1	1
	8	•3BD22080	SHAFT,MAIN DRIVE	1	1	1
●	9	•3BD22030	PULLEY 37/48,DRIVE	1	1	1
●	10	•72622141	TENSION PULLEY 20	1	1	1
●	11	69914030	GEAR,MAGNET ROLLER	1	1	1
	12	63511091	SPRING,ADF HOOK	1	1	1
●	13	33906070	TORQUE LIMITER,PAPER FEED	1	1	1
	14	29802230	PIN,CONNECTOR	1	1	1
	15	3C100150	IDLE ASS'Y	1	1	1
●	16	•3C122130	COLLAR L,PUNCH DRIVE	1	1	1
●	17	•19522130	GEAR 30	1	1	1
	18	•3C122120	SHAFT 45/28/40/30,IDLE	1	1	1
●	19	•3AK22040	PULLEY 40,FEED IN	1	1	1
●	20	•34922280	PULLEY 30	1	1	1
●	21	•3AK22070	GEAR 45,MOTOR IDLE	1	1	1
	22	29407191	TENSION SPRING,PF	1	1	1
	23	3BD22010	RETAINER,MAIN DRIVE	1	1	1
	24	3B622040	COLLAR 21	1	1	1
	25	3AK22200	PIN,DRIVE SHIFT	1	1	1
	26	3AK22320	TURN PLATE,DRIVE SHIFT	1	1	1
●	27	3AK08230	PULLEY 20,COUPLING	2	2	2
●	28	3AK22390	COLLAR 27,DRIVE SHIFT	1	1	1
●	29	3AK22410	COLLAR 13,DRIVE SHIFT	1	1	1
●	30	18314040	GEAR 13,PARTITION JOINT	2	2	2
●	31	3C122210	GEAR 27,DRIVE SHIFT	1	1	1
●	32	36714130	GEAR 27,DEVELOPING	1	1	1
	33	35912480	SPRING,SCANNER WIRE	1	1	1
	34	3AK22300	PIN,IDLE FEED SHIFT	1	1	1
●	35	3AK22290	COLLAR 22,DRIVE SHIFT	1	1	1
●	36	3AK08220	GEAR 22,FEED SHIFT	1	1	1
●	37	3AK27580	SOLENOID,DRIVE SWITCH	1	1	1
	38	3AK22330	LEVER,DRIVE SHIFT	1	1	1
	39	3AK22340	MOUNT,SOLENOID SHIFT	1	1	1
	40	3C100130	DRIVE UNIT ASS'Y	1	1	1

SP	Ref. No.	Part. No.	Description	Quantity		
				120V	230V	240V
	41	•M2104100	EDGING CE-012	1	1	1
	42	•48529303	SPRING,TENSION	1	1	1
	43	•3C122010	SUPPORT PLATE,DRIVE	1	1	1
●	44	•36993200	PARTS,CLUTCH PAPER FEED,SP	1	1	1
●	45	•34922570	GEAR 23,DEVELOPING	1	1	1
	46	•3BD22210	MOUNT,PADDLE IDLE	1	1	1
	47	•71807040	BUSHING 8,PF	1	1	1
	48	•3AK22190	SUPPORT PLATE,IDLE JOINT	1	1	1
	49	•3BD22120	SHAFT 40/21,IDLE	1	1	1
●	50	•3BD22220	GEAR 31,FEED SHIFT DRIVE	1	1	1
●	51	•3BD22240	GEAR 20/22,PADDLE IDLE	1	1	1
●	52	•68322210	PULLEY,21 IDLE	1	1	1
●	53	•3AK22080	TORQUE LIMITER,MIDDLE DRIVE	1	1	1
●	54	•3AK22140	GEAR 40,MIDDLE DRIVE	1	1	1
●	55	•67322230	BUSHING 8	1	1	1
	56	•3AK22100	SHAFT,IDLE JOINT	1	1	1
●	57	•29721040	GEAR,24 SB	1	1	1
●	58	•3AK22060	GEAR 33,THRUST	1	1	1
	59	•60116080	PIN RAIL DEV.	1	1	1
	60	•3BD22200	TENSION PLATE C,DRIVE	1	1	1
●	61	•48928800	PULLEY,TIMING BELT	1	1	1
●	62	•74718091	BUSHING CLEANING UNIT	2	2	2
	63	•3AK22370	PLATE SPRING,DRIVE GROUND	1	1	1
	64	•73818100	SPRING, BLADE THRUST	1	1	1
●	65	•3BD22230	GEAR 42,PADDLE INPUT	1	1	1
	66	•3BD22150	JOINT,TORQUE LIMITER	1	1	1
●	67	•3BD22160	TORQUE LIMITER,DRIVE	1	1	1
	68	•M1203240	OPEN BUSHING,OCB-500	1	1	1
	69	•3BD22130	PIN,PADDLE CLUTCH(M4)	1	1	1
●	70	3BD22110	BELT,PUNCH DRIVE	1	1	1
	71	72918050	PIN,BLADE ARM	1	1	1
●	72	3AX22030	JOINT,TORQUE LIMITER	1	1	1
	73	71821221	PIN,LOOP GUIDE	1	1	1
	74	3C100240	TENSION PLATE FEED SHIFT DRIVE ASS'Y	1	1	1
●	75	•48928800	PULLEY,TIMING BELT	1	1	1
	76	•3C122090	TENSION PLATE A,FEED SHIFT DRIVE	1	1	1
●	77	3C122020	BELT 378,DRIVE	1	1	1
●	78	3C122030	BELT 552,FEED SHIFT DRIVE	1	1	1
●	79	3BD22060	PULLEY 22,COUPLING	1	1	1
●	80	2AL06110	GEAR 25	1	1	1

- Parts with "•" are component parts or sub-assemblies of the assembly appearing immediately above them.
- Parts with "●" indicates the Service parts.

FIG. 8 DRIVING SECTION I

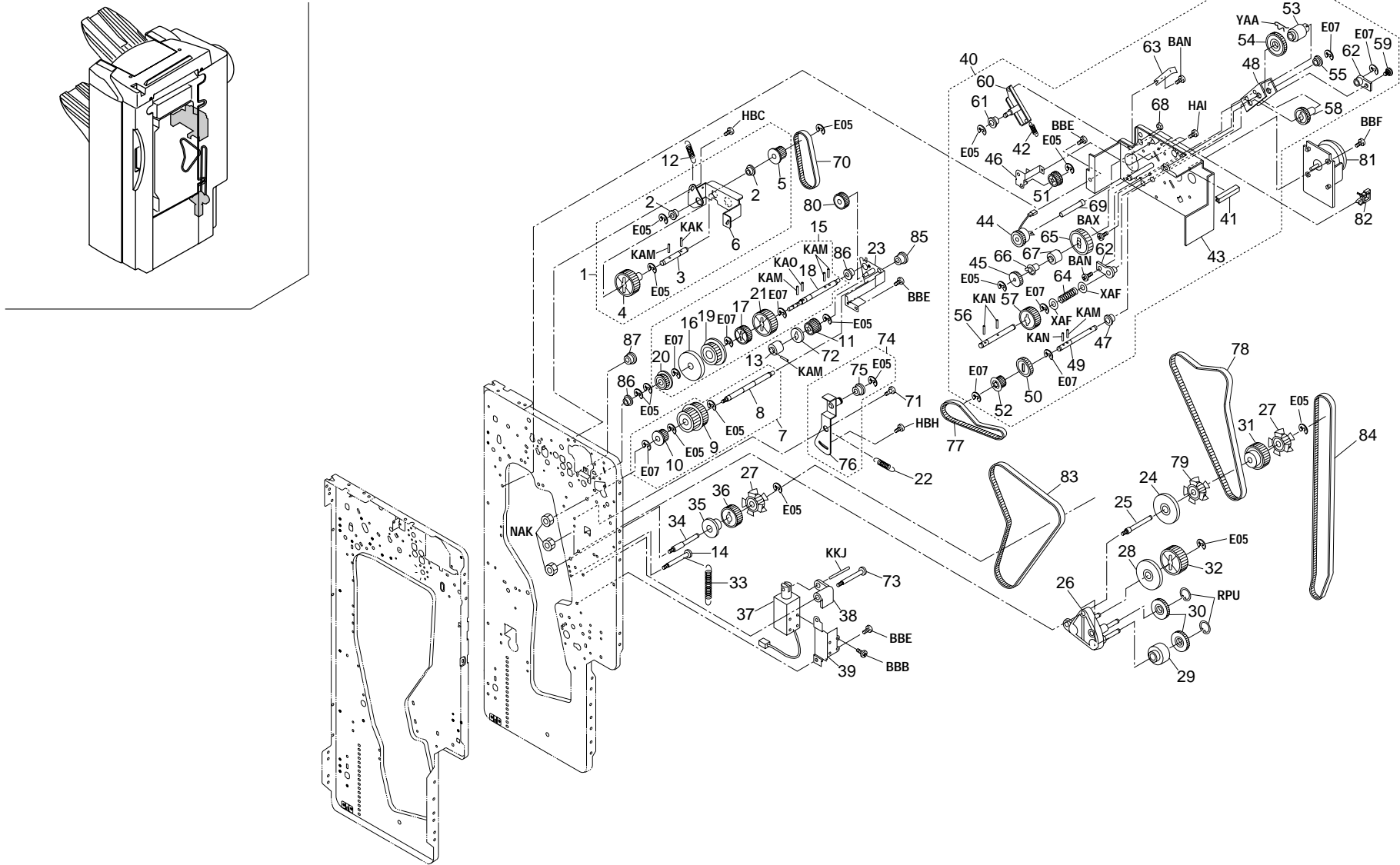

FIG. 8 DRIVING SECTION I

3CG

SP	Ref. No.	Part. No.	Description	Quantity		
				120V	230V	240V
●	81	3BD27010	MOTOR,MAIN	1	1	1
	82	M2109230	WIRE SADDLE,LWS-3S(KITAGAWA)	2	2	2
●	83	3AK08340	LOWER BELT,FEED SHIFT(METRIC)		1	1
●	83	3AK08350	LOWER BELT,FEED SHIFT(INCH)	1		
●	84	3BD22180	BELT,EJECT DRIVE	1	1	1
●	85	29806560	BUSHING 6	1	1	1
●	86	74808080	BEARING,686ZZNR	2	2	2
●	87	48928800	PULLEY,TIMING BELT	1	1	1

- Parts with "●" are component parts or sub-assemblies of the assembly appearing immediately above them.
- Parts with "●" indicates the Service parts.

FIG. 9 DRIVING SECTION II

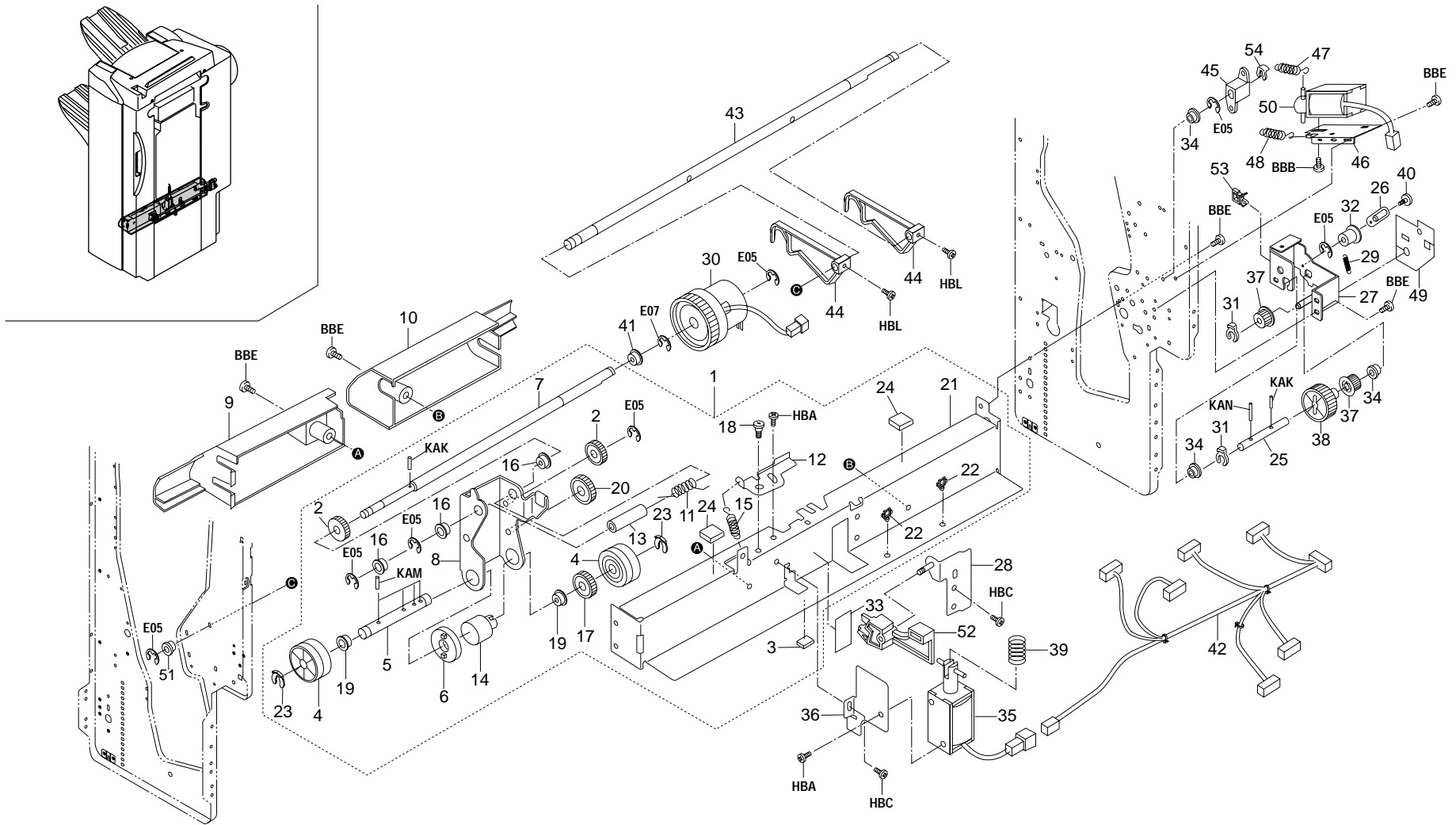



FIG. 9 DRIVING SECTION II

3CG

SP	Ref. No.	Part. No.	Description	Quantity		
				120V	230V	240V
●	1	3C100212	STAY LEADING FEED ASS'Y	1	1	1
	2	•2A116190	GEAR,TRANSFER	2	2	2
	3	•3AK08480	CUSHION,FEED SHIFT GUIDE	1	1	1
●	4	•3C108110	PULLEY,LEADING FEED	2	2	2
	5	•3C108120	LOWER SHAFT,LEADING FEED	1	1	1
	6	•3C108130	HOLDER,TORQUE LIMITER	1	1	1
	7	•3C108140	UPPER SHAFT,LEADING FEED	1	1	1
	8	•3C108150	TURN PLATE,LEADING FEED	1	1	1
	9	•3C108190	FRONT GUIDE,LEADING FEED	1	1	1
	10	•3C108200	REAR GUIDE,LEADING FEED	1	1	1
	11	•3C108240	LOWER SPRING,TURN	1	1	1
	12	•3C108250	ADJUSTING PLATE,TURN	1	1	1
	13	•3C108260	COLLAR,TURN SPRING	1	1	1
●	14	•33906430	TORQUE LIMITER,BYPASS	1	1	1
	15	•61716110	SPRING,CLEANING DRIVE TENSION	1	1	1
●	16	•68822330	BEARING,DRIVE	3	3	3
●	17	•73210370	GEAR 18,LOOP	1	1	1
	18	•73918080	PIN,CLEANING BLADE	1	1	1
	19	•74808140	BEARING,LNR-1360ZZR	2	2	2
●	20	•75122090	GEAR , FRONT	1	1	1
	21	•3C108180	STAY,LEADING FEED	1	1	1
	22	•M2105210	MINI CLAMP,UAMS-02WL-0(KITAGAWA)	2	2	2
●	23	•34806150	STOPPER 5	2	2	2
	24	•3C108300	UPPER CUSHION,TURN	2	2	2
	25	3C122170	SHAFT,LEADING FEED DRIVE	1	1	1
	26	3C122190	TENSION PLATE,LEADING FEED DRIVE	1	1	1
	27	3C122160	MOUNT,LEADING FEED DRIVE	1	1	1
	28	3C108160	MOUNT,TURN LEVER	1	1	1
	29	3C122200	SPRING,LEADING FEED DRIVE TENSION	1	1	1
●	30	3BD07050	CLUTCH,MIDDLE TRAY	1	1	1
●	31	2A806250	RING STOPPER	2	2	2
●	32	48928800	PULLEY,TIMING BELT	1	1	1
	33	2BL27670	SHEET RADIATOR	1	1	1
	34	73210450	BUSH, 6	3	3	3
●	35	3C127030	UPPER SOLENOID,TURN	1	1	1
	36	3AK08251	MOUNT,SOLENOID TURN	1	1	1
●	37	61715510	PULLEY,SHUTTER	2	2	2
●	38	3C122180	GEAR Z29,LEADING FEED DRIVE	1	1	1
	39	3C108290	SPRING,TURN SOLENOID	1	1	1
	40	72918050	PIN,BLADE ARM	1	1	1

SP	Ref. No.	Part. No.	Description	Quantity		
				120V	230V	240V
●	41	60912270	BEARING,688ZZ	1	1	1
	42	3C127531	JUNCTION WIRING,FEED SOLENOID	1	1	1
	43	3C108330	SHAFT,HOLDER	1	1	1
	44	3C108380	HOLDER,PAPER(INCH)	2		
	44	3C108310	HOLDER,PAPER(METRIC)		2	2
	45	3C108320	LEVER,HOLDER	1	1	1
	46	3C108350	MOUNT,HOLDER SOLENOID	1	1	1
	47	3C108360	SPRING,HOLDER SOLENOID	1	1	1
	48	3C108370	SPRING,HOLDER LEVER	1	1	1
	49	3C108400	FILM,LEADING FEED DRIVE	1	1	1
●	50	3C127040	SOLENOID,LEADING REGISTRATION	1	1	1
●	51	76514080	BUSHING 6 DRIVE	1	1	1
	52	3C108170	UPPER LEVER,TURN	1	1	1
	53	M2109350	WIRE SADDLE,YMC-15-0(KITAGAWA)	1	1	1
●	54	34806140	STOPPER 4	1	1	1

- Parts with "•" are component parts or sub-assemblies of the assembly appearing immediately above them.
- Parts with "●" indicates the Service parts.



FIG. 10 ELECTRICAL COMPONENTS I

3CG

SP	Ref. No.	Part. No.	Description	Quantity		
				120V	230V	240V
	1	3AK20190	MOUNT BASE,TRAY DETECTION SENSOR	2	2	2
●	2	63227020	SWITCH,FEED	1	1	1
●	3	3AK28020	REAR STACK SENSOR PCB	1	1	1
	4	M1203240	OPEN BUSHING,OCB-500	3	3	3
	5	3AK26030	MOUNT,WIRE	2	2	2
	6	3C126010	MOUNT,MAIN PCB	1	1	1
	7	3C101020	INTERFACE WIRE ASS'Y	1	1	1
	8	•3AK27521	WIRE,INTERFACE	1	1	1
	9	•3AK26020	MOUNT,SIGNAL WIRE	1	1	1
	10	•M1203550	STRAIN RELEAF BUSHING,SR-7W-2	1	1	1
	11	•3C127600	JUNCTION WIRING,INTERFACE	1	1	1
●	12	3CG01011	MAIN PCB ASS'Y	1	1	1
●	13	•3CG27011	IC,ROM	1	1	1
●	14	35327400	SWITCH,FEED	2	2	2
●	15	36827140	SWITCH A,INTERLOCK	2	2	2
●	16	3AK28030	FRONT STACK SENSOR PCB	1	1	1
●	17	3AK27030	SWITCH,SET	1	1	1
	18	3AK02191	FRONT MOUNT,SAFETY SWITCH	1	1	1
	19	M2104200	EDGING EDS-1	1	1	1
	20	60804120	MAGNET CATCH	1	1	1
	21	M2107120	BINDING BAND SG-130	10	10	10
	22	M2109230	WIRE SADDLE,LWS-3S(KITAGAWA)	6	6	6
	23	M2104350	EDGING,EDS-0607M(KITAGAWA)	1	1	1
	24	M2105600	CLAMP,LS-10	4	4	4
	25	M1203220	OPEN BUSHING,OCB-625	1	1	1
	26	3C127520	JUNCTION WIRING,RELEASE SWITCH	1	1	1
	27	3C127510	JUNCTION WIRING,EJECT	1	1	1
	28	3AK07090	MOUNT,MIDDLE PI	2	2	2

- Parts with "•" are component parts or sub-assemblies of the assembly appearing immediately above them.
- Parts with "●" indicates the Service parts.

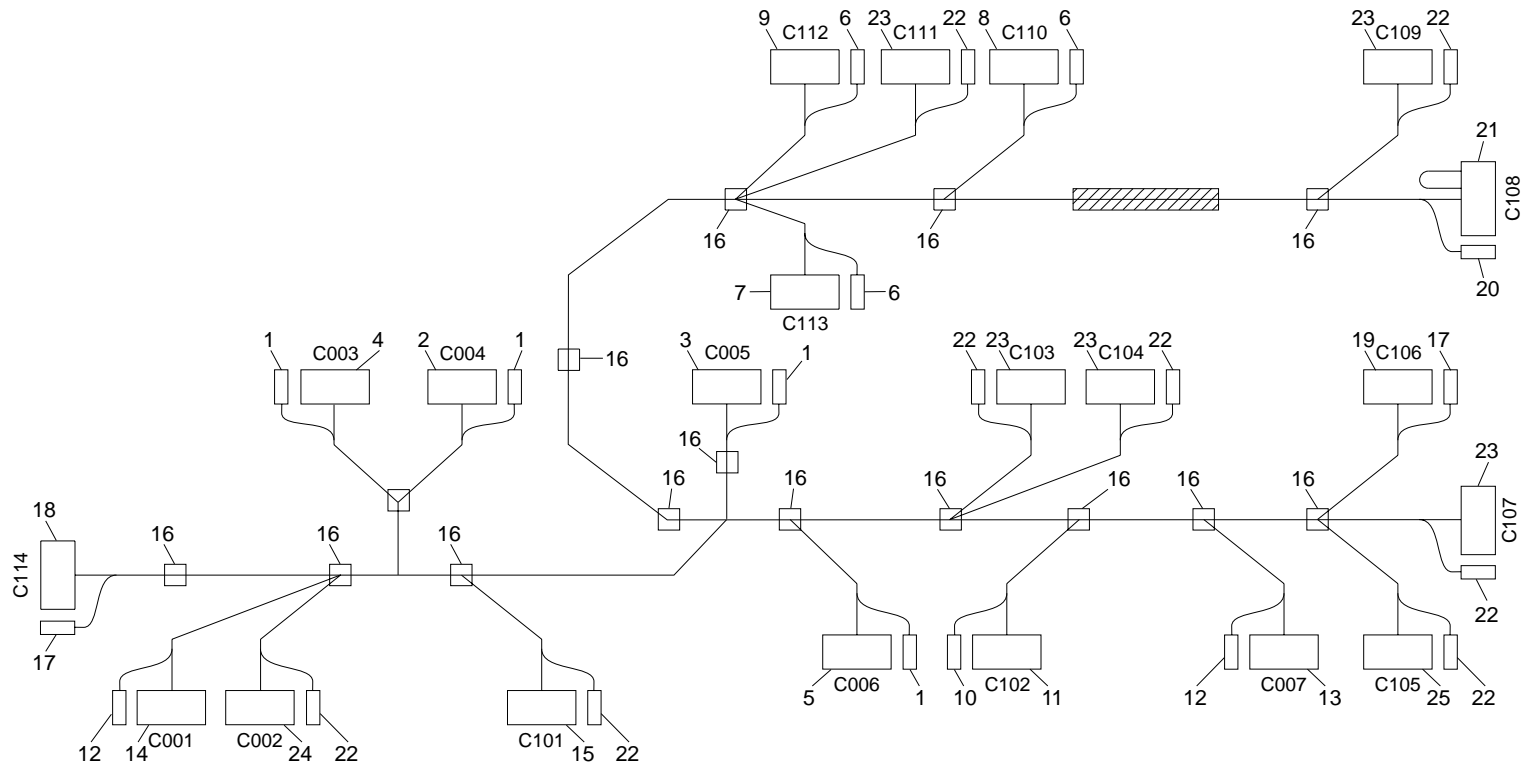

FIG. 11 ELECTRICAL COMPONENTS II

3CG

SP	Ref. No.	Part. No.	Description	Quantity		
				120V	230V	240V
		3C127500	WIRE,MAIN	1	1	1
	1	•J5080900	SOCKET,BPHD-002T-P0.5(JST)	2	2	2
	2	•J5080160	RECEPTACLE,PHDR-16VS(JST)	1	1	1
	3	•J5080200	RECEPTACLE,PHDR-20VS(JST)	1	1	1
	4	•J5080240	RECEPTACLE,PHDR-24VS(JST)	1	1	1
	5	•J5080260	RECEPTACLE,PHDR-26VS(JST)	1	1	1
	6	•J0250910	SOCKET NH,BHF-001T-0.8BS	6	6	6
	7	•J0241020	PLUG SM 2P,SMP-02V-BC	1	1	1
	8	•J0240020	PLUG SM 2P,SMP-02V-NC	1	1	1
	9	•J0240030	PLUG SM 3P,SMP-03V-NC	1	1	1
	10	•J0222900	PIN EL,LLM-01T-1.3E	2	2	2
	11	•J0223020	RECEPTACLE EL 2P,ELR-02V	1	1	1
	12	•J0272900	CONTACTOR,BVH-21T-P1.1(JST)	4	4	4
	13	•J0272020	RECEPTACLE,VH,2P,VHR-2N	1	1	1
	14	•J0272030	VH RECEPTACLE 3P,VHR-3N	1	1	1
	15	•J0154090	RECEPTACLE,179228-9(AMP)	1	1	1
	16	•M2607010	BINDING BAND,PLT1M	15	15	15
	17	•J0441900	CONTACTOR,DF11-2428SC	1	1	1
	18	•J0441240	RECEPTACLE,DF11-24DS-2C(HIROSE)	1	1	1
	19	•J0440200	PLUG,DF11-20DS-2C(HIROSE)	1	1	1
	20	•J0440900	PIN,DF11-EP2428PC(HIROSE)	9	9	9
	21	•J0443100	PLUG DF11-10DEP-2C(HIROSE)	1	1	1
	22	•J0153900	CONTACTOR,179518-1(AMP)	30	30	30
	23	•J0153030	RECEPTACLE,179228-3(AMP)	5	5	5
	24	•J0154040	RECEPTACLE,179228-4(AMP)	1	1	1
	25	•J0156030	RECEPTACLE,2-179228-3(AMP)	1	1	1

- Parts with "•" are component parts or sub-assemblies of the assembly appearing immediately above them.
- Parts with "●" indicates the Service parts.

FIG. 12 DECURLER

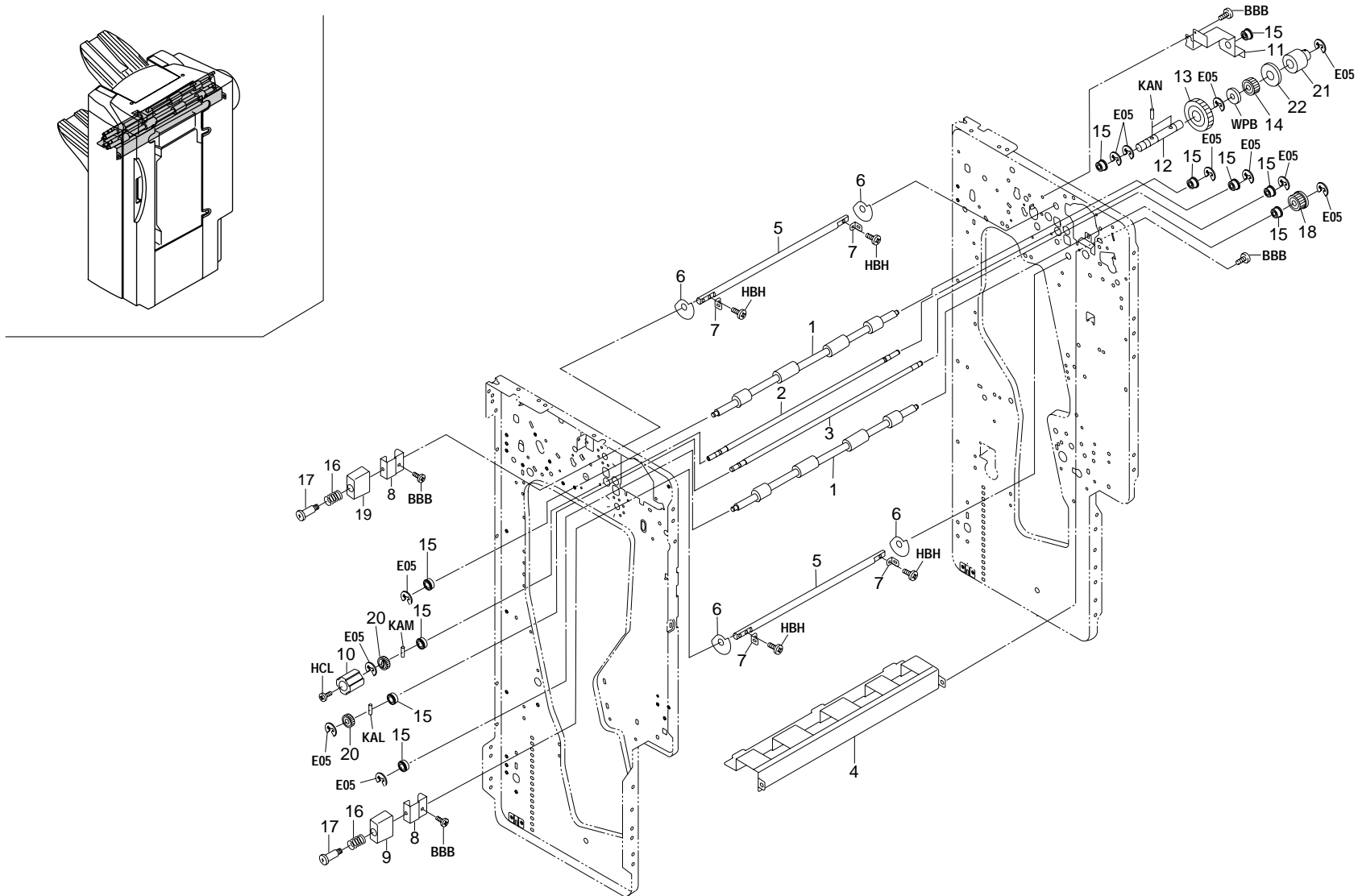

FIG. 12 DECURLER

3CG

SP	Ref. No.	Part. No.	Description	Quantity		
				120V	230V	240V
●	1	3C116010	ROLLER,DECURLER PRESSURE	2	2	2
	2	3C116020	LEFT ROLLER,DECURLER	1	1	1
	3	3C116030	RIGHT ROLLER,DECURLER	1	1	1
	4	3C116060	FRONT GUIDE,CONVEYING	1	1	1
	5	3C116090	SHAFT,DECURLER PRESSURE	2	2	2
	6	3C116100	CAM,DECURLER	4	4	4
	7	3C116110	MOUNT,DECURLER ADJUSTMENT	4	4	4
	8	3C116120	LEVER,DECURLER PRESSURE	2	2	2
	9	3C116130	LEVER,PRESSING PLATE	1	1	1
	10	3C116140	KNOB,DECURLER	1	1	1
	11	3C122050	MOUNT,DECURLER DRIVE	1	1	1
	12	3C122060	SHAFT,DECURLER DRIVE	1	1	1
●	13	3C122070	GEAR 34,DECURLER	1	1	1
●	14	3C122080	GEAR 27,DECURLER	1	1	1
●	15	74808080	BEARING,686ZZNR	10	10	10
	16	2AN02160	SPRING,LIFT UP	2	2	2
	17	72602220	PIN,HANDLE	2	2	2
●	18	75207370	GEAR16 ORIGINAL FEEDBACK	1	1	1
	19	3C116160	UPPER LEVER,PRESSING PLATE	1	1	1
●	20	2AC18280	GEAR 20, SPIRAL	2	2	2
●	21	33906430	TORQUE LIMITER,BYPASS	1	1	1
●	22	3AX22030	JOINT,TORQUE LIMITER	1	1	1

- Parts with "●" are component parts or sub-assemblies of the assembly appearing immediately above them.
- Parts with "●" indicates the Service parts.

### ACCESSORY

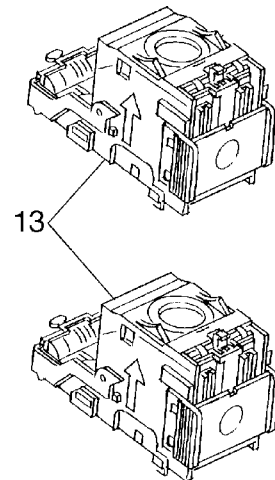
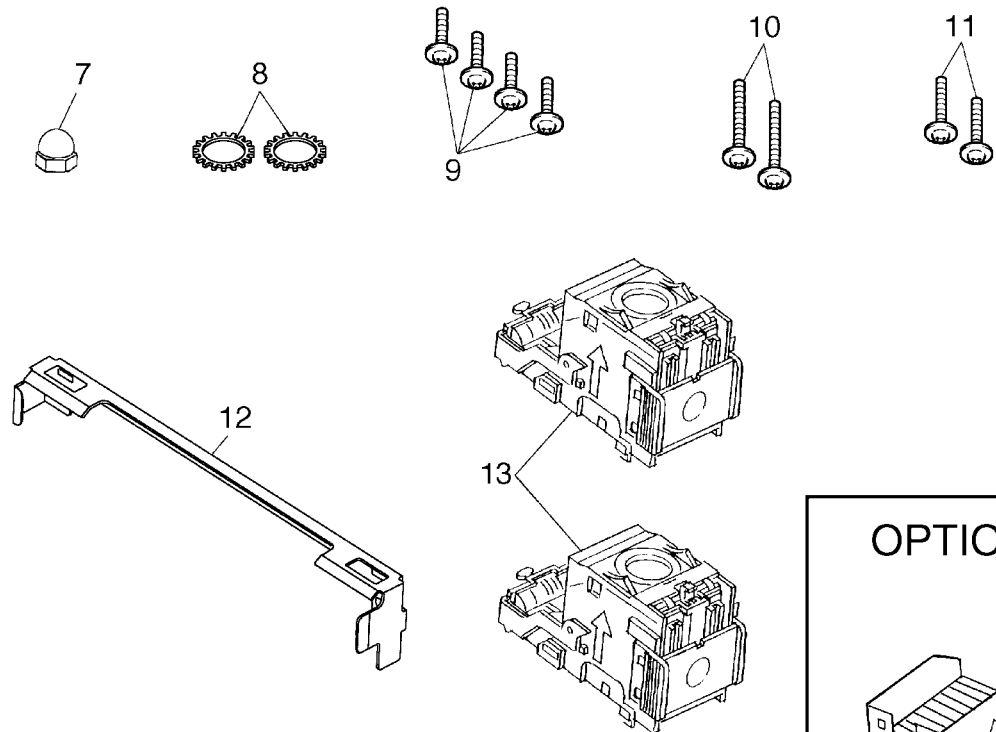
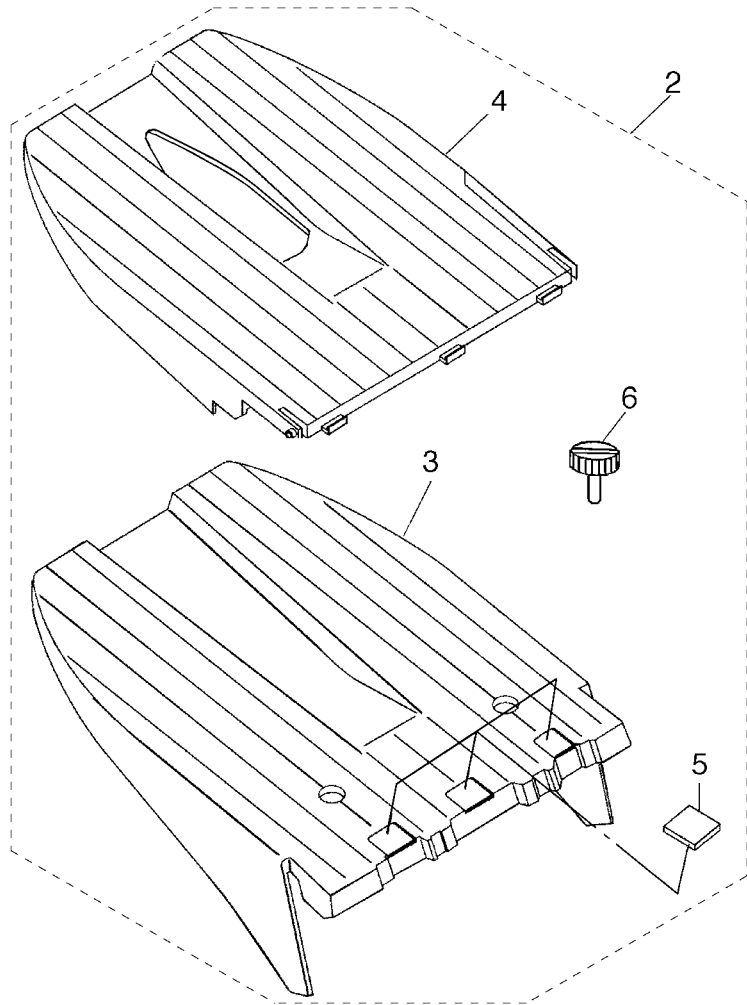

### OPTION

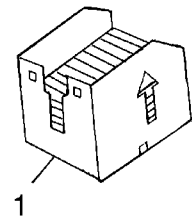



FIG. 13 ACCESSORIES & OPTION I

3CG

SP	Ref. No.	Part. No.	Description	Quantity		
				120V	230V	240V
	1	36882040	SET STAPLE CARTRIDGE	2	2	2
	2	3C100191	TRAY SET ASS'Y	1	1	1
●	3	•3C104071	TRAY,MAIN	1	1	1
●	4	•3C104080	TRAY,SUB	1	1	1
●	5	•3AK20240	VIBRATION INSULATOR,MAIN TRAY	3	3	3
	6	•33920500	RETAINING PIN, FIXING GUIDE	1	1	1
	7	C1054070	DOMED CAP NUT M4(CLASS 2)	1	1	1
	8	C4204000	CROWN WASHER TWM4	2	2	2
	9	B4104080	TRIPLE SCREW M4X08(CHROMIUM)	4	4	4
	10	B4104140	TRIPLE SCREW M4X14(CHROMIUM)	2	2	2
	11	B4304100	TRIPLE SCREW M4X10 (BLACK)	2	2	2
	12	3CD02010	RETAINER,FINISHER	1	1	1
●	13	3AK68010	CARTRIDGE,STAPLER	2	2	2

- Parts with "•" are component parts or sub-assemblies of the assembly appearing immediately above them.
- Parts with "●" indicates the Service parts.

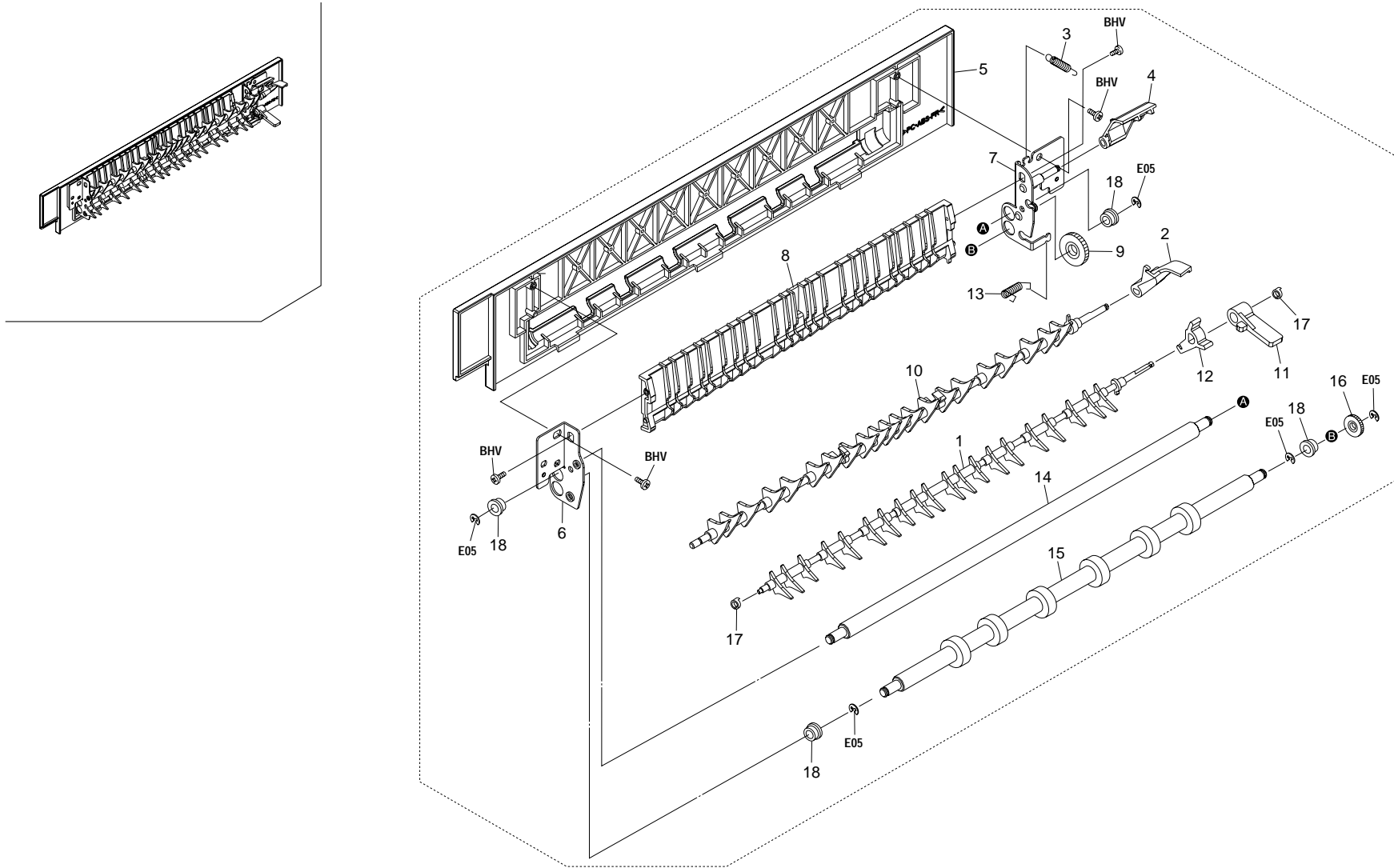

FIG. 14 OPTION II

3CG

SP	Ref. No.	Part. No.	Description	Quantity		
				120V	230V	240V
		3CG82010	SET,DECURLER COPY	1	1	1
	1	*2BJ21010	GUIDE CHANGE UP	1	1	1
	2	*2BJ21020	LEVER GUIDE CHANGE U	1	1	1
●	3	*2BJ21030	SPRING CHANGE UP	1	1	1
	4	*2BJ21040	LEVER CHANGE UP B	1	1	1
●	5	*2BJ60010	COVER FINISHER EJECT	1	1	1
	6	*2BJ60020	FRONT FRAME DECURL C	1	1	1
	7	*2BJ60030	REAR FRAME DECURL C	1	1	1
	8	*2BJ60040	GUIDE FINISHER EJECT	1	1	1
●	9	*2BL60040	GEAR 20 FEED SHIFT	1	1	1
	10	*2BL60060	GUIDE DU FEED SHIFT	1	1	1
	11	*2BL60070	LEVER CHANGE DU	1	1	1
	12	*2BL60080	LEVER CHANGE DU B	1	1	1
●	13	*2BL60140	SPRING DU CHANGE	1	1	1
	14	*2BL60100	ROLLER FINISHER UP	1	1	1
●	15	*2BL60120	LOWER ROLLER EXIT	1	1	1
●	16	*2BL60130	GEAR 13	1	1	1
●	17	*65016080	STOP RING E3	2	2	2
●	18	*68822330	BEARING,DRIVE	4	4	4

- Parts with "\*" are component parts or sub-assemblies of the assembly appearing immediately above them.
- Parts with "●" indicates the Service parts.

INDEX

3CG

SP	Part. No.	Description	Quantity			Fig. No.
			120V	230V	240V	
●	18313150	GROUND PLATE,PARTITION	1	1	1	6
●	18314040	GEAR 13,PARTITION JOINT	2	2	2	8
●	18314060	COLLAR,PARTITION JOINT	2	2	2	1
●	18327130	SOLENOID,STOPPER	1	1	1	4
●	18327140	SWITCH,PARTITION	1	1	1	2
●	18393020	PARTS,STATIC ELIMINATOR EJECT(SP)	1	1	1	5
●	18393080	PARTS,MOTOR MOVING(SP)	2	2	2	6
●	19020050	SPRING,PRESSURE	2	2	2	3
●	19522130	GEAR 30	1	1	1	8
●	2AC18280	GEAR 20,SPIRAL	2	2	2	12
●	2AL06110	GEAR 25	1	1	1	8
●	2AN02160	SPRING,LIFT UP	2	2	2	12
●	2A116190	GEAR,TRANSFER	2	2	2	9
●	2A806250	RING STOPPER	2	2	2	9
●	2BJ21010	GUIDE CHANGE UP	1	1	1	14
●	2BJ21020	LEVER GUIDE CHANGE U	1	1	1	14
●	2BJ21030	SPRING CHANGE UP	1	1	1	14
●	2BJ21040	LEVER CHANGE UP B	1	1	1	14
●	2BJ60010	COVER FINISHER EJECT	1	1	1	14
●	2BJ60020	FRONT FRAME DECURL C	1	1	1	14
●	2BJ60030	REAR FRAME DECURL C	1	1	1	14
●	2BJ60040	GUIDE FINISHER EJECT	1	1	1	14
●	2BL27670	SHEET RADIATOR	1	1	1	9
●	2BL60040	GEAR 20 FEED SHIFT	1	1	1	14
●	2BL60060	GUIDE DU FEED SHIFT	1	1	1	14
●	2BL60070	LEVER CHANGE DU	1	1	1	14
●	2BL60080	LEVER CHANGE DU B	1	1	1	14
●	2BL60100	ROLLER FINISHER UP	1	1	1	14
●	2BL60120	LOWER ROLLER EXIT	1	1	1	14
●	2BL60130	GEAR 13	1	1	1	14
●	2BL60140	SPRING DU CHANGE	1	1	1	14
●	29407191	TENSION SPRING,PF	2	2	2	2,8
●	29707331	DUPLEX PULSE PLATE	1	1	1	7
●	29721040	GEAR,24 SB	1	1	1	8
●	29802230	PIN,CONNECTOR	3	3	3	3,7,8
●	29806560	BUSHING 6	7	7	7	4,5,8
●	29806810	BUSHING,6 REGISTRATION	4	4	4	5
●	29820110	FRONT PIN,FULCRUM	2	2	2	7
●	29820420	PIN,BEARING	2	2	2	4
●	3AK00150	FRONT FRAME MAIN TRAY ASS'Y	1	1	1	3

SP	Part. No.	Description	Quantity			Fig. No.
			120V	230V	240V	
●	3AK00160	REAR FRAME MAIN TRAY ASS'Y	1	1	1	3
●	3AK00170	TENSION PLATE MAIN TRAY ASS'Y	2	2	2	3
●	3AK00180	MAIN TRAY DRIVE ASS'Y	1	1	1	3
●	3AK00210	MAIN MIDDLE SW ASS'Y	1	1	1	3
●	3AK00220	EJECT PULLEY ASS'Y	4	4	4	1
●	3AK00310	DISPOSAL TANK ASS'Y	1	1	1	2
●	3AK01030	MIDDLE SENSOR ASS'Y	1	1	1	7
●	3AK02041	BASE,FINISHER	1	1	1	2
●	3AK02060	STAY,PARTITION	2	2	2	2
●	3AK02070	STAY,MIDDLE TRAY	1	1	1	2
●	3AK02080	PULLEY,FINISHER	2	2	2	2
●	3AK02101	REINFORCEMENT,REAR COVER	1	1	1	2
●	3AK02130	MOUNT,RELEASE LEVER	1	1	1	2
●	3AK02140	GUIDE,FINISHER RELEASE	2	2	2	2
●	3AK02150	SHAFT,HOOK RELEASE	1	1	1	2
●	3AK02160	HOOK,FINISHER RELEASE	2	2	2	2
●	3AK02170	WORK PLATE,HOOK RELEASE	1	1	1	2
●	3AK02180	JUNCTION PLATE,RELEASE LEVER	1	1	1	2
●	3AK02191	FRONT MOUNT,SAFETY SWITCH	1	1	1	10
●	3AK02210	PLATE SPRING,HOOK RELEASE	2	2	2	2
●	3AK02220	SHAFT,BASE PULLEY	2	2	2	2
●	3AK02230	SPONGE,BASE	2	2	2	2
●	3AK02240	PULLEY,SORTER	1	1	1	2
●	3AK02250	SHAFT,CONVEYING SUPPORT PLATE	1	1	1	2
●	3AK04100	FRONT HINGE,COVER	1	1	1	1
●	3AK04110	UPPER FULCRUM PLATE,FRONT COVER	1	1	1	1
●	3AK04120	UNDER FULCRUM PLATE,FRONT COVER	1	1	1	1
●	3AK04150	FRONT BASE,MAGNET	1	1	1	1
●	3AK04160	GUIDE,FRONT COVER	1	1	1	1
●	3AK04540	TOP COVER,RELEASE(KM)	1	1	1	1
●	3AK04570	FRONT LID, TOP COVER(KM)	1	1	1	1
●	3AK04580	REAR LID, TOP COVER(KM)	1	1	1	1
●	3AK05030	LABEL,PUNCH DISPOSAL	1	1	1	2
●	3AK05040	LABEL,MIDDLE TRAY	1	1	1	7
●	3AK05050	LABEL,FEED SHIFT GUIDE	2	2	2	5
●	3AK05080	LABEL,TRAILING EDGE STANDARD		1	1	4
●	3AK05090	LABEL B,MIDDLE TRAY	1	1	1	6
●	3AK05510	TOP LABEL,COVER(KM)	4	4	4	1
●	3AK06010	ROLLER,EJECT MAIN	1	1	1	3
●	3AK06020	UPPER GUIDE,MAIN EJECT	1	1	1	4

• Parts with "●" indicates the Service parts.

SP	Part. No.	Description	Quantity			Fig. No.
			120V	230V	240V	
	3AK06040	SHAFT,MAIN EJECT PULLEY	1	1	1	4
	3AK06120	SPRING,MAIN EJECT	2	2	2	4
	3AK06160	MOUNT,MAIN EJECT PRESSURE	1	1	1	4
	3AK06172	TURN PLATE,MAIN EJECT PRESSURE	1	1	1	4
	3AK06180	HOLDER,MAIN EJECT PRESSURE	1	1	1	4
	3AK07010	TRAY,MIDDLE	1	1	1	6
	3AK07021	MOUNT,MIDDLE SLIDER	2	2	2	6
	3AK07050	RACK,MIDDLE	2	2	2	6
	3AK07060	MOUNT,CURSOR	1	1	1	6
	3AK07070	SHAFT,MIDDLE GUIDE	1	1	1	6
●	3AK07080	GEAR,CURSOR MOTOR	2	2	2	6
	3AK07090	MOUNT,MIDDLE PI	4	4	4	6,10
	3AK07100	MOUNT,STAPLER	1	1	1	7
	3AK07110	FRONT RETAINER,STAPLER	1	1	1	7
	3AK07120	REAR RETAINER,STAPLER	1	1	1	7
	3AK07130	GUIDE,STAPLER WIRE	1	1	1	7
	3AK07140	FRONT SUPPORT PLATE,STAPLER	1	1	1	7
●	3AK07150	BELT,MIDDLE CONVEYING	1	1	1	6
	3AK07160	MOVING PLATE,MIDDLE CONVEYING	2	2	2	6
	3AK07200	SHAFT,MIDDLE IDLE	1	1	1	6
	3AK07220	SHAFT,MIDDLE TENSION	2	2	2	6
●	3AK07230	PULLEY 20S3M	4	4	4	6
	3AK07240	MOUNT,MIDDLE BELT SW	1	1	1	6
	3AK07250	LEVER,MIDDLE BELT SW	1	1	1	6
	3AK07300	RETAINER,MIDDLE TRAY	1	1	1	2
	3AK07310	RETAINER,CURSOR MOTOR	2	2	2	6
	3AK07320	SPRING,STAPLER ROTATING	1	1	1	7
	3AK07330	COLLAR,PULLEY RETAINING	1	1	1	6
	3AK07340	GUIDE,SUPPORT PLATE STAPLER	1	1	1	7
	3AK07350	SLIDER,MIDDLE	2	2	2	2
	3AK07360	CUSHION,CURSOR	2	2	2	6
	3AK08012	FRONT FRAME,FEED SHIFT(METRIC)		1	1	5
	3AK08021	REAR FRAME,FEED SHIFT(METRIC)		1	1	5
	3AK08070	PLATE SPRING,FEED SHIFT PULLEY(MET)		1	1	5
	3AK08081	FRONT FRAME,FEED SHIFT(INCH)	1			5
	3AK08090	REAR FRAME,FEED SHIFT(INCH)	1			5
	3AK08130	PLATE SPRING,FEED SHIFT PULLEY(INC)	1			5
	3AK08150	UPPER SHAFT,FEED SHIFT	4	4	4	5
	3AK08160	PLATE SPRING,FEED SHIFT PULLEY	1			5
	3AK08170	REINFORCEMENT,FEED SHIFT GUIDE	1	1	1	5

SP	Part. No.	Description	Quantity			Fig. No.
			120V	230V	240V	
	3AK08183	GUIDE,FEED SHIFT SUB	1	1	1	5
	3AK08201	MOUNT,FEED SHIFT SOLENOID	3	3	3	5
	3AK08210	TENSION PLATE,FEED SHIFT	1	1	1	5
●	3AK08220	GEAR 22,FEED SHIFT	1	1	1	8
●	3AK08230	PULLEY 20,COUPLING	7	7	7	4,5,8
	3AK08251	MOUNT,SOLENOID TURN	1	1	1	9
●	3AK08320	UPPER BELT,FEED SHIFT(METRIC)		1	1	5
●	3AK08330	UPPER BELT,FEED SHIFT(INCH)	1			5
●	3AK08340	LOWER BELT,FEED SHIFT(METRIC)		1	1	8
●	3AK08350	LOWER BELT,FEED SHIFT(INCH)	1			8
	3AK08371	MAGNET,FEED SHIFT	2	2	2	5
	3AK08380	PLATE SPRING,FEED SHIFT PULLEY(MET)		1	1	5
	3AK08390	BASE,MAGNET FEED SHIFT	1	1	1	5
	3AK08420	SEAL,MAGNET FEED SHIFT	2	2	2	5
	3AK08430	SPACER,TURN	1	1	1	5
	3AK08451	PLATE SPRING,GROUND WIRE FEED SHIF	1	1	1	5
	3AK08480	CUSHION,FEED SHIFT GUIDE	13	13	13	3,5,9
	3AK08490	FRONT FILM,PAPER EDGE GUIDE	1	1	1	5
	3AK08500	REAR FILM,PAPER EDGE GUIDE	1	1	1	5
	3AK08560	FILM,PLATE SPRING GUIDE FILM	1			5
	3AK08570	LID,MAGNET	2	2	2	5
	3AK12330	TANK,DISPOSAL	1	1	1	2
	3AK12340	MOUNT,DISPOSAL TANK	2	2	2	2
●	3AK16010	ROLLER,EJECT SUB	1	1	1	4
●	3AK16030	PULLEY,CONVEYING	1	1	1	4
	3AK16101	GUIDE,CONVEYING	1	1	1	4
	3AK16110	UPPER SEPARATION CLAW,CONVEYING	1	1	1	4
	3AK16120	LOWER CLAW,CONVEYING	1	1	1	4
	3AK16130	UPPER LEVER,CONVEYING	1	1	1	4
	3AK16140	LOWER LEVER,CONVEYING	1	1	1	4
	3AK16150	MOUNT,CONVEYING SOLENOID	1	1	1	4
	3AK16220	GUIDE,EJECT	1	1	1	1
●	3AK16240	TORQUE LIMITER,MIDDLE DRIVE	1	1	1	4
	3AK16251	REINFORCEMENT,CONVEYING GUIDE	1	1	1	4
	3AK16261	SHEET,EJECT	4	4	4	1
	3AK16270	PLATE SPRING,EJECT GROUND	1	1	1	1
	3AK20010	RAIL,MAIN TRAY	2	2	2	2
	3AK20020	FRONT FRAME,MAIN TRAY	1	1	1	3
	3AK20030	REAR FRAME,MAIN TRAY	1	1	1	3
	3AK20040	SUPPORT PLATE,MAIN TRAY	1	1	1	3

• Parts with "●" indicates the Service parts.

SP	Part. No.	Description	Quantity			Fig. No.
			120V	230V	240V	
	3AK20050	HOLDER,TIMING BELT	2	2	2	3
	3AK20060	TENSION PLATE,MAIN TRAY	2	2	2	3
	3AK20070	SHAFT,MAIN TRAY DRIVE	1	1	1	3
●	3AK20080	GEAR 18/50	1	1	1	3
●	3AK20090	GEAR 51	1	1	1	3
	3AK20100	MOUNT,MAIN TRAY DRIVE	1	1	1	3
	3AK20110	SHAFT,WORM	1	1	1	3
	3AK20120	SHAFT 18/50	1	1	1	3
●	3AK20130	GEAR,WORM MAIN TRAY	1	1	1	3
	3AK20140	DETECTION PLATE,MAIN TRAY	1	1	1	3
	3AK20150	DETECTION PLATE,MAIN TRAY SENSOR M	1	1	1	3
	3AK20160	MOUNT,MAIN TRAY SENSOR MIDDLE	1	1	1	3
	3AK20170	FILM,MAIN TRAY SENSOR	1	1	1	3
	3AK20180	PIN,MAIN TRAY	4	4	4	3
	3AK20190	MOUNT BASE,TRAY DETECTION SENSOR	2	2	2	10
	3AK20200	PULLEY,MAIN TRAY	4	4	4	3
●	3AK20210	BELT,TRAY LIFT	2	2	2	3
●	3AK20220	BELT,TRAY DRIVE	1	1	1	3
●	3AK20230	PULLEY 20S5M	4	4	4	3
●	3AK20240	VIBRATION INSULATOR,MAIN TRAY	3	3	3	13
	3AK20250	SPRING,MAIN TRAY SENSOR MIDDLE	1	1	1	3
●	3AK22020	PULLEY 14,IDLE	1	1	1	8
●	3AK22030	GEAR 29,IDLE	1	1	1	8
●	3AK22040	PULLEY 40,FEED IN	2	2	2	4,8
●	3AK22060	GEAR 33,THRUST	1	1	1	8
●	3AK22070	GEAR 45,MOTOR IDLE	1	1	1	8
●	3AK22080	TORQUE LIMITER,MIDDLE DRIVE	1	1	1	8
	3AK22100	SHAFT,IDLE JOINT	1	1	1	8
●	3AK22140	GEAR 40,MIDDLE DRIVE	1	1	1	8
	3AK22190	SUPPORT PLATE,IDLE JOINT	1	1	1	8
	3AK22200	PIN,DRIVE SHIFT	1	1	1	8
●	3AK22290	COLLAR 22,DRIVE SHIFT	1	1	1	8
	3AK22300	PIN,IDLE FEED SHIFT	1	1	1	8
	3AK22320	TURN PLATE,DRIVE SHIFT	1	1	1	8
	3AK22330	LEVER,DRIVE SHIFT	1	1	1	8
	3AK22340	MOUNT,SOLENOID SHIFT	1	1	1	8
	3AK22370	PLATE SPRING,DRIVE GROUND	1	1	1	8
●	3AK22390	COLLAR 27,DRIVE SHIFT	1	1	1	8
●	3AK22410	COLLAR 13,DRIVE SHIFT	1	1	1	8
	3AK26020	MOUNT,SIGNAL WIRE	1	1	1	10

SP	Part. No.	Description	Quantity			Fig. No.
			120V	230V	240V	
	3AK26030	MOUNT,WIRE	2	2	2	10
●	3AK27010	MOTOR,MAIN TRAY	1	1	1	3
●	3AK27030	SWITCH,SET	1	1	1	10
●	3AK27040	SOLENOID,PADDLE	3	3	3	5
●	3AK27050	STAPLER	2	2	2	7
	3AK27510	WIRE,MIDDLE TRAY	1	1	1	7
	3AK27521	WIRE,INTERFACE	1	1	1	10
	3AK27540	JUNCTION WIRING,PADDLE SOLENOID	1	1	1	5
	3AK27560	JUNCTION WIRING,PAPER REGISTRATION	1	1	1	5
●	3AK27580	SOLENOID,DRIVE SWITCH	1	1	1	8
●	3AK28020	REAR STACK SENSOR PCB	1	1	1	10
●	3AK28030	FRONT STACK SENSOR PCB	1	1	1	10
●	3AK68010	CARTRIDGE,STAPLER	2	2	2	13
●	3AK68030	UPPER CONVEYING PULLEY ASS'Y	2	2	2	1
●	3AK68040	LOWER CONVEYING PULLEY ASS'Y	2	2	2	4
●	3AX22030	JOINT,TORQUE LIMITER	2	2	2	8,12
	3BD00100	MAIN DRIVE ASS'Y	1	1	1	8
	3BD02042	MOUNT,SLIDER	1	1	1	2
	3BD02050	MOVING PLATE,PULLEY SORTER	1	1	1	2
	3BD02060	SHAFT,CASTER	1	1	1	2
	3BD04010	RIGHT VIBRATION INSULATOR,BASE	1	1	1	2
●	3BD04030	TOP VIBRATION INSULATOR B,COVER	1	1	1	1
	3BD04050	TOP SHEET,RELEASE	2	2	2	1
	3BD06040	SPRING B,MAIN EJECT PRESSURE	2	2	2	4
	3BD07010	MOUNT,MIDDLE DRIVE	1	1	1	6
	3BD07020	SHAFT,MIDDLE DRIVE	1	1	1	6
●	3BD07030	GEAR 24/33,IDLE	1	1	1	6
	3BD07040	GUIDE,MOVING PLATE	1	1	1	6
●	3BD07050	CLUTCH,MIDDLE TRAY	2	2	2	6,9
	3BD07060	TENSION PLATE,MIDDLE CONVEYING	2	2	2	6
●	3BD07080	PULLEY 22,MIDDLE TRAY IDLE	2	2	2	6
●	3BD08040	ROLLER B,FEED SHIFT	1	1	1	5
●	3BD08050	PULLEY,FEED SHIFT	12	12	12	5
	3BD08060	LEVER,FEED SHIFT SOLENOID	3	3	3	5
	3BD08070	LOWER REINFORCEMENT,FEED SHIFT GUI	1	1	1	5
●	3BD16050	LEFT SHEET A,FEED IN	1	1	1	4
●	3BD16060	LEFT SHEET B,FEED IN	1	1	1	4
	3BD22010	RETAINER,MAIN DRIVE	1	1	1	8
●	3BD22030	PULLEY 37/48,DRIVE	1	1	1	8
●	3BD22040	PULLEY 31,CONVEYING ROLLER	1	1	1	4

• Parts with "●" indicates the Service parts.

SP	Part. No.	Description	Quantity			Fig. No.
			120V	230V	240V	
●	3BD22060	PULLEY 22,COUPLING	1	1	1	8
	3BD22080	SHAFT,MAIN DRIVE	1	1	1	8
●	3BD22110	BELT,PUNCH DRIVE	1	1	1	8
	3BD22120	SHAFT 40/21,IDLE	1	1	1	8
	3BD22130	PIN,PADDLE CLUTCH(M4)	1	1	1	8
	3BD22150	JOINT,TORQUE LIMITER	1	1	1	8
●	3BD22160	TORQUE LIMITER,DRIVE	1	1	1	8
●	3BD22180	BELT,EJECT DRIVE	2	2	2	4,8
	3BD22200	TENSION PLATE C,DRIVE	1	1	1	8
	3BD22210	MOUNT,PADDLE IDLE	1	1	1	8
●	3BD22220	GEAR 31,FEED SHIFT DRIVE	1	1	1	8
●	3BD22230	GEAR 42,PADDLE INPUT	1	1	1	8
●	3BD22240	GEAR 20/22,PADDLE IDLE	1	1	1	8
●	3BD22250	GEAR 17,FEED SHIFT ROLLER	1	1	1	5
●	3BD27010	MOTOR,MAIN	1	1	1	8
●	3BD68020	ROLLER FEED IN ASS'Y SP	1	1	1	4
	3B622040	COLLAR 21	1	1	1	8
	3CD00030	TOP COVER ASS'Y	1	1	1	1
	3CD02010	RETAINER,FINISHER	1	1	1	13
●	3CG01011	MAIN PCB ASS'Y	1	1	1	10
●	3CG05070	LABEL,OPERATION PAPER SET(USA)	1			1
●	3CG05080	LABEL,OPERATION PAPER SET(EUR)		1	1	1
●	3CG27011	IC,ROM	1	1	1	10
	3CG82010	SET,DECURLER COPY	1	1	1	14
	3C100010	BASE ASS'Y	1	1	1	2
	3C100020	FRONT FRAME ASS'Y	1	1	1	2
	3C100030	REAR FRAME ASS'Y	1	1	1	2
●	3C100040	PUNCH ASS'Y(METRIC)		1	1	4
●	3C100050	PUNCH ASS'Y(INCH)	1			4
	3C100070	MIDDLE TRAY ASS'Y	2	2	2	6,7
	3C100083	UPPER GUIDE FEED SHIFT ASS'Y(METRI		1	1	5
	3C100091	UPPER GUIDE FEED SHIFT ASS'Y(INCH)	1			5
	3C100101	FEED SHIFT UNIT ASS'Y(METRIC)		1	1	5
	3C100110	FEED SHIFT UNIT ASS'Y(INCH)	1			5
	3C100120	HOLDER MAIN EJECT ASS'Y	1	1	1	3
	3C100130	DRIVE UNIT ASS'Y	1	1	1	8
	3C100140	PUNCH DRIVE ASS'Y	1	1	1	8
	3C100150	IDLE ASS'Y	1	1	1	8
	3C100160	CONVEYING PULLEY ASS'Y	1	1	1	4
	3C100181	FRONT COVER ASS'Y	1	1	1	1

SP	Part. No.	Description	Quantity			Fig. No.
			120V	230V	240V	
	3C100191	TRAY SET ASS'Y	1	1	1	13
	3C100200	RELEASE LEVER ASS'Y	1	1	1	2
	3C100212	STAY LEADING FEED ASS'Y	1	1	1	9
	3C100231	LOWER GUIDE CONVEYING ASS'Y	1	1	1	4
	3C100240	TENSION PLATE FEED SHIFT DRIVE ASS	1	1	1	8
	3C100250	CONVEYING SOLENOID ASS'Y	1	1	1	4
	3C101020	INTERFACE WIRE ASS'Y	1	1	1	10
	3C102010	FRONT FRAME	1	1	1	2
	3C102020	REAR FRAME	1	1	1	2
	3C102030	PARTITION,FINISHER	1	1	1	2
	3C102040	STAY,FEED IN	1	1	1	2
	3C102070	SLIDER,FINISHER	2	2	2	2
	3C102090	REINFORCEMENT,FINISHER SORTER	1	1	1	1
●	3C104011	FRONT COVER	1	1	1	1
●	3C104020	REAR COVER	1	1	1	1
●	3C104030	TOP COVER	1	1	1	1
	3C104040	FULCRUM PLATE, TOP COVER	2	2	2	1
	3C104050	TOP GROUND PLATE,COVER	1	1	1	1
	3C104060	RIGHT COVER	1	1	1	1
●	3C104071	TRAY,MAIN	1	1	1	13
●	3C104080	TRAY,SUB	1	1	1	13
	3C104090	LEVER,RELEASE	1	1	1	2
●	3C104100	TOP HINGE,COVER	2	2	2	1
●	3C105020	LABEL,JAM REMOVED	1	1	1	1
	3C106010	HOLDER,MAIN EJECT	3	3	3	3
	3C106020	MOUNT,MAIN EJECT PI	1	1	1	3
	3C106030	STAY,MAIN EJECT	1	1	1	3
	3C106040	LEVER,HOLDER MAIN EJECT	1	1	1	3
	3C106050	SHAFT,HOLDER MAIN EJECT	1	1	1	3
	3C106060	SPRING,HOLDER MAIN EJECT PULL	1	1	1	3
	3C106070	SPRING,HOLDER MAIN EJECT RESET	1	1	1	3
	3C106080	LOWER GUIDE,MAIN EJECT	1	1	1	3
	3C106090	TENSION PLATE,LEADING REGISTRATION	1	1	1	4
●	3C106100	PULLEY 28, SORT EJECT	1	1	1	3
	3C106110	FILM,MAIN EJECT(INCH)	1			4
	3C106120	FILM,MAIN EJECT(METRIC)		1	1	4
	3C107010	BASE,MIDDLE TRAY	1	1	1	7
	3C107020	FRONT GUIDE,PAPER HOLDER	1	1	1	7
	3C107030	REAR GUIDE,PAPER HOLDER	1	1	1	7
	3C107040	SUPPORT PLATE,PAPER HOLDER	2	2	2	7

• Parts with "●" indicates the Service parts.

SP	Part. No.	Description	Quantity			Fig. No.
			120V	230V	240V	
	3C107050	REINFORCEMENT,PAPER HOLDER	1	1	1	7
	3C107060	WEIGHT,PAPER GUIDE	1	1	1	7
	3C107070	SPONGE,PAPER HOLDER	2	2	2	7
	3C107080	FRONT CURSOR,MIDDLE	1	1	1	6
	3C107090	REAR CURSOR,MIDDLE	1	1	1	6
	3C107100	MOUNT,PULSE DISC	1	1	1	7
	3C107110	MOUNT,PI	1	1	1	7
	3C107120	SHAFT,PULSE DISC	1	1	1	7
	3C107130	REAR WEIGHT,PAPER GUIDE	1	1	1	7
	3C107140	GUIDE,STACK	2	2	2	7
	3C108010	UPPER GUIDE,FEED SHIFT(INCH)	1			5
	3C108020	UPPER GUIDE,FEED SHIFT(METRIC)		1	1	5
●	3C108030	ROLLER A1,FEED SHIFT	2	1	1	5
●	3C108040	ROLLER B1,FEED SHIFT	1	2	2	5
	3C108050	GUIDE 11,FEED SHIFT	1			5
	3C108060	GUIDE 14,FEED SHIFT	1			5
	3C108070	GUIDE 17,FEED SHIFT	1			5
	3C108080	GUIDE A3,FEED SHIFT		1	1	5
	3C108090	GUIDE B4,FEED SHIFT		1	1	5
	3C108100	GUIDE A4R,FEED SHIFT		1	1	5
●	3C108110	PULLEY,LEADING FEED	2	2	2	9
	3C108120	LOWER SHAFT,LEADING FEED	1	1	1	9
	3C108130	HOLDER,TORQUE LIMITER	1	1	1	9
	3C108140	UPPER SHAFT,LEADING FEED	1	1	1	9
	3C108150	TURN PLATE,LEADING FEED	1	1	1	9
	3C108160	MOUNT,TURN LEVER	1	1	1	9
	3C108170	UPPER LEVER,TURN	1	1	1	9
	3C108180	STAY,LEADING FEED	1	1	1	9
	3C108190	FRONT GUIDE,LEADING FEED	1	1	1	9
	3C108200	REAR GUIDE,LEADING FEED	1	1	1	9
	3C108210	UPPER TURN PLATE	1	1	1	5
	3C108220	STOPPER,TURN	1	1	1	5
	3C108240	LOWER SPRING,TURN	1	1	1	9
	3C108250	ADJUSTING PLATE,TURN	1	1	1	9
	3C108260	COLLAR,TURN SPRING	1	1	1	9
	3C108290	SPRING,TURN SOLENOID	2	2	2	3,9
	3C108300	UPPER CUSHION,TURN	4	4	4	5,9
	3C108310	HOLDER,PAPER(METRIC)		2	2	
	3C108320	LEVER,HOLDER	1	1	1	9
	3C108330	SHAFT,HOLDER	1	1	1	9

SP	Part. No.	Description	Quantity			Fig. No.
			120V	230V	240V	
	3C108350	MOUNT,HOLDER SOLENOID	1	1	1	9
	3C108360	SPRING,HOLDER SOLENOID	1	1	1	9
	3C108370	SPRING,HOLDER LEVER	1	1	1	9
	3C108380	HOLDER,PAPER(INCH)	2			9
	3C108400	FILM,LEADING FEED DRIVE	1	1	1	9
	3C108410	HOLDER,FEED SHIFT PULLEY		1	1	5
	3C112010	UNIT,PUNCH(METRIC)		1	1	4
	3C112020	UNIT,PUNCH(INCH)	1			4
	3C112040	GUIDE,DISPOSAL TANK	1	1	1	2
●	3C116010	ROLLER,DECURLER PRESSURE	2	2	2	12
	3C116020	LEFT ROLLER,DECURLER	1	1	1	12
	3C116030	RIGHT ROLLER,DECURLER	1	1	1	12
	3C116040	UPPER GUIDE,CONVEYING	1	1	1	1
	3C116050	LOWER GUIDE,CONVEYING	1	1	1	4
	3C116060	FRONT GUIDE,CONVEYING	1	1	1	12
	3C116070	UPPER GUIDE,FEED IN	1	1	1	4
	3C116080	LOWER GUIDE,FEED IN	1	1	1	4
	3C116090	SHAFT,DECURLER PRESSURE	2	2	2	12
	3C116100	CAM,DECURLER	4	4	4	12
	3C116110	MOUNT,DECURLER ADJUSTMENT	4	4	4	12
	3C116120	LEVER,DECURLER PRESSURE	2	2	2	12
	3C116130	LEVER,PRESSING PLATE	1	1	1	12
	3C116140	KNOB,DECURLER	1	1	1	12
	3C116150	LEFT GUIDE,CONVEYING	1	1	1	4
	3C116160	UPPER LEVER,PRESSING PLATE	1	1	1	12
	3C122010	SUPPORT PLATE,DRIVE	1	1	1	8
●	3C122020	BELT 378,DRIVE	1	1	1	8
●	3C122030	BELT 552,FEED SHIFT DRIVE	1	1	1	8
	3C122040	SHAFT,CONVEYING PULLEY	1	1	1	4
	3C122050	MOUNT,DECURLER DRIVE	1	1	1	12
	3C122060	SHAFT,DECURLER DRIVE	1	1	1	12
●	3C122070	GEAR 34,DECURLER	1	1	1	12
●	3C122080	GEAR 27,DECURLER	1	1	1	12
	3C122090	TENSION PLATE A,FEED SHIFT DRIVE	1	1	1	8
	3C122100	SUPPORT PLATE,IDLE PUNCH	1	1	1	8
	3C122110	SHAFT 14/29,IDLE	1	1	1	8
	3C122120	SHAFT 45/28/40/30,IDLE	1	1	1	8
●	3C122130	COLLAR L,PUNCH DRIVE	1	1	1	8
	3C122160	MOUNT,LEADING FEED DRIVE	1	1	1	9
	3C122170	SHAFT,LEADING FEED DRIVE	1	1	1	9

• Parts with "●" indicates the Service parts.



SP	Part. No.	Description	Quantity			Fig. No.
			120V	230V	240V	
●	3C122180	GEAR Z29,LEADING FEED DRIVE	1	1	1	9
	3C122190	TENSION PLATE,LEADING FEED DRIVE	1	1	1	9
	3C122200	SPRING,LEADING FEED DRIVE TENSION	1	1	1	9
●	3C122210	GEAR 27,DRIVE SHIFT	1	1	1	8
	3C126010	MOUNT,MAIN PCB	1	1	1	10
●	3C127010	SOLENOID,EJECT	1	1	1	3
●	3C127030	UPPER SOLENOID,TURN	1	1	1	9
●	3C127040	SOLENOID,LEADING REGISTRATION	1	1	1	9
	3C127500	WIRE,MAIN	1	1	1	11
	3C127510	JUNCTION WIRING,EJECT	1	1	1	10
	3C127520	JUNCTION WIRING,RELEASE SWITCH	1	1	1	10
	3C127531	JUNCTION WIRING,FEED SOLENOID	1	1	1	9
	3C127540	JUNCTION WIRING,EJECT SENSOR	1	1	1	3
	3C127550	JUNCTION WIRING,EJECT SOLENOID	1	1	1	3
	3C127560	LOWER JUNCTION WIRING,CONVEYING SE	1	1	1	5
	3C127570	UPPER JUNCTION WIRING,CONVEYING SE	1	1	1	4
	3C127600	JUNCTION WIRING,INTERFACE	1	1	1	10
	33406500	HANDLE,REGISTRATION	1	1	1	6
	33420250	SPRING,FIXING CLAW	1	1	1	4
●	33906070	TORQUE LIMITER,PAPER FEED	2	2	2	4,8
●	33906430	TORQUE LIMITER,BYPASS	2	2	2	9,12
	33906880	STOPPER,BYPASS TABLE	2	2	2	1
	33920500	RETAINING PIN,FIXING GUIDE	1	1	1	13
●	34806140	STOPPER 4	5	5	5	3,4,9
●	34806150	STOPPER 5	19	20	20	4,5,9
●	34827020	SWITCH,REGISTRATION	1	1	1	3
●	34922280	PULLEY 30	1	1	1	8
●	34922570	GEAR 23,DEVELOPING	1	1	1	8
●	35327400	SWITCH,FEED	7	7	7	3,6,10
	35912480	SPRING,SCANNER WIRE	1	1	1	8
●	36714130	GEAR 27,DEVELOPING	1	1	1	8
	36802270	REINFORCEMENT,RELEASE LEVER	1	1	1	2
●	36827140	SWITCH A,INTERLOCK	2	2	2	10
	36882040	SET STAPLE CARTRIDGE	2	2	2	13
●	36993200	PARTS,CLUTCH PAPER FEED,SP	1	1	1	8
	48127502	PIN,SEPARATION PULLEY	2	2	2	2,4
	48128609	PIN,UPPER FRONT COVER	2	2	2	2
	48128807	PIN,FRAME	3	3	3	2,7
	48529303	SPRING,TENSION	2	2	2	4,8
●	48928800	PULLEY,TIMING BELT	6	7	7	4,5,8,9

SP	Part. No.	Description	Quantity			Fig. No.
			120V	230V	240V	
	49021100	BUSHING	5	5	5	3
	49028101	BUSH 8	1	1	1	3
●	49028112	BUSHING 8,LOWER REG.ROLLER	1	1	1	6
	60116080	PIN RAIL DEV.	5	5	5	4,8
	60804120	MAGNET CATCH	3	3	3	6,7,10
	60912270	BEARING,688ZZ	1	1	1	9
●	61715510	PULLEY,SHUTTER	2	2	2	9
	61716110	SPRING,CLEANING DRIVE TENSION	1	1	1	9
●	62221110	PULLEY,FEEDBACK	2	2	2	4
●	62227070	SOLENOID B,FEED SHIFT	2	2	2	4
	63202120	SUPPORT PLATE,COVER	2	2	2	4
●	63212210	STATIC ELIMINATOR,EJECT	2	2	2	1,4
●	63213261	PAD, EJECT ORIGINAL HOLDER	6	6	6	3
	63213300	RETAINER,EJECT ORIGINAL HOLDER	6	6	6	3
	63213320	CUSHION,ORIGINAL COLLECTION	5	5	5	3,4
●	63227020	SWITCH,FEED	1	1	1	10
●	63227150	SWITCH L,FEED	2	2	2	4,5
●	63416200	PULLEY 34,CONVEYING	1	1	1	3
	63511091	SPRING,ADF HOOK	1	1	1	8
●	63511220	STOP RING,4	3	3	3	6,7
	63527200	GROUND WIRE,STATIC ELIMINATOR	1	1	1	1
	63568070	GROUND WIRE,FEED ROLLER	1	1	1	5
	63822350	SPRING,JOINT	1	1	1	6
●	65016080	STOP RING E3	6	6	6	4,6,14
	65710370	SPRING,ORIGINAL DETECTION HOLDER	1	1	1	7
	65926530	SPRING,SAFETY SWITCH	2	2	2	1
●	66220160	STATIC ELIMINATOR,PRESSURE ROLLER	1	1	1	4
●	67322050	GEAR 45 DEVELOPING DRIVE	1	1	1	4
●	67322230	BUSHING 8	4	4	4	4,6,8
●	68322210	PULLEY,21 IDLE	1	1	1	8
●	68822330	BEARING,DRIVE	7	7	7	9,14
●	69914030	GEAR,MAGNET ROLLER	1	1	1	8
	71807040	BUSHING 8,PF	1	1	1	8
	71821221	PIN,LOOP GUIDE	1	1	1	8
	72602220	PIN,HANDLE	2	2	2	12
●	72622141	TENSION PULLEY 20	1	1	1	8
	72914140	REAR BUSHING,TONER RECYCLE	2	2	2	4
	72918050	PIN,BLADE ARM	2	2	2	8,9
	73202040	RUBBER,SPACER	2	2	2	4
●	73210370	GEAR 18,LOOP	1	1	1	9

• Parts with "●" indicates the Service parts.

SP	Part. No.	Description	Quantity			Fig. No.
			120V	230V	240V	
	73210450	BUSH, 6	6	6	6	3,4,9
	73226040	SPRING, REVERSE SOLENOID	4	4	4	4,5
	73818100	SPRING, BLADE THRUST	1	1	1	8
	73918080	PIN, CLEANING BLADE	3	3	3	7,9
●	73920270	STATIC ELIMINATOR, FIXING UNIT	1	1	1	1
	74306880	RATCH, PAPER GUIDE	2	2	2	2
●	74718091	BUSHING CLEANING UNIT	2	2	2	8
●	74808080	BEARING, 686ZZNR	15	15	15	3,8,12
	74808140	BEARING, LNR-1360ZZR	2	2	2	9
●	75122090	GEAR, FRONT	1	1	1	9
●	75207370	GEAR16 ORIGINAL FEEDBACK	1	1	1	12
	75402210	CUSHION STAY	2	2	2	1
●	75416230	STATIC ELIMINATOR SORT BIN	1	1	1	4
	75914020	RELEASE SPRING MAIN DEVELOPING UNI	2	2	2	5
●	76514080	BUSHING 6 DRIVE	4	4	4	3,5,9
	78710370	CUSHION UPPER LOOP	3	3	3	1,6
●	78727110	JAM DETECTION SWITCH	1	1	1	6
	78918290	FLANGE PULLEY 27	1	1	1	3
	B4104080	TRIPLE SCREW M4X08(CHROMIUM)	4	4	4	13
	B4104140	TRIPLE SCREW M4X14(CHROMIUM)	2	2	2	13
	B4304100	TRIPLE SCREW M4X10 (BLACK)	2	2	2	13
	C1054070	DOMED CAP NUT M4(CLASS 2)	1	1	1	13
	C4204000	CROWN WASHER TWM4	2	2	2	13
●	G3163800	BEARING 63800ZZNRMC3	1	1	1	4
	J0080030	RECEPTACLE EI 3P,171822-3	1	1	1	7
	J0080900	SOCKET,170205-1(AMP)	3	3	3	7
	J0150030	RECEPTACLE,175778-3(AMP)	4	4	4	7
	J0150900	CONTACTOR,175161-1(AMP)	12	12	12	7
	J0153030	RECEPTACLE,179228-3(AMP)	5	5	5	11
	J0153900	CONTACTOR,179518-1(AMP)	30	30	30	11
	J0154040	RECEPTACLE,179228-4(AMP)	1	1	1	11
	J0154090	RECEPTACLE,179228-9(AMP)	1	1	1	11
	J0156030	RECEPTACLE,2-179228-3(AMP)	1	1	1	11
	J0200060	PLUG,PHR-6(JST)	2	2	2	7
	J0222900	PIN EL,LLM-01T-1.3E	2	2	2	11
	J0223020	RECEPTACLE EL 2P,ELR-02V	1	1	1	11
	J0240020	PLUG SM 2P,SMP-02V-NC	1	1	1	11
	J0240030	PLUG SM 3P,SMP-03V-NC	1	1	1	11
	J0241020	PLUG SM 2P,SMP-02V-BC	3	3	3	5,7,11
	J0242900	PIN SM,BYP-001T-0.6	3	3	3	5

SP	Part. No.	Description	Quantity			Fig. No.
			120V	230V	240V	
	J0243030	RECEPTACLE SM 3P,SMR-03V-B	1	1	1	5
	J0250900	SOCKET,BHF-001T-0.8SS	4	4	4	5,7
	J0250910	SOCKET NH,BHF-001T-0.8BS	6	6	6	11
	J0272020	RECEPTACLE,VH,2P,VHR-2N	1	1	1	11
	J0272030	VH RECEPTACLE 3P,VHR-3N	1	1	1	11
	J0272900	CONTACTOR,BVH-21T-P1.1(JST)	4	4	4	11
	J0311130	RECEPTACLE,5480-13(MOLEX)	2	2	2	7
	J0311900	SOCKET,5479PBTL	22	22	22	7
	J0421080	SOCKET 8P,DF1B-8DS-2.5RC	1	1	1	7
	J0421900	CONTACTOR,DF1B-2428SC(HIROSE)	8	8	8	7
	J0440200	PLUG,DF11-20DS-2C(HIROSE)	1	1	1	11
	J0440900	PIN,DF11-EP2428PC(HIROSE)	9	9	9	11
	J0441240	RECEPTACLE,DF11-24DS-2C(HIROSE)	1	1	1	11
	J0441900	CONTACTOR,DF11-2428SC	1	1	1	11
	J0443100	PLUG DF11-10DEP-2C(HIROSE)	1	1	1	11
	J0450020	PLUG,DF3-2S-2C(HIROSE)	1	1	1	5
	J0450900	SOCKET,DF3-2428SC(HIROSE)	2	2	2	5
	J0452900	PIN,DF3-EP2428PC(HIROSE)	7	7	7	5
	J0453070	PRUG,DF3-7EP-2C(HIROSE)	1	1	1	5
	J5080120	RECEPTACLE,PHDR-12VS(JST)	1	1	1	7
	J5080160	RECEPTACLE,PHDR-16VS(JST)	1	1	1	11
	J5080200	RECEPTACLE,PHDR-20VS(JST)	1	1	1	11
	J5080240	RECEPTACLE,PHDR-24VS(JST)	1	1	1	11
	J5080260	RECEPTACLE,PHDR-26VS(JST)	1	1	1	11
	J5080320	RECEPTACLE,PHDR-32VS(JST)	1	1	1	7
	J5080900	SOCKET,BPHD-002T-P0.5(JST)	45	45	45	7,11
	M0207000	BINDING BAND,KB-100-1	1	1	1	3
	M1203220	OPEN BUSHING,OCB-625	2	2	2	2,10
	M1203240	OPEN BUSHING,OCB-500	4	4	4	8,10
	M1203510	OPEN BUSHING,OCB-1000	1	1	1	2
	M1203550	STRAIN RELEAF BUSHING,SR-7W-2	1	1	1	10
	M2104100	EDGING CE-012	3	3	3	4,7,8
	M2104200	EDGING EDS-1	5	5	5	2,5,10
	M2104260	EDGING,EDS-0607U(KITAGAWA)	1	1	1	7
	M2104350	EDGING,EDS-0607M(KITAGAWA)	2	2	2	4,10
	M2105210	MINI CLAMP,UAMS-02WL-0(KITAGAWA)	2	2	2	9
	M2105600	CLAMP,LS-10	4	4	4	10
	M2105740	MINIATURE CLAMP,UAMS-05S-2	3	3	3	3
	M2107120	BINDING BAND SG-130	27	27	27	3,5,6,7,10
	M2107200	BAND,SG-110 V0(KITAGAWA)	1	1	1	7

• Parts with "●" indicates the Service parts.

SP	Part. No.	Description	Quantity			Fig. No.
			120V	230V	240V	
	M2109230	WIRE SADDLE,LWS-3S(KITAGAWA)	11	11	11	2,4,8,10
	M2109260	WIRE SADDLE,YMC-05-H-0(KITAGAWA)	6	6	6	2,4,6,7
	M2109350	WIRE SADDLE,YMC-15-0(KITAGAWA)	1	1	1	9
	M2607010	BINDING BAND,PLT1M	25	25	25	5,6,7,11

• Parts with "●" indicates the Service parts.

## CLASSIFICATION OF THE SCREWS IN ILLUSTRATION

<u>REF.</u>	<u>ITEM #</u>	<u>DESCRIPTION</u>	<u>REF.</u>	<u>ITEM #</u>	<u>DESCRIPTION</u>	<u>REF.</u>	<u>ITEM #</u>	<u>DESCRIPTION</u>
APN	B3013120	+PAN HEAD TAP-P TIGHT SCREW M3X12	BHV	B3313060	+BINDING TAP-TIGHT P BRONZE SCREW M3X06	HCL	B4103060	TRIPLE SCREW M3X06(CHROMIUM)
AZA	B0024060	ROUND HEAD SCREW WITH SW.W M4X6	BIC	B8023080	BINDING TAP-TITE B SCREW M3X8	HDA	B4343060	TRIPLE TAP-TITE P SCREW M3X06(BLACK)
AZB	B0024120	ROUND HEAD SCREW WITH SW.W M4X12	BUA	B3314100	BINDING TAP-TITE P BRONZE SCREW M4X10	HDB	B4343080	TRIPLE TAP-TITE P SCREW M3X08(BLACK)
BAA	B1003040	BINDING SCREW,CVM3X4	BVU	B1305160	BINDING SCREW BVM5X16 (BLACK)	HDD	B4344120	TRIPLE TAP-TITE P SCREW M4X12(BLACK)
BAC	B1003080	BINDING SCREW M3X8	DJV	B5393040	W-POINT SET SCREW M3X04	KAK	E0020080	SPRING PIN 2X8
BAL	B1003050	BINDING SCREW CVM3X5	EDB	B9094060	SPECIAL TRUSS HEAD SCREW M4X06	KAM	E0020120	SPRING PIN 2X12
BAN	B1004060	BINDING SCREW CVM4X6	E04	D1000400	STOP RING (E-4)	KAN	E0020140	SPRING PIN 2X14
BAP	B1003100	BINDING SCREW CVM3X10	E05	D1000500	STOP RING (E-5)	KAO	E0020160	SPRING PIN 2X16
BAX	B1004040	BINDING SCREW CVM4X4	E07	D1000700	STOP RING (E-7)	KAX	E0030140	SPRING PIN 3X14
BBB	B1303050	BINDING SCREW BVM3X5 (BLACK)	GEF	B9604060	GROUNDING SCREW M4X6 (BRASS,N;)	KBE	E0120220	SPRING PIN 2X22(SUS)
BBC	B1303100	BINDING SCREW BVM3X10 (BLACK)	HAB	B4003040	TRIPLE SCREW M3X4	KFC	E5120200	SPRING PIN H7A 2X20 SUS
BBD	B1304040	BINDING SCREW BVM4X4 (BLACK)	HAD	B4003050	TRIPLE SCREW M3X05	KKH	E0120200	SPRING PIN 2X20(SUS)
BBE	B1304060	BINDING SCREW BVM4X6 (BLACK)	HAI	B4004060	TRIPLE SCREW M4X06(BLACK)	KKJ	E0025250	SPRING PIN 2.5X25
BBF	B1304080	BINDING SCREW BVM4X8 (BLACK)	HAO	B4043080	TRIPLE TAP-TITE P SCREW M3X08	NAK	C1014000	NUT NSM4
BBP	B1303120	BINDING SCREW BVM3X12 (BLACK)	HAV	B4044080	+TP TAP TIGHT P CHROMATE M4X08	RFH	D5000800	RETAINING RING GTW-8
BBQ	B1300100	BINDING SCREW BVM2.3X10 (BLACK)	HBA	B4303050	TRIPLE SCREW M3X5 (BLACK)	RPU	D4102100	STOP RING CRESCENT 5103-21
BBU	B1303140	BINDING SCREW BVM3X14 (BLACK)	HBB	B4303100	TRIPLE SCREW M3X10 (BLACK)	WAB	C2003080	PLAIN WASHER PWM3
BCK	B1103050	BINDING SCREW CV3X5	HBC	B4304060	TRIPLE SCREW M4X6 (BLACK)	WBB	C2304080	PLAIN WASHER BPWM4-8 (BLACK)
BGF	B1244040	BINDING SCREW WITH LOCK M4X4	HBH	B4303060	TRIPLE SCREW M3X6 (BLACK)	WPB	C2806120	POLYESTER SLIDER WASHER 6.2X12X0.5T
BHB	B3023080	BINDING TAP TIGHT SCREW M3X8	HLB	B4363080	TRIPLE SCREW M3X8 (BLACK), B-TYP.	XAF	C2895110	SHIM 8.2-0.13T
BHF	B3314080	BINDING TAP-TITE P SCREW M4X08	HCA	B4104060	TRIPLE SCREW M4X6(CHROMIUM)	XCF	C2895130	SHIM 8.2-0.5T
BHN	B8013080	BINDING TAP-TIGHT SCREW M3X08	HCF	B4104080	TRIPLE SCREW M4X08(CHROMIUM)	YAA	E9000080	PIN SNAP P8
BHT	B8313060	BINDING TAP-TITE P SCREW M3X06						

**KYOCERA MITA EUROPE B.V.**

Hoeksteen 40, 2132 MS Hoofddorp,  
The Netherlands  
Phone: (020) 6540000  
Home page: <http://www.kyoceramita-europe.com>  
Email: [info@kyoceramita-europe.com](mailto:info@kyoceramita-europe.com)

**KYOCERA MITA NEDERLAND B.V.**

Hoeksteen 40, 2132 MS Hoofddorp,  
The Netherlands  
Phone: (020) 5877200

**KYOCERA MITA (UK) LIMITED**

8 Beacontree Plaza  
Gillette Way,  
Reading RG2 0BS UK  
Phone: (0118) 931 1500

**KYOCERA MITA ITALIA S.P.A.**

Via Verdi 89/91 20063 Cernusco sul Naviglio  
(Milano) Italy  
Phone: 02-92179 1

**S.A. KYOCERA MITA BELGIUM N.V.**

Hermesstraat 8A, 1930 Zaventem, Belgium  
Phone: (02) 7209270

**KYOCERA MITA FRANCE S.A.**

Parc les Algorithmes  
SAINT AUBIN  
91194 GIF-SUR-YVETTE  
France  
Phone: (01) 69852600

**KYOCERA MITA ESPAÑA S.A.**

Edificio Mita, Avda. De Manacor Nº2,  
Urb. Parque Rozas, Apartado de Correos 76,  
28230 Las Rozas, Madrid, Spain  
Phone: (91) 631-8392

**KYOCERA MITA FINLAND OY**

Kirvesmiehenkatu 4, 00810 Helsinki,  
Finland  
Phone: (09) 478-05200

**KYOCERA MITA (SCHWEIZ) AG**

Hölzliwisen, Industriestrasse 28,  
8604 Volketswil, Switzerland  
Phone: (01) 908 4949

**KYOCERA MITA DEUTSCHLAND GMBH**

Mollsfeld 12 40670 Meerbusch,  
Germany  
Phone: 02159-918120

**KYOCERA MITA GMBH AUSTRIA**

Eduard-Kittenberger-Gasse 95,  
1230, Wien, Austria  
Phone: (01) 86338-0

**KYOCERA MITA SVENSKA AB**

Siktgatan 2,  
162 50 Vällingby, Sweden  
Phone: (08) 4719999

**KYOCERA MITA DANMARK A/S**

Industrivej 11, DK-4632 Bjæverskov,  
Denmark  
Phone: 56871100

**KYOCERA MITA PORTUGAL LDA.**

CASCAISTOCK-Armazem nº8,  
Rua das Fiskas, Alcoitão,  
2765 Estoril, Portugal  
Phone: (21) 4602221

**KYOCERA MITA SOUTH AFRICA (PTY) LTD.**

UNIT 3, "Kyalami Crescent,"  
Kyalami Business Park,  
1685 Midrand, South Africa  
Phone: (11) 466-3290

**KYOCERA MITA AMERICA, INC.**

**Headquarters:**  
225 Sand Road, P.O. Box 40008,  
Fairfield, New Jersey 07004-0008,  
U.S.A.  
Phone: (973) 808-8444

**KYOCERA MITA AUSTRALIA PTY. LTD.**

Level 3, 6-10 Talavera Road, North Ryde,  
N.S.W. 2113 Australia  
Phone: (02) 9888-9999

**KYOCERA MITA NEW ZEALAND LTD.**

1-3 Parkhead Place,  
Albany, Auckland,  
New Zealand  
Phone: (09) 415-4517

**KYOCERA MITA (THAILAND) CORP., LTD.**

9/209 Ratchada-Prachachem Road,  
Bang Sue, Bangkok 10800, Thailand  
Phone: (02) 586-0320

**KYOCERA MITA SINGAPORE PTE LTD.**

121 Genting Lane, 3rd Level,  
Singapore 349572  
Phone: (65) 7418733

**KYOCERA MITA HONG KONG LIMITED**

11/F., Mita Centre,  
552-566, Castle Peak Road,  
Tsuen Wan, New Territories,  
Hong Kong  
Phone: (852) 24297422

**KYOCERA MITA CORPORATION**

2-28, 1-chome, Tamatsukuri, Chuo-ku  
Osaka 540-8585, Japan  
Phone: (06) 6764-3555

© 2001 KYOCERA MITA CORPORATION

 is a trademark of Kyocera Corporation

*mita* is a registered trademark of KYOCERA MITA CORPORATION

Printed in Holland