PF-70

———— CONTENTS ————

FIG. 1 COVER	2
FIG. 2 FRAMES	4
FIG. 3 CASSETTE	6
FIG. 4 PAPER FEED-IN SECTION	8
FIG. 5 DRIVING SECTION	10
FIG. 6 ELECTRICAL COMPONENTS	12
• INDEX	14

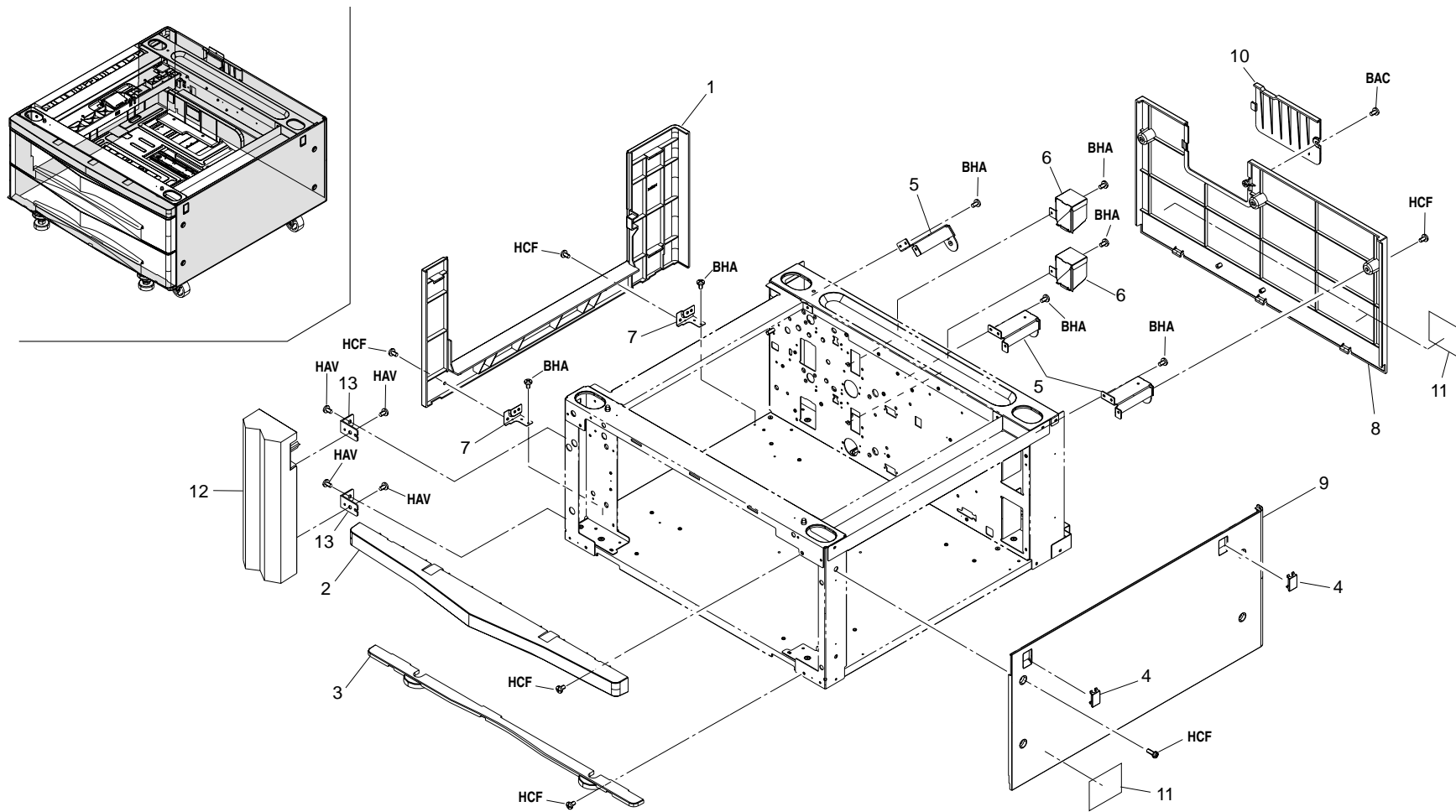

FIG. 1 COVER

3CC

SP	Ref. No.	Part. No.	Description	Quantity		
				120V	230V	240V
●	1	3CF04070	LEFT COVER	1	1	1
●	2	3CF04010	UPPER FRONT COVER	1	1	1
●	3	3CF04020	LOWER FRONT COVER	1	1	1
●	4	3CF04080	LID,COVER	2	2	2
	5	3AT02120	REAR MOUNT,COVER	3	3	3
	6	2AR07720	COVER,CASSETTE RAIL	2	2	2
	7	3AT02110	MOUNT SORTER	2	2	2
●	8	68204120	REAR COVER(K M)	1	1	1
●	9	3CF04100	RIGHT COVER	1	1	1
	10	68204160	COVER,CONNECTOR(K M)	1	1	1
●	11	3AT05070	LABEL,STOPPER	3	3	3
	12	3CF04030	LEFT FRONT COVER	1	1	1
	13	3CF04040	LEFT FRONT MOUNT,COVER	2	2	2

- Parts with "●" are component parts or sub-assemblies of the assembly appearing immediately above them.
- Parts with "●" indicates the Service parts.

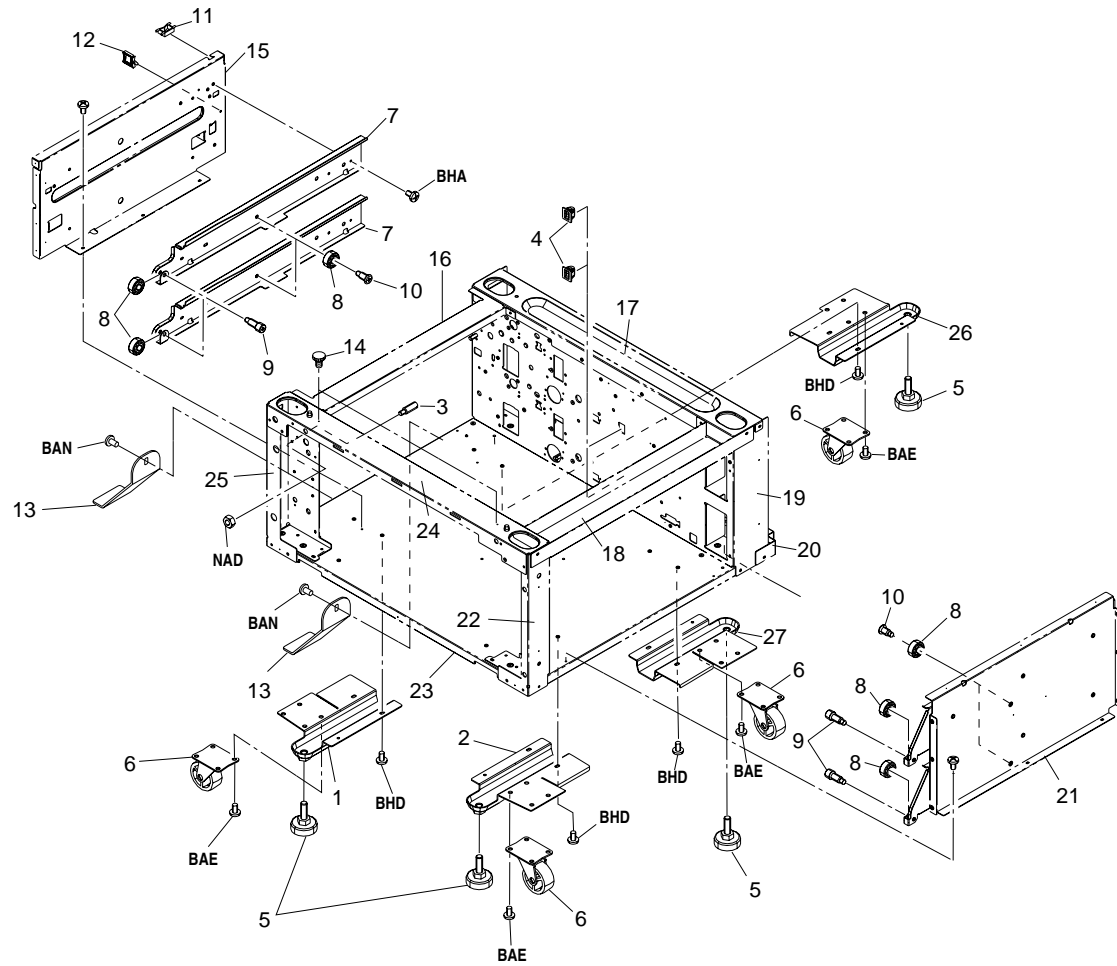
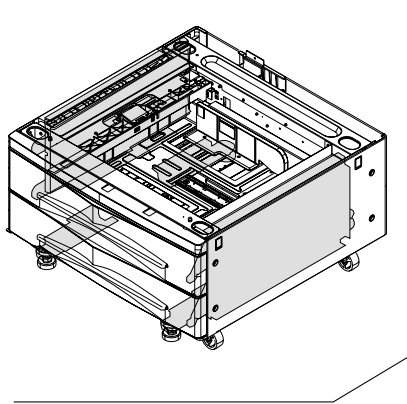

FIG. 2 FRAMES

3CC

SP	Ref. No.	Part. No.	Description	Quantity		
				120V	230V	240V
	1	3AT02092	MOUNT A LEVEL BOLT	1	1	1
	2	3AT02101	MOUNT B LEVEL BOLT	1	1	1
	3	3AT02130	FRONT PIN HOOK	1	1	1
	4	77906291	HOLDER,CASSETTE STOPPER	2	2	2
	5	66502120	BOLT,LEVEL	4	4	4
	6	36502600	CASTER,MACHINE	4	4	4
	7	2AR07140	LEFT RAIL,CASSETTE	2	2	2
●	8	2AR07800	PULLEY,CASSETTE RAIL	8	8	8
	9	2AR07810	FRONT PIN,CASSETTE RAIL	4	4	4
	10	2AR07820	REAR PIN,CASSETTE RAIL	4	4	4
	11	M2104350	EDGING,EDS-0607M(KITAGAWA)	1	1	1
	12	M2109330	WIRE SADDLE,YMC-10-0(KITAGAWA)	1	1	1
	13	3AT02250	FULCURUM PLATE	2	2	2
	14	64007010	PIN,CLEANER	2	2	2
	15	2AR02060	LOWER LEFT REINFORCEMENT	1	1	1
	16	3AT02080	UPPER LEFT FRAME	1	1	1
	17	3AT02060	UPPER REAR FRAME	1	1	1
	18	3AT02070	UPPER RIGHT FRAME	1	1	1
	19	3AT02033	REAR FRAME	1	1	1
	20	3AT02180	LOWER REAR FRAME	1	1	1
	21	2AR02050	LOWER RIGHT REINFORCEMENT	1	1	1
	22	3AT02010	RIGHT FRONT FRAME	1	1	1
	23	3AT02042	BASE,DESK	1	1	1
	24	3AT02051	UPPER FRONT FRAME	1	1	1
	25	3AT02023	LEFT FRONT FRAME	1	1	1
	26	3AT02261	MOUNT C LEVEL BOLT	1	1	1
	27	3AT02271	MOUNT D LEVEL BOLT	1	1	1

- Parts with "•" are component parts or sub-assemblies of the assembly appearing immediately above them.
- Parts with "●" indicates the Service parts.

FIG. 3 CASSETTE

3CC

SP	Ref. No.	Part. No.	Description	Quantity		
				120V	230V	240V
	1	2AR07010	CASSETTE	2	2	2
	2	J0463080	PLUG,QR/P15-8S-C(HIROSE)	2	2	2
●	3	2AR05150	LABEL,CASSETTE OPERATION	2	2	2
	4	2AR05200	LABEL,PAPER UPPER LIMIT	2	2	2
	5	2AR07020	BASE,CASSETTE	2	2	2
	6	2AR07030	WORK PLATE,CASSETTE BASE	2	2	2
	7	2AR07040	SHAFT,WORK PLATE	2	2	2
	8	2AR07050	RAIL A,CURSOR	2	2	2
	9	2AR07060	CURSOR A,CASSETTE	2	2	2
	10	2AR07070	CURSOR B,CASSETTE	2	2	2
	11	2AR07080	CURSOR C,CASSETTE	2	2	2
	12	2AR07090	RAIL C,CURSOR	2	2	2
	13	2AR07100	FRONT GUIDE C,CURSOR	2	2	2
	14	2AR07110	REAR GUIDE C,CURSOR	2	2	2
	15	2AR07120	LID A,CURSOR	2	2	2
●	16	2BL04140	COVER CASSETTE	2	2	2
●	17	2AR07150	GROUND PLATE,CASSETTE	2	2	2
	18	2AR07160	MOUNT,CASSETTE STOPPER	2	2	2
	19	2AR07180	RETAINER M4	6	6	6
	20	2AR07190	SHAFT,CASSETTE PULLEY	4	4	4
	21	2AR07340	LEVER A,CURSOR	2	2	2
	22	2AR07610	STOPPER,TRAILING EDGE DETECTION	2	2	2
	23	2AR07620	PROTECTING PLATE,CASSETTE WIRE	2	2	2
	24	2AR07630	LID,TRAILING EDGE DETECTION PLATE	2	2	2
	25	2AR27220	WIRE,CASSETTE UNIT	2	2	2
●	26	33907100	RACK,CASSETTE	4	4	4
●	27	33907170	DETECTION PLATE,PAPER SIZE	2	2	2
	28	33907210	CUSHION,CASSETTE WORK PLATE	4	4	4
●	29	33928111	SIZE DETECTION PCB	2	2	2
●	30	34907150	PULLEY,CASSETTE	4	4	4
●	31	60907170	CUSHION,CASSETTE R	4	4	4
●	32	65914120	GEAR 18,IDLE DEVELOPING	2	2	2
●	33	66007120	SPRING,CURSOR C	2	2	2
●	34	66106080	SPRING,PAD	2	2	2
●	35	66107100	PAD,CASSETTE	2	2	2
	36	77906210	CASSETTE STOPPER	2	2	2
	37	33907110	TERMINAL,PAPER SIZE PCB	2	2	2
●	38	2BL04160	HANDLE CASSETTE	2	2	2
●	39	2BL06470	PLATE SIZE C		2	2
●	39	2BL06910	PLATE SIZE IN	2		

SP	Ref. No.	Part. No.	Description	Quantity		
				120V	230V	240V
	40	3CF04050	PLATE NUMBER 3	1	1	1
	41	3CF04060	PLATE NUMBER4	1	1	1
	42	2BL06980	MOUNT CUSHION	4	4	4

- Parts with "●" are component parts or sub-assemblies of the assembly appearing immediately above them.
- Parts with "●" indicates the Service parts.

FIG. 4 PAPER FEED-IN SECTION

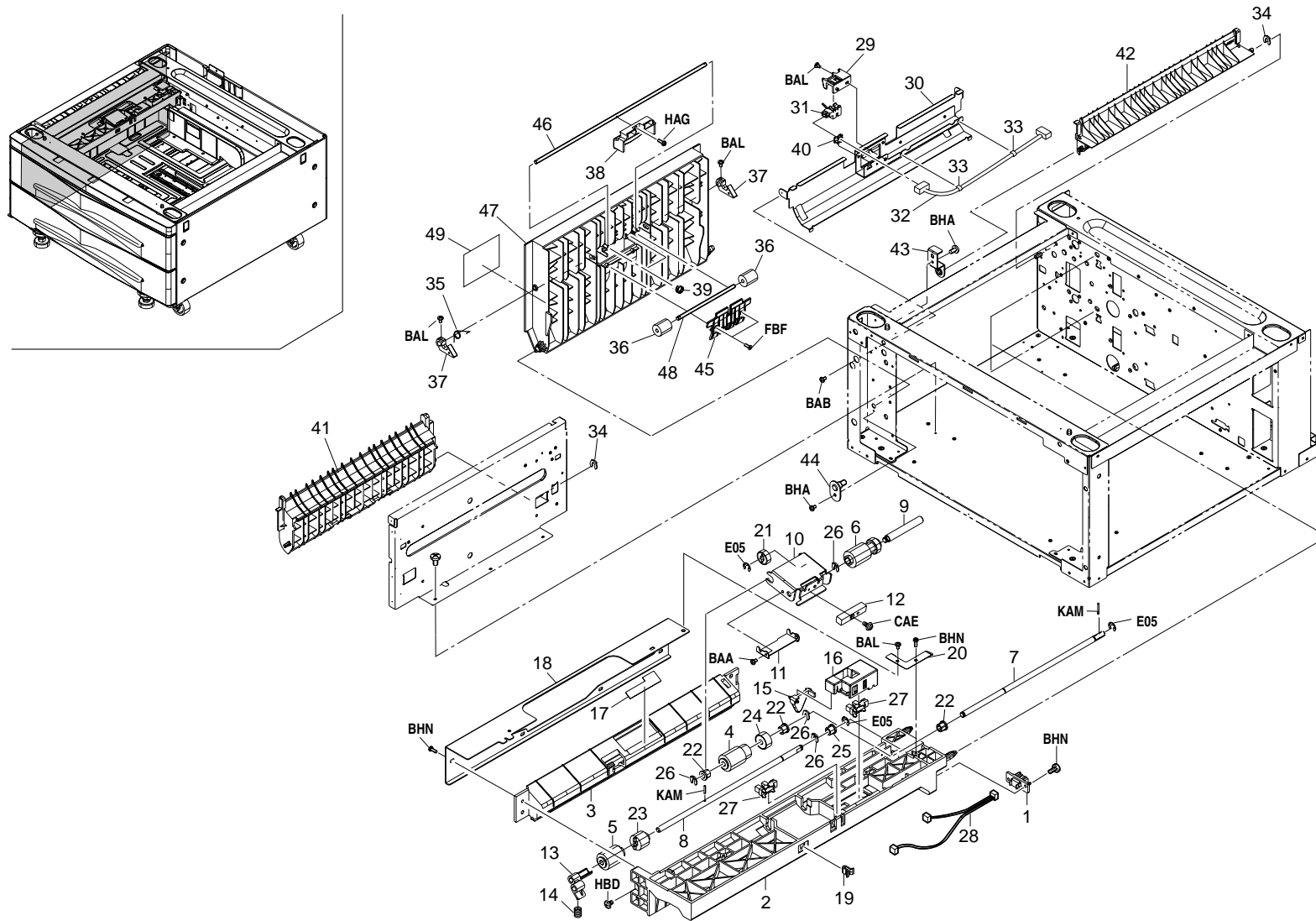

FIG. 4 PAPER FEED-IN SECTION

3CC

SP	Ref. No.	Part. No.	Description	Quantity		
				120V	230V	240V
	1	J0463080	PLUG,QR/P15-8S-C(HIROSE)	2	2	2
	2	2AR07200	UPPER HOUSING,PAPER FEED	2	2	2
	3	2AR07210	LOWER HOUSING,PAPER FEED	2	2	2
●	4	2AR07220	PULLEY,PAPER FEED	2	2	2
●	5	2AR07230	PULLEY,SEPARATION	2	2	2
●	6	2AR07240	PULLEY,LEADING FEED	2	2	2
	7	2AR07250	SHAFT,PAPER FEED	2	2	2
	8	2AR07260	SHAFT,SEPARATION	2	2	2
	9	2AR07270	SHAFT,LEADING FEED	2	2	2
	10	2AR07280	SUPPORT PLATE,LEADING FEED PULLEY	2	2	2
	11	2AR07290	REINFORCEMENT,LEADING FEED SUPPORT PLATE	2	2	2
	12	2AR07300	WEIGHT,LEADING FEED PULLEY	2	2	2
	13	2AR07310	LEVER,SEPARATION PULLEY RELEASE	2	2	2
●	14	2AR07350	SPRING,SEPARATION PULLEY	2	2	2
●	15	2AR07640	ACTUATOR,PAPER EMPTY	2	2	2
	16	2AR07650	HOLDER,ACTUATOR	2	2	2
	17	2AR07660	GUIDE FILM,SEPARATION PULLEY	2	2	2
	18	2AR07670	REINFORCEMENT,PRIMARY PAPER FEED	2	2	2
	19	2AR07690	STOPPER,SUPPORT PLATE	2	2	2
●	20	2AR07790	GROUND PLATE,PRIMARY PAPER FEED	2	2	2
●	21	45729206	GEAR,TONER FEED ROLLER	2	2	2
●	22	29806810	BUSHING,6 REGISTRATION	6	6	6
●	23	33906070	TORQUE LIMITER,PAPER FEED	2	2	2
●	24	33906160	GEAR 16,PAPER FEED	2	2	2
●	25	34806040	LOWER BUSHING,PAPER FEED	2	2	2
	26	34806140	STOPPER 4	8	8	8
●	27	35327400	SWITCH,FEED	4	4	4
	28	2AR27430	WIRE,PRIMARY PAPER FEED UNIT	2	2	2
	29	2AR06070	MOUNT,REGISTRATION SW	1	1	1
	30	3AT02240	GUIDE,VERTICAL CONVEYING	1	1	1
●	31	33906140	SWITCH,VERTICAL CONVEYING	1	1	1
	32	3AT27040	JUNCTION WIRING,FEED SWITCH	1	1	1
	33	M2607010	BINDING BAND,PLT1M	2	2	2
	34	34806150	STOPPER 5	2	2	2
●	35	2AR07880	SPRING,FEED RELEASE	1	1	1
●	36	33906660	RIGHT PULLEY,FEED	2	2	2
	37	33906670	RIGHT HOOK,FEED RELEASE	2	2	2
●	38	68204180	RIGHT HANDLE,FEED RELEASE(K M)	1	1	1
●	39	66106610	SPRING,FEED	2	2	2
	40	M2104260	EDGING,EDS-0607U(KITAGAWA)	1	1	1

SP	Ref. No.	Part. No.	Description	Quantity		
				120V	230V	240V
	41	2AR07470	LOWER LEFT GUIDE,VERTICAL CONVEYING	1	1	1
	42	3AT07010	UPPER LEFT GUIDE VERTICAL CONVEYING	1	1	1
	43	3AT07020	FRONT FULCRUM PLATE CONVEYING GUIDE	1	1	1
	44	3CF02010	FULCRUM PIN,COVER VERTICAL CONVEYING	1	1	1
	45	3CF04110	GUIDE,VERTICAL CONVEYING	1	1	1
	46	2AR07600	SHAFT,VERTICAL CONVEYING	1	1	1
●	47	3CF04090	COVER,VERTICAL CONVEYING	1	1	1
	48	3AT07050	SHAFT,VERTICAL CONVEYING	1	1	1
●	49	3AT05070	LABEL,STOPPER	1	1	1

- Parts with "●" are component parts or sub-assemblies of the assembly appearing immediately above them.
- Parts with "●" indicates the Service parts.

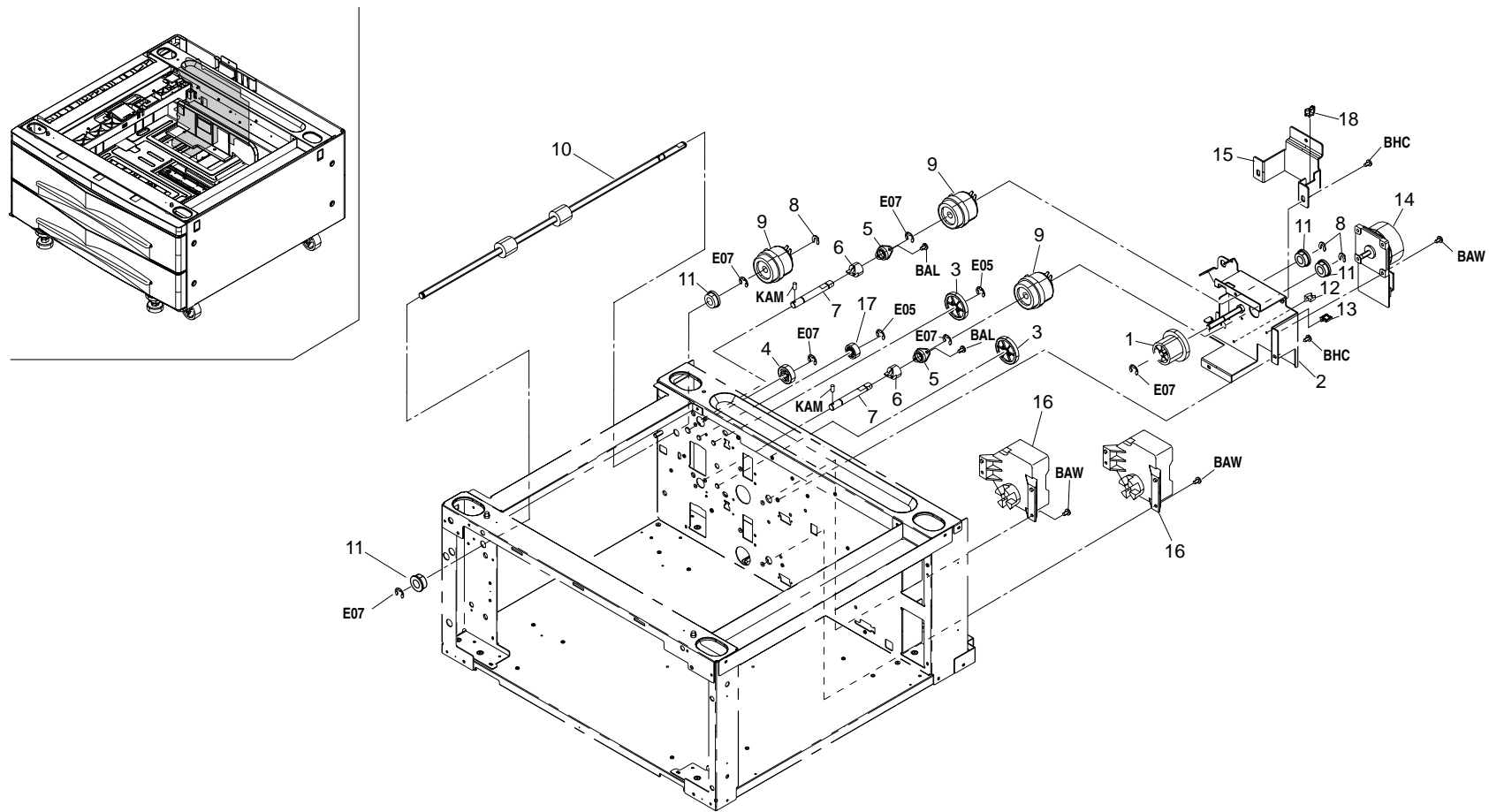

FIG. 5 DRIVING SECTION

3CC

SP	Ref. No.	Part. No.	Description	Quantity		
				120V	230V	240V
●	1	3AT02200	GEAR 67/34 IDLE	1	1	1
	2	3AT02210	MOUNT DESK MOTOR	1	1	1
●	3	36715380	GEAR 41,HOPPER AGITATION	2	2	2
●	4	45727303	GEAR 26,CLUTCH	1	1	1
●	5	2AR07700	BUSHING,PRIMARY PAPER FEED	2	2	2
●	6	2AR07320	COUPLING,PAPER FEED	2	2	2
	7	3AT02220	SHAFT PRIMARY PAPER FEED CLUTCH	2	2	2
	8	34806150	STOPPER 5	3	3	3
●	9	2AC06230	CLUTCH,RESISTRATION	3	3	3
●	10	2AR07420	ROLLER,VERTICAL CONVEYING	1	1	1
●	11	67322230	BUSHING 8	4	4	4
	12	M2105730	MINIATURE CLAMP,UAMS-07-0	1	1	1
	13	M7009020	WIRE SADDLE,LWS-1N-V0F(TAKEUCHI)	1	1	1
●	14	3AT93010	PARTS,MOTOR DESK,SP	1	1	1
	15	3AT02150	MOUNT,MACHINE	1	1	1
●	16	2BL27580	LIFT MOTOR	2	2	2
●	17	2AC18280	GEAR 20,SPIRAL	1	1	1
	18	M2104210	EDGING,EDS-2	1	1	1

- Parts with "●" are component parts or sub-assemblies of the assembly appearing immediately above them.
- Parts with "●" indicates the Service parts.

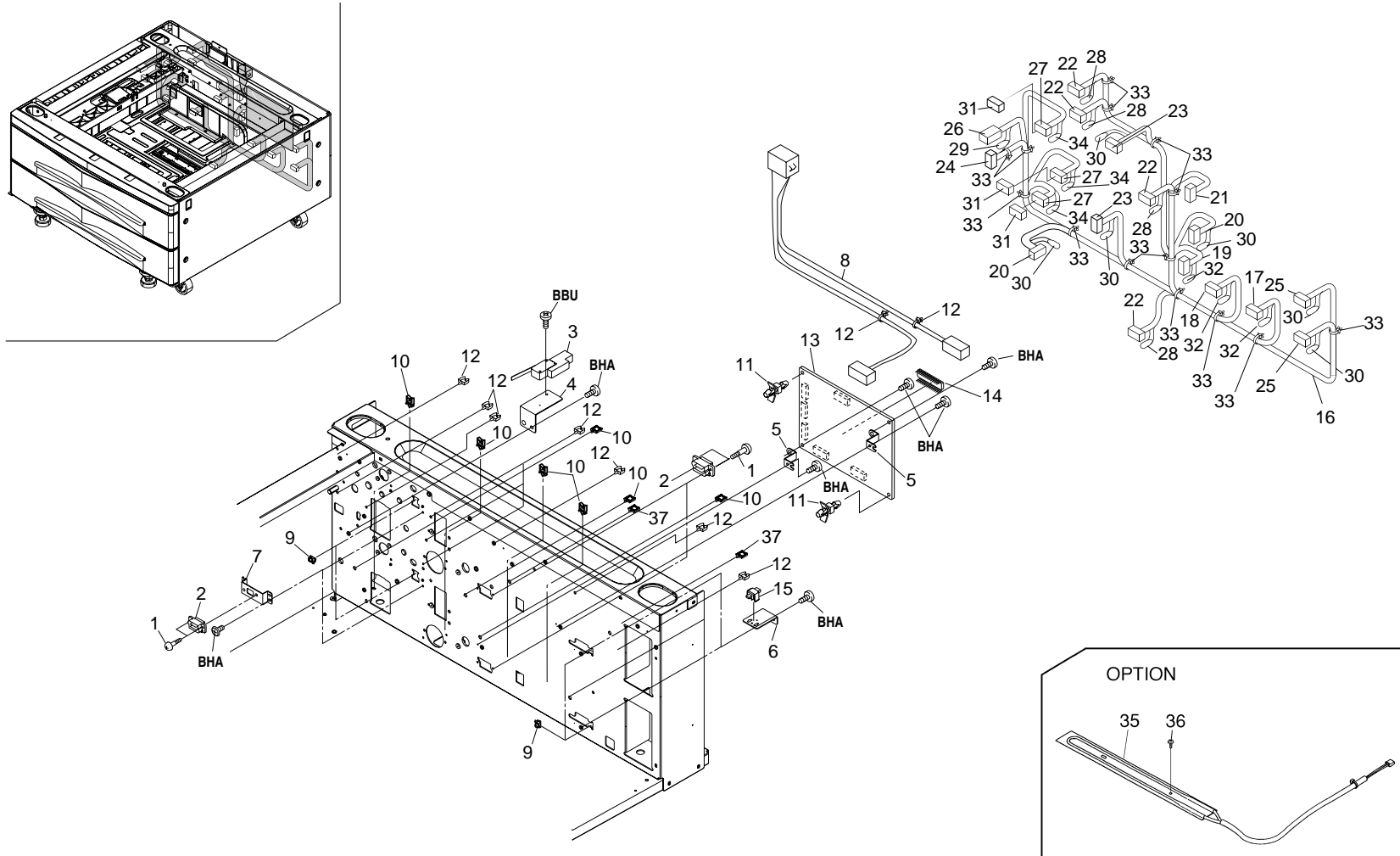

FIG. 6 ELECTRICAL COMPONENTS

3CC

SP	Ref. No.	Part. No.	Description	Quantity			
				120V	230V	240V	
●	1	33927450	RETAINING PIN,DRAWER	8	8	8	
	2	J0464080	RECEPTACLE,QR/P15-8S-C(02)(HIROSE)	4	4	4	
	3	61727540	INTERLOCK SWITCH B	1	1	1	
	4	3AT02140	MOUNT,RELEASE SWITCH	1	1	1	
	5	3AT02230	MOUNT,PCB	2	2	2	
	6	2AR07170	MOUNT,CASSETTE SWITCH	2	2	2	
	7	2AR07710	MOUNT,PAPER FEED DRAWER	2	2	2	
	8	3AT27020	WIRE,INPUT	1	1	1	
	9	M2104260	EDGING,EDS-0607U(KITAGAWA)	4	4	4	
	10	M2109010	WIRE SADDLE,WS-2NS	7	7	7	
●	11	M2108360	SPACER,KGLS-12S	2	2	2	
	12	M2105730	MINIATURE CLAMP,UAMS-07-0	11	11	11	
	13	3CC28010	DESK PCB	1	1	1	
	14	3CC27010	IC,MAIN PCB(C P U)	1	1	1	
	15	66127010	SWITCH,COVER OPEN	2	2	2	
	16	3CF27010	WIRE,MAIN	1	1	1	
	17	●J5080160	RECEPTACLE,PHDR-16VS(JST)	1	1	1	
	18	●J5080180	RECEPTACLE,PHDR-18VS(JST)	1	1	1	
	19	●J5080120	RECEPTACLE,PHDR-12VS(JST)	1	1	1	
	20	●J0150070	RECEPTACLE,175778-7(AMP)	2	2	2	
	21	●J5000030	PLUG PH 3P,PHR-3	1	1	1	
	22	●J0441080	RECEPTACLE,DF11-8DS-2C(HIROSE)	4	4	4	
	23	●J0150050	RECEPTACLE,175778-5(AMP)	2	2	2	
	24	●J5060030	POSITIVE,RECEPTACLE,3V-187(JST)	1	1	1	
	25	●J0150020	RECEPTACLE,175778-2(AMP)	2	2	2	
	26	●J0450030	PLUG,DF3-3S-2C(HIROSE)	1	1	1	
	27	●J5003030	RECEPTACLE,PHNR-03C-H(JST)	3	3	3	
	28	●J0441900	CONTACTOR,DF11-2428SC	24	24	24	
	29	●J0450900	SOCKET,DF3-2428SC(HIROSE)	3	3	3	
	30	●J0150900	CONTACTOR,175161-1(AMP)	28	28	28	
	31	●J5016030	CASE,BU03P-TR-PC-H(JST)	3	3	3	
	32	●J5080900	SOCKET,BPHD-002T-P0.5(JST)	43	43	43	
	33	●M0207000	BINDING BAND,KB-100-1	14	14	14	
	34	●J5000810	CONTACT,SPH-002T-P0.5L	6	6	6	
	●	35	33960020	HEATER,CASSETTE (240)		1	1
		35	34860030	HEATER,CASSETTE(120)	1		
		36	B1304060	BINDING SCREW BVM4X6 (BLACK)	2	2	2
37		M7009020	WIRE SADDLE,LWS-1N-V0F(TAKEUCHI)	2	2	2	

- Parts with "●" are component parts or sub-assemblies of the assembly appearing immediately above them.
- Parts with "●" indicates the Service parts.

INDEX

3CC

SP	Part. No.	Description	Quantity			Fig. No.
			120V	230V	240V	
●	2AC06230	CLUTCH,RESISTRATION	3	3	3	5
●	2AC18280	GEAR 20,SPIRAL	1	1	1	5
	2AR02050	LOWER RIGHT REINFORCEMENT	1	1	1	2
	2AR02060	LOWER LEFT REINFORCEMENT	1	1	1	2
●	2AR05150	LABEL,CASSETTE OPERATION	2	2	2	3
	2AR05200	LABEL,PAPER UPPER LIMIT	2	2	2	3
	2AR06070	MOUNT,REGISTRATION SW	1	1	1	4
	2AR07010	CASSETTE	2	2	2	3
	2AR07020	BASE,CASSETTE	2	2	2	3
	2AR07030	WORK PLATE,CASSETTE BASE	2	2	2	3
	2AR07040	SHAFT,WORK PLATE	2	2	2	3
	2AR07050	RAIL A,CURSOR	2	2	2	3
	2AR07060	CURSOR A,CASSETTE	2	2	2	3
	2AR07070	CURSOR B,CASSETTE	2	2	2	3
	2AR07080	CURSOR C,CASSETTE	2	2	2	3
	2AR07090	RAIL C,CURSOR	2	2	2	3
	2AR07100	FRONT GUIDE C,CURSOR	2	2	2	3
	2AR07110	REAR GUIDE C,CURSOR	2	2	2	3
	2AR07120	LID A,CURSOR	2	2	2	3
	2AR07140	LEFT RAIL,CASSETTE	2	2	2	2
●	2AR07150	GROUND PLATE,CASSETTE	2	2	2	3
	2AR07160	MOUNT,CASSETTE STOPPER	2	2	2	3
	2AR07170	MOUNT,CASSETTE SWITCH	2	2	2	6
	2AR07180	RETAINER M4	6	6	6	3
	2AR07190	SHAFT,CASSETTE PULLEY	4	4	4	3
	2AR07200	UPPER HOUSING,PAPER FEED	2	2	2	4
	2AR07210	LOWER HOUSING,PAPER FEED	2	2	2	4
●	2AR07220	PULLEY,PAPER FEED	2	2	2	4
●	2AR07230	PULLEY,SEPARATION	2	2	2	4
●	2AR07240	PULLEY,LEADING FEED	2	2	2	4
	2AR07250	SHAFT,PAPER FEED	2	2	2	4
	2AR07260	SHAFT,SEPARATION	2	2	2	4
	2AR07270	SHAFT,LEADING FEED	2	2	2	4
	2AR07280	SUPPORT PLATE,LEADING FEED PULLEY	2	2	2	4
	2AR07290	REINFORCEMENT,LEADING FEED SUPPORT	2	2	2	4
	2AR07300	WEIGHT,LEADING FEED PULLEY	2	2	2	4
	2AR07310	LEVER,SEPARATION PULLEY RELEASE	2	2	2	4
●	2AR07320	COUPLING,PAPER FEED	2	2	2	5
	2AR07340	LEVER A,CURSOR	2	2	2	3
●	2AR07350	SPRING,SEPARATION PULLEY	2	2	2	4

SP	Part. No.	Description	Quantity			Fig. No.
			120V	230V	240V	
●	2AR07420	ROLLER,VERTICAL CONVEYING	1	1	1	5
	2AR07470	LOWER LEFT GUIDE,VERTICAL CONVEYIN	1	1	1	4
	2AR07600	SHAFT,VERTICAL CONVEYING	1	1	1	4
	2AR07610	STOPPER,TRAILING EDGE DETECTION	2	2	2	3
	2AR07620	PROTECTING PLATE,CASSETTE WIRE	2	2	2	3
	2AR07630	LID,TRAILING EDGE DETECTION PLATE	2	2	2	3
●	2AR07640	ACTUATOR,PAPER EMPTY	2	2	2	4
	2AR07650	HOLDER,ACTUATOR	2	2	2	4
	2AR07660	GUIDE FILM,SEPARATION PULLEY	2	2	2	4
	2AR07670	REINFORCEMENT,PRIMARY PAPER FEED	2	2	2	4
	2AR07690	STOPPER,SUPPORT PLATE	2	2	2	4
●	2AR07700	BUSHING,PRIMARY PAPER FEED	2	2	2	5
	2AR07710	MOUNT,PAPER FEED DRAWER	2	2	2	6
	2AR07720	COVER,CASSETTE RAIL	2	2	2	1
●	2AR07790	GROUND PLATE,PRIMARY PAPER FEED	2	2	2	4
●	2AR07800	PULLEY,CASSETTE RAIL	8	8	8	2
	2AR07810	FRONT PIN,CASSETTE RAIL	4	4	4	2
	2AR07820	REAR PIN,CASSETTE RAIL	4	4	4	2
●	2AR07880	SPRING,FEED RELEASE	1	1	1	4
	2AR27220	WIRE,CASSETTE UNIT	2	2	2	3
	2AR27430	WIRE,PRIMARY PAPER FEED UNIT	2	2	2	4
●	2BL04140	COVER CASSETTE	2	2	2	3
	2BL04160	HANDLE CASSETTE	2	2	2	3
●	2BL06470	PLATE SIZE C		2	2	3
●	2BL06910	PLATE SIZE IN	2			3
	2BL06980	MOUNT CUSHION	4	4	4	3
●	2BL27580	LIFT MOTOR	2	2	2	5
●	29806810	BUSHING,6 REGISTRATION	6	6	6	4
	3AT02010	RIGHT FRONT FRAME	1	1	1	2
	3AT02023	LEFT FRONT FRAME	1	1	1	2
	3AT02033	REAR FRAME	1	1	1	2
	3AT02042	BASE,DESK	1	1	1	2
	3AT02051	UPPER FRONT FRAME	1	1	1	2
	3AT02060	UPPER REAR FRAME	1	1	1	2
	3AT02070	UPPER RIGHT FRAME	1	1	1	2
	3AT02080	UPPER LEFT FRAME	1	1	1	2
	3AT02092	MOUNT A LEVEL BOLT	1	1	1	2
	3AT02101	MOUNT B LEVEL BOLT	1	1	1	2
	3AT02110	MOUNT SORTER	2	2	2	1
	3AT02120	REAR MOUNT,COVER	3	3	3	1

• Parts with "●" indicates the Service parts.

SP	Part. No.	Description	Quantity			Fig. No.
			120V	230V	240V	
	3AT02130	FRONT PIN HOOK	1	1	1	2
	3AT02140	MOUNT,RELEASE SWITCH	1	1	1	6
	3AT02150	MOUNT,MACHINE	1	1	1	5
	3AT02180	LOWER REAR FRAME	1	1	1	2
●	3AT02200	GEAR 67/34 IDLE	1	1	1	5
	3AT02210	MOUNT DESK MOTOR	1	1	1	5
	3AT02220	SHAFT PRIMARY PAPER FEED CLUTCH	2	2	2	5
	3AT02230	MOUNT,PCB	2	2	2	6
	3AT02240	GUIDE,VERTICAL CONVEYING	1	1	1	4
	3AT02250	FULCRUM PLATE	2	2	2	2
	3AT02261	MOUNT C LEVEL BOLT	1	1	1	2
	3AT02271	MOUNT D LEVEL BOLT	1	1	1	2
●	3AT05070	LABEL,STOPPER	4	4	4	1, 4
	3AT07010	UPPER LEFT GUIDE VERTICAL CONVEYIN	1	1	1	4
	3AT07020	FRONT FULCRUM PLATE CONVEYING GUI	1	1	1	4
	3AT07050	SHAFT,VERTICAL CONVEYING	1	1	1	4
	3AT27020	WIRE,INPUT	1	1	1	6
	3AT27040	JUNCTION WIRING,FEED SWITCH	1	1	1	4
●	3AT93010	PARTS,MOTOR DESK,SP	1	1	1	5
●	3CC27010	IC,MAIN PCB(C P U)	1	1	1	6
●	CC28010	DESK PCB	1	1	1	6
	3CF02010	FULCRUM PIN,COVER VERTICAL CONVEYI	1	1	1	4
●	3CF04010	UPPER FRONT COVER	1	1	1	1
●	3CF04020	LOWER FRONT COVER	1	1	1	1
	3CF04030	LEFT FRONT COVER	1	1	1	1
	3CF04040	LEFT FRONT MOUNT,COVER	2	2	2	1
	3CF04050	PLATE NUMBER 3	1	1	1	3
	3CF04060	PLATE NUMBER4	1	1	1	3
●	3CF04070	LEFT COVER	1	1	1	1
●	3CF04080	LID,COVER	2	2	2	1
●	3CF04090	COVER,VERTICAL CONVEYING	1	1	1	4
●	3CF04100	RIGHT COVER	1	1	1	1
	3CF04110	GUIDE,VERTICAL CONVEYING	1	1	1	4
	3CF27010	WIRE,MAIN	1	1	1	6
●	33906070	TORQUE LIMITER,PAPER FEED	2	2	2	4
●	33906140	SWITCH,VERTICAL CONVEYING	1	1	1	4
●	33906160	GEAR 16,PAPER FEED	2	2	2	4
●	33906660	RIGHT PULLEY,FEED	2	2	2	4
●	33906670	RIGHT HOOK,FEED RELEASE	2	2	2	4
●	33907100	RACK,CASSETTE	4	4	4	3

SP	Part. No.	Description	Quantity			Fig. No.
			120V	230V	240V	
	33907110	TERMINAL,PAPER SIZE PCB	2	2	2	3
●	33907170	DETECTION PLATE,PAPER SIZE	2	2	2	3
	33907210	CUSHION,CASSETTE WORK PLATE	4	4	4	3
	33927450	RETAINING PIN,DRAWER	8	8	8	6
●	33928111	SIZE DETECTION PCB	2	2	2	3
●	33960020	HEATER,CASSETTE (240)		1	1	6
●	34806040	LOWER BUSHING,PAPER FEED	2	2	2	4
	34806140	STOPPER 4	8	8	8	4
	34806150	STOPPER 5	5	5	5	4, 5
●	34860030	HEATER,CASSETTE(120)	1			6
●	34907150	PULLEY,CASSETTE	4	4	4	3
●	35327400	SWITCH,FEED	4	4	4	4
	36502600	CASTER,MACHINE	4	4	4	2
●	36715380	GEAR 41,HOPPER AGITATION	2	2	2	5
●	45727303	GEAR 26,CLUTCH	1	1	1	5
●	45729206	GEAR,TONER FEED ROLLER	2	2	2	4
	60907170	CUSHION,CASSETTE R	4	4	4	3
●	61727540	INTERLOCK SWITCH B	1	1	1	6
	64007010	PIN,CLEANER	2	2	2	2
●	65914120	GEAR 18,IDLE DEVELOPING	2	2	2	3
●	66007120	SPRING,CURSOR C	2	2	2	3
●	66106080	SPRING,PAD	2	2	2	3
●	66106610	SPRING,FEED	2	2	2	4
●	66107100	PAD,CASSETTE	2	2	2	3
●	66127010	SWITCH,COVER OPEN	2	2	2	6
	66502120	BOLT,LEVEL	4	4	4	2
●	67322230	BUSHING 8	4	4	4	5
●	68204120	REAR COVER(K M)	1	1	1	1
	68204160	COVER,CONNECTOR(K M)	1	1	1	1
●	68204180	RIGHT HANDLE,FEED RELEASE(K M)	1	1	1	4
	77906210	CASSETTE STOPPER	2	2	2	3
	77906291	HOLDER,CASSETTE STOPPER	2	2	2	2
	B1304060	BINDING SCREW BVM4X6 (BLACK)	2	2	2	6
	J0150020	RECEPTACLE,175778-2(AMP)	2	2	2	6
	J0150050	RECEPTACLE,175778-5(AMP)	2	2	2	6
	J0150070	RECEPTACLE,175778-7(AMP)	2	2	2	6
	J0150900	CONTACTOR,175161-1(AMP)	28	28	28	6
	J0441080	RECEPTACLE,DF11-8DS-2C(HIROSE)	4	4	4	6
	J0441900	CONTACTOR,DF11-2428SC	24	24	24	6
	J0450030	PLUG,DF3-3S-2C(HIROSE)	1	1	1	6

• Parts with "●" indicates the Service parts.

SP	Part. No.	Description	Quantity			Fig. No.
			120V	230V	240V	
	J0450900	SOCKET,DF3-2428SC(HIROSE)	3	3	3	6
	J0463080	PLUG,QR/P15-8S-C(HIROSE)	4	4	4	3, 4
	J0464080	RECEPTACLE,QR/P15-8S-C(02)(HIROSE)	4	4	4	6
	J5000030	PLUG PH 3P,PHR-3	1	1	1	6
	J5000810	CONTACT,SPH-002T-P0.5L	6	6	6	6
	J5003030	RECEPTACLE,PHNR-03C-H(JST)	3	3	3	6
	J5016030	CASE,BU03P-TR-PC-H(JST)	3	3	3	6
	J5060030	POSITIVE,RECEPTACLE,3V-187(JST)	1	1	1	6
	J5080120	RECEPTACLE,PHDR-12VS(JST)	1	1	1	6
	J5080160	RECEPTACLE,PHDR-16VS(JST)	1	1	1	6
	J5080180	RECEPTACLE,PHDR-18VS(JST)	1	1	1	6
	J5080900	SOCKET,BPHD-002T-P0.5(JST)	43	43	43	6
	M0207000	BINDING BAND,KB-100-1	14	14	14	6
	M2104210	EDGING,EDS-2	1	1	1	5
	M2104260	EDGING,EDS-0607U(KITAGAWA)	5	5	5	4, 6
	M2104350	EDGING,EDS-0607M(KITAGAWA)	1	1	1	2
	M2105730	MINIATURE CLAMP,UAMS-07-0	12	12	12	5, 6
	M2108360	SPACER,KGLS-12S	2	2	2	6
	M2109010	WIRE SADDLE,WS-2NS	7	7	7	6
	M2109330	WIRE SADDLE,YMC-10-0(KITAGAWA)	1	1	1	2
	M2607010	BINDING BAND,PLT1M	2	2	2	4
	M7009020	WIRE SADDLE,LWS-1N-V0F(TAKEUCHI)	3	3	3	5, 6

• Parts with "●" indicates the Service parts.