

# Section 3

## Parts Lists

- PL 1 Covers..... 3-2*
- PL 2 Front Cover..... 3-4*
- PL 3 Paper Trays..... 3-6*
- PL 4 Feeder ..... 3-8*
- PL 5 Paper Transport ..... 3-10*
- PL 6 Frame Assembly (1 of 2) ..... 3-12*
- PL 7 Frame Assembly (2 of 2) ..... 3-14*
- PL 8 Fuser ..... 3-16*
- PL 9 Main Drive Motor ..... 3-18*
- PL 10 Electronics..... 3-20*

# PL 1 Covers

<b>Item</b>	<b>Part Number</b>	<b>Description</b>
1)	-----	Top Cover}
2)	802E00400	Rear Cover
3)	-----	Right Side Cover
4)	-----	Bottom Cover
5)	-----	Face Up Cover
6)	802E00380	Front Cover
7)	-----	Left Side Cover
8)	113R00296	Print Cartridge
A)	600K72020	Hardware Kit

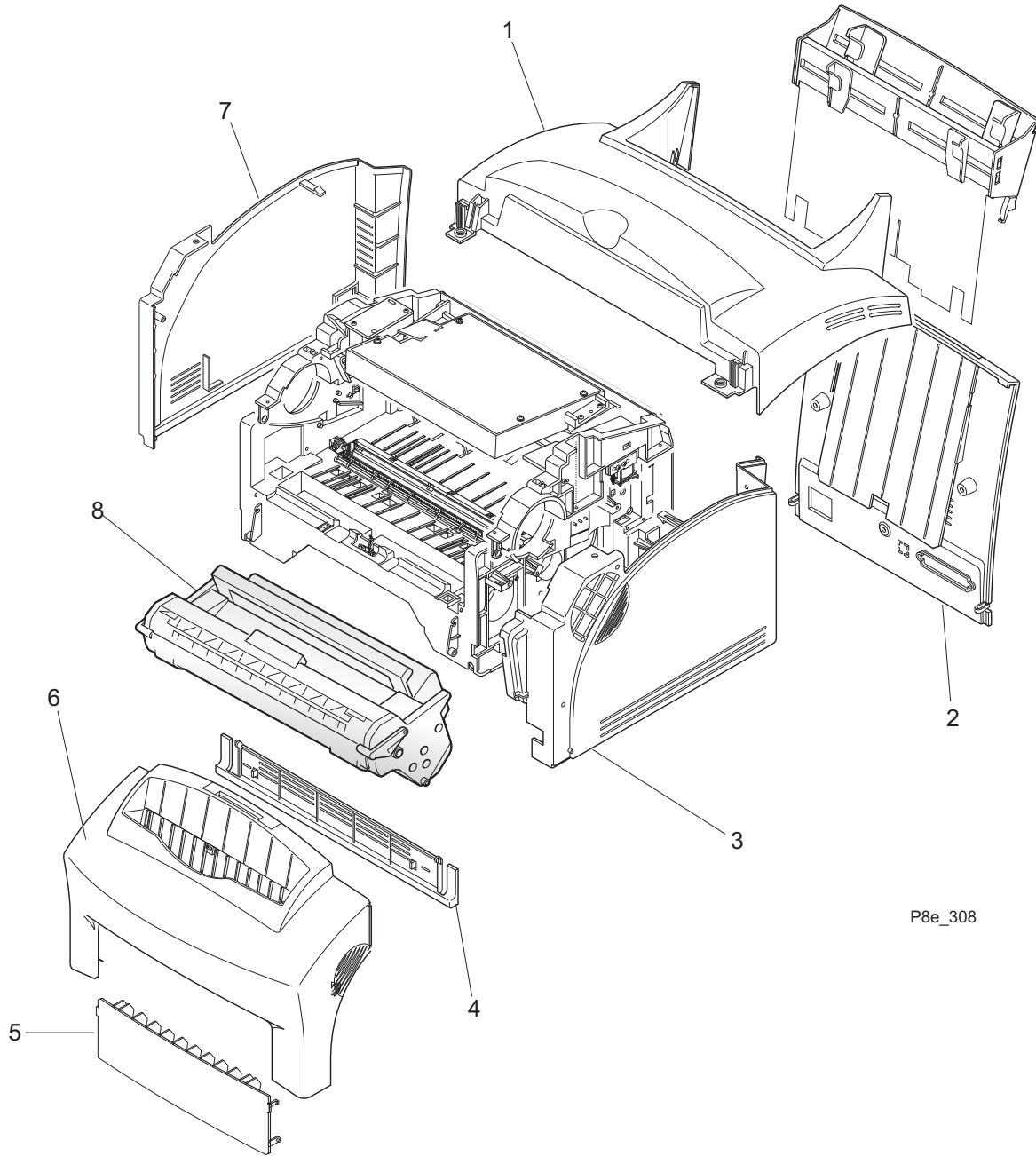

P8e\_308

## PL 2 Front Cover

Item	Part Number	Description
1)	-----	Front Cover {Includes Items 2 through 7}
2)	-----	Stacker Extender
3)	-----	Stacker
4)	-----	Duct
5)	802E00380	Front Cover
6)	-----	Stacker Guide
7)	-----	Stopper
8)	3E50440	Key
9)	107E16960	LED
10)	101E19680	Control Panel
11)	-----	Control Panel Cover
12)	802E00390	Face Up Exit Cover
A)	600K72020	Hardware Kit

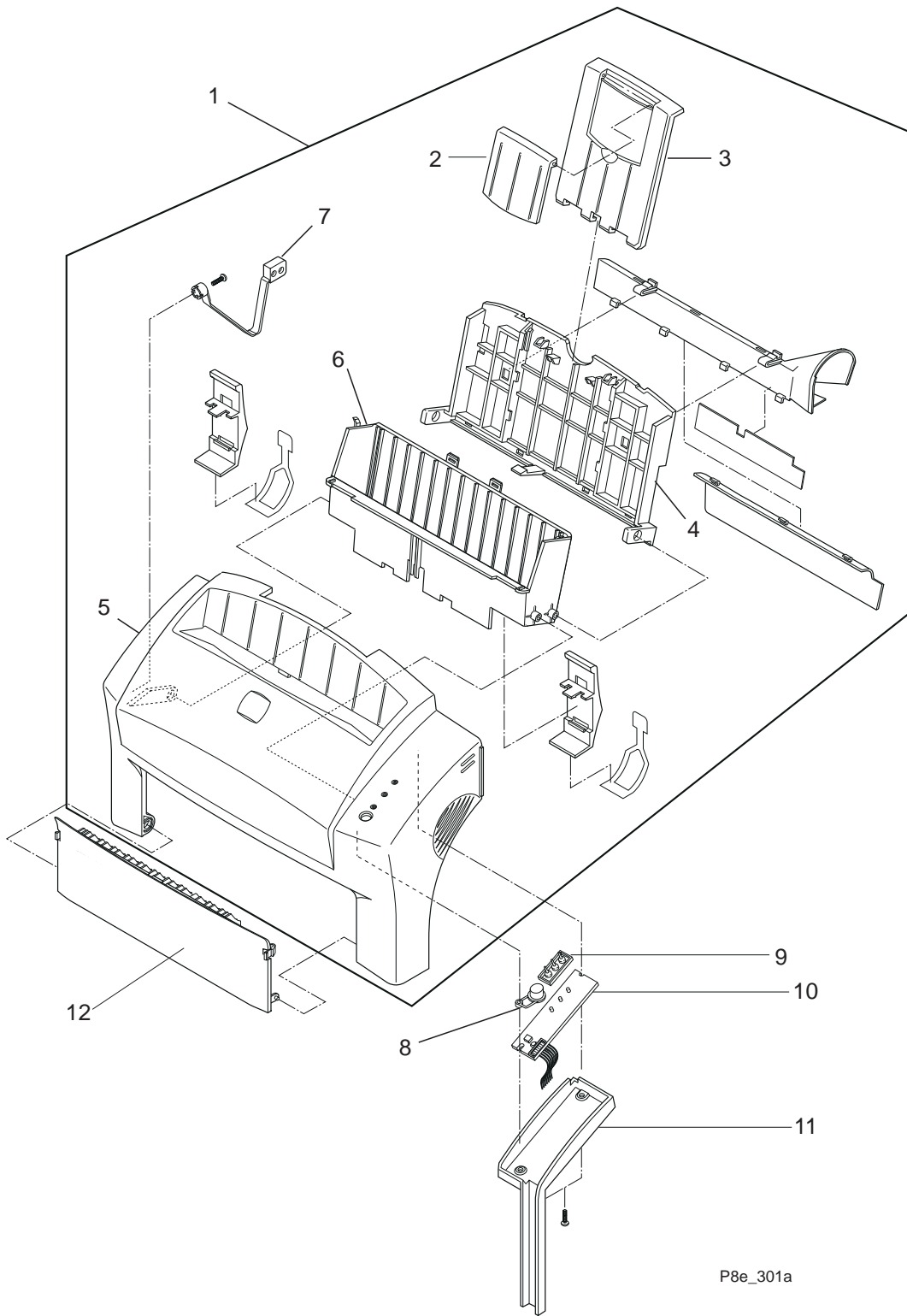

## PL 3 Paper Trays

Item	Part Number	Description
1)	-----	Media (Paper) Tray {Includes Items 2 through 12}
2)	-----	Gear Adjust Rack, Left
3)	-----	Gear Adjust Rack, Right
4)	-----	Pinion Gear
5)	-----	Auto Tray Adjust, Right
6)	-----	Manual Tray Adjust, Right
7)	-----	Film Guide Sheet
8)	-----	Manual Tray Adjust, Left
9)	-----	Manual Paper Tray
10)	-----	Auto Tray Adjust, Left
11)	-----	Paper Guide Plate
12)	-----	Rear Cover Assembly {Includes Items 13 & 14}
13)	50E15050	Tray Extender
14)	802E00400	Rear Cover
A)	600K72020	Hardware Kit

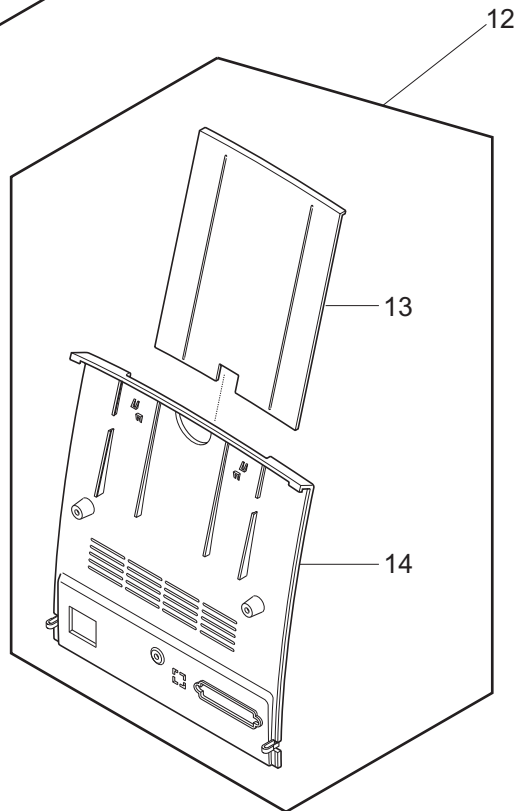
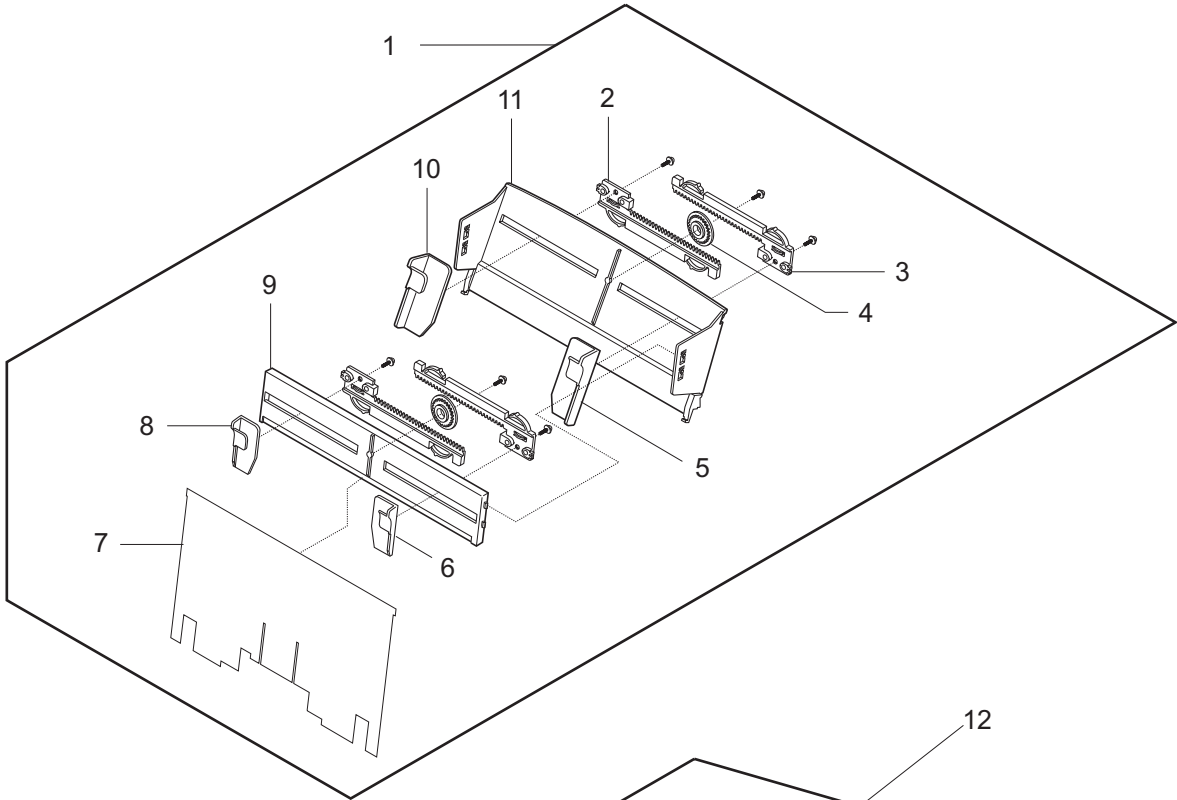

P8e\_302

## PL 4 Feeder

Item	Part Number	Description
1)	19K04760	Paper Separator Unit {Includes Items 2 & 3}
2)	-----	Separator Pad
3)	-----	Separator Holder
4)	809E18310	Knock Up Spring
5)	19K04770	Knock Up Spring Holder Assembly {Includes Items 6 & 7}
6)	-----	Knock Up Spring Holder
7)	-----	Knock Up Ground
8)	-----	Separator Spring
9)	15K39950	Media Unit Knock Up Assembly {Includes Items 10 through 13}
10)	-----	Knock Up Holder, Right
11)	-----	Knock Up Pad
12)	-----	Knock Up Holder, Left
13)	-----	Knock Up Plate
14)	-----	Extension Spring
15)	7K10890	Media Unit Clutch {Includes Items 16 through 19}
16)	-----	Clutch Hub
17)	-----	Clutch Spring
18)	-----	Clutch Collar
19)	-----	Pick Up Gear
20)	-----	Media Unit Pick Up Assembly {Includes Items 21 through 31}
21)	-----	Knock Up Cam
22)	-----	Paper Guide Roll
23)	-----	E-Ring
24)	32E14350	Paper Feed Guide
25)	130E09080	Pick Up Rubber
26)	-----	Pick Up Housing
27)	-----	Knock Up Cam, Right
28)	-----	Pick Up Shaft Pin
29)	-----	Feed Idler Shaft
30)	22E23240	Feed Roller, Left
31)	-----	Pick Up Shaft
32)	-----	Shaft Lock Bushing
A)	600K72020	Hardware Kit



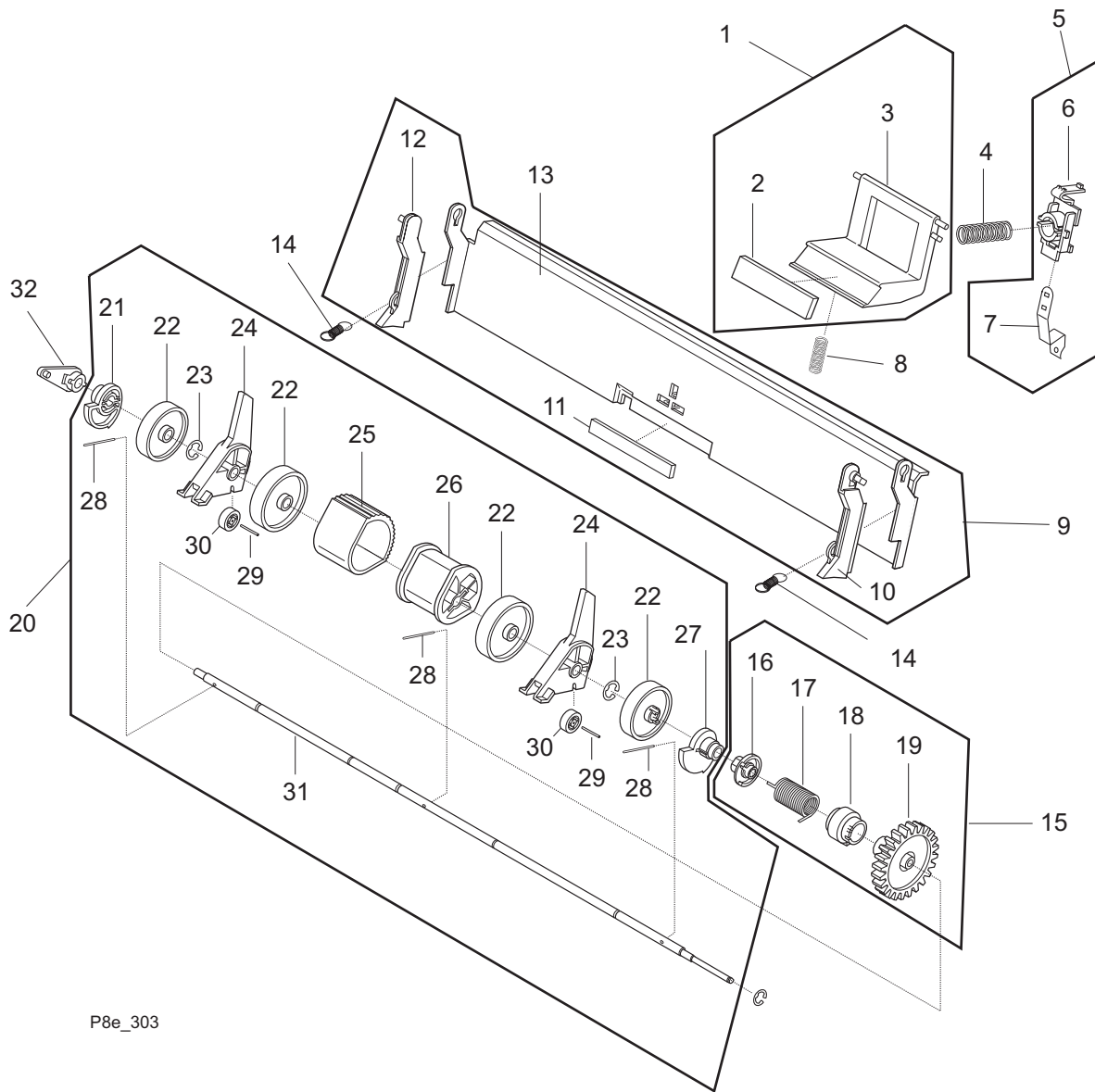

P8e\_303

## PL 5 Paper Transport

Item	Part Number	Description
1)	22K64020	Media Frame Support Unit {Includes Items 2 through 6}
2)	-----	Feed Rubber
3)	-----	Idler Feed Shaft
4)	-----	Feed Shaft Bearing
5)	-----	Feed Spring
6)	-----	Feed Support Frame
7)	-----	Media Feed Gear Unit
8)	120E19120	Paper Empty Actuator
9)	695E58680	Paper Separator
10)	130K64640	Paper Empty Assembly
A)	600K72020	Hardware Kit

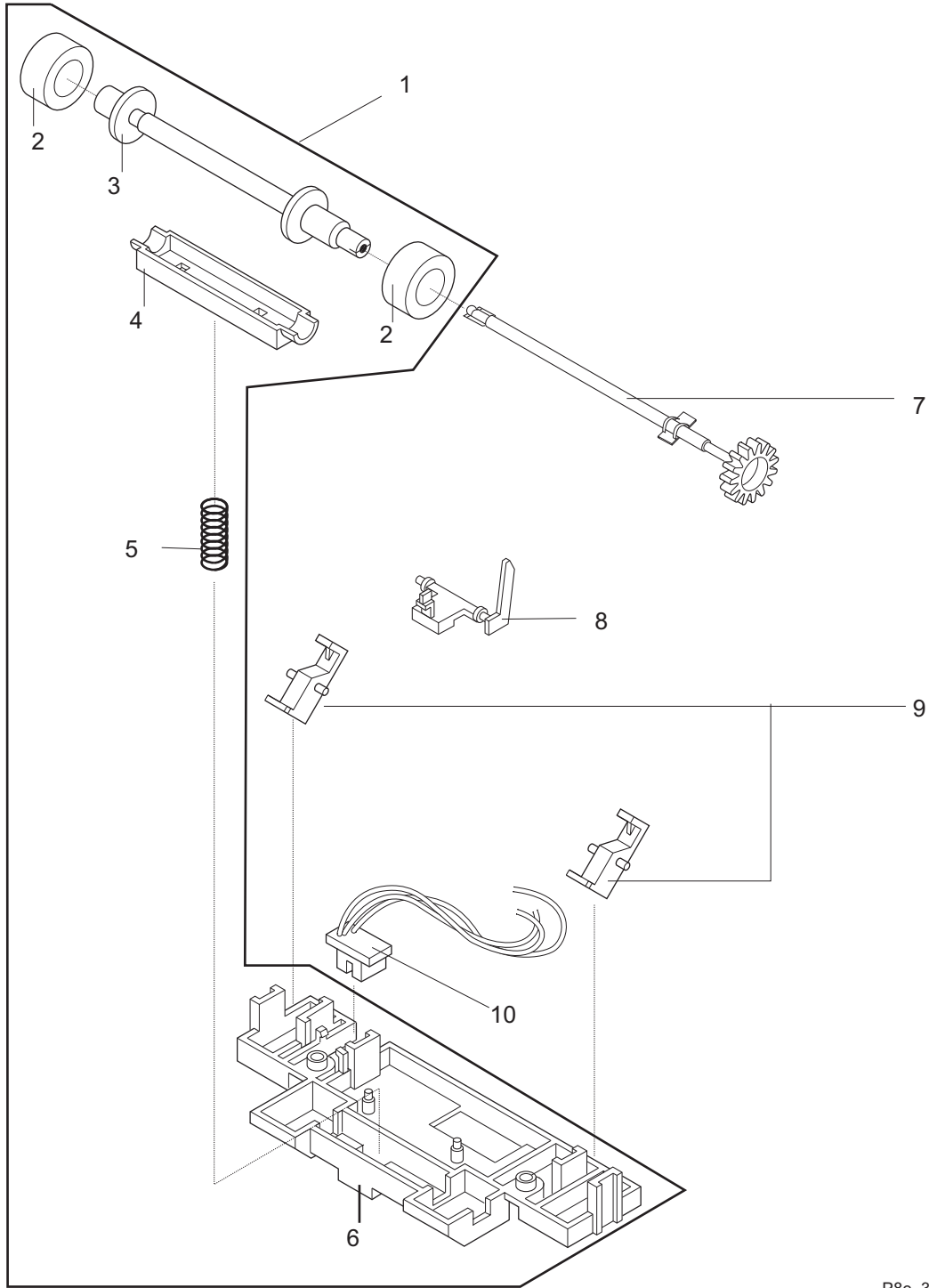

P8e\_304

## PL 6 Frame Assembly (1 of 2)

Item	Part Number	Description
1)	62K09270	LSU (Laser) Unit
2)	001K72470	Upper Frame Unit
3)	-----	Cover Open Actuator Spring
4)	-----	Cover Open Actuator
5)	-----	Cover Open Micro Switch
6)	-----	Developer Plate, Left
7)	-----	Developer Plate Spring
8)	-----	Developer Plate, Right
9)	-----	Cover Open Sensor Cover
10)	-----	Upper Frame
11)	121E15480	Paper Feed Solenoid
A)	600K72020	Hardware Kit

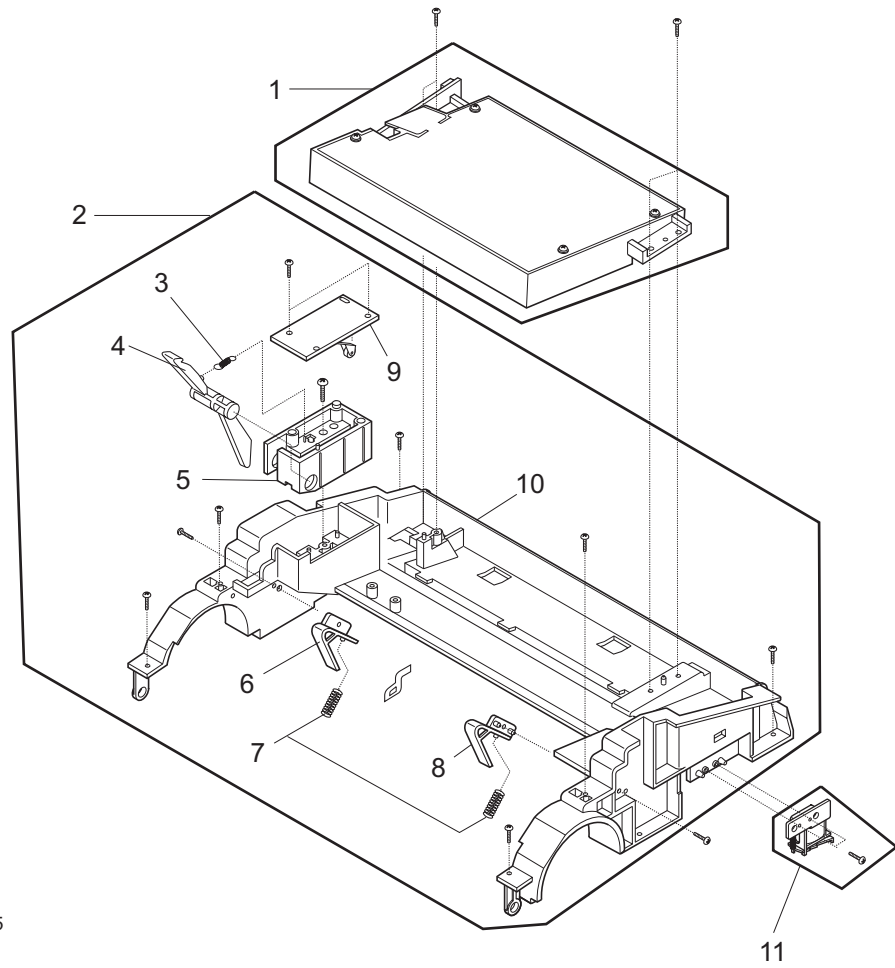

P8e\_305

## PL 7 Frame Assembly (2 of 2)

Item	Part Number	Description
1)	22E23250	Transfer Roller
2)	19K04780	Transfer Unit Holder {Includes Items 3, 4, & 5}
3)	-----	Transfer Roller Bushing
4)	-----	Transfer Roller Spring
5)	-----	Transfer Roller Holder
6)	-----	Media Unit Operator, Left {Includes Items 7 & 8}
7)	-----	Pad Holder, Left
8)	-----	Separator Pad, Left
9)	-----	Media Unit Operator, Right {Includes Items 10 & 11}
10)	-----	Separator Pad, Right
11)	-----	Pad Holder, Right
12)	007E59210	Transfer Gear
13)	15K39960	Lower Frame Unit
14)	-----	Base Frame
15)	-----	
16)	-----	
17)	-----	
18)	-----	
19)	-----	Rubber Foot
20)	-----	
21)	-----	Saw Plate
22)	-----	Saw Plate Holder
23)	130E09090	Feed Sensor Assembly
24)	120E19130	Exit Actuator
25)	101E19690	Fuser Cover
26)	-----	Transfer Roller Terminal Unit {Includes Items 27 & 28}
27)	-----	High Voltage Shaft, Large
28)	-----	High Voltage Spring, Large
29)	-----	High Voltage Terminal Unit
30)	-----	High Voltage Shaft, Small
31)	-----	Developer Unit Fuse {Includes Items 32, 33, & 34}
32)	108K00690	Developer Unit Fuse Contact, Upper
33)	-----	Developer Unit Fuse Plate
34)	-----	Developer Unit Fuse Contact, Lower
35)	-----	Off / On Switch
36)	38K12830	ELA Unit-PTL
37)	-----	
38)	-----	
39)	-----	
40)	127E12600	DC Fan Motor
A)	600K72020	Hardware Kit

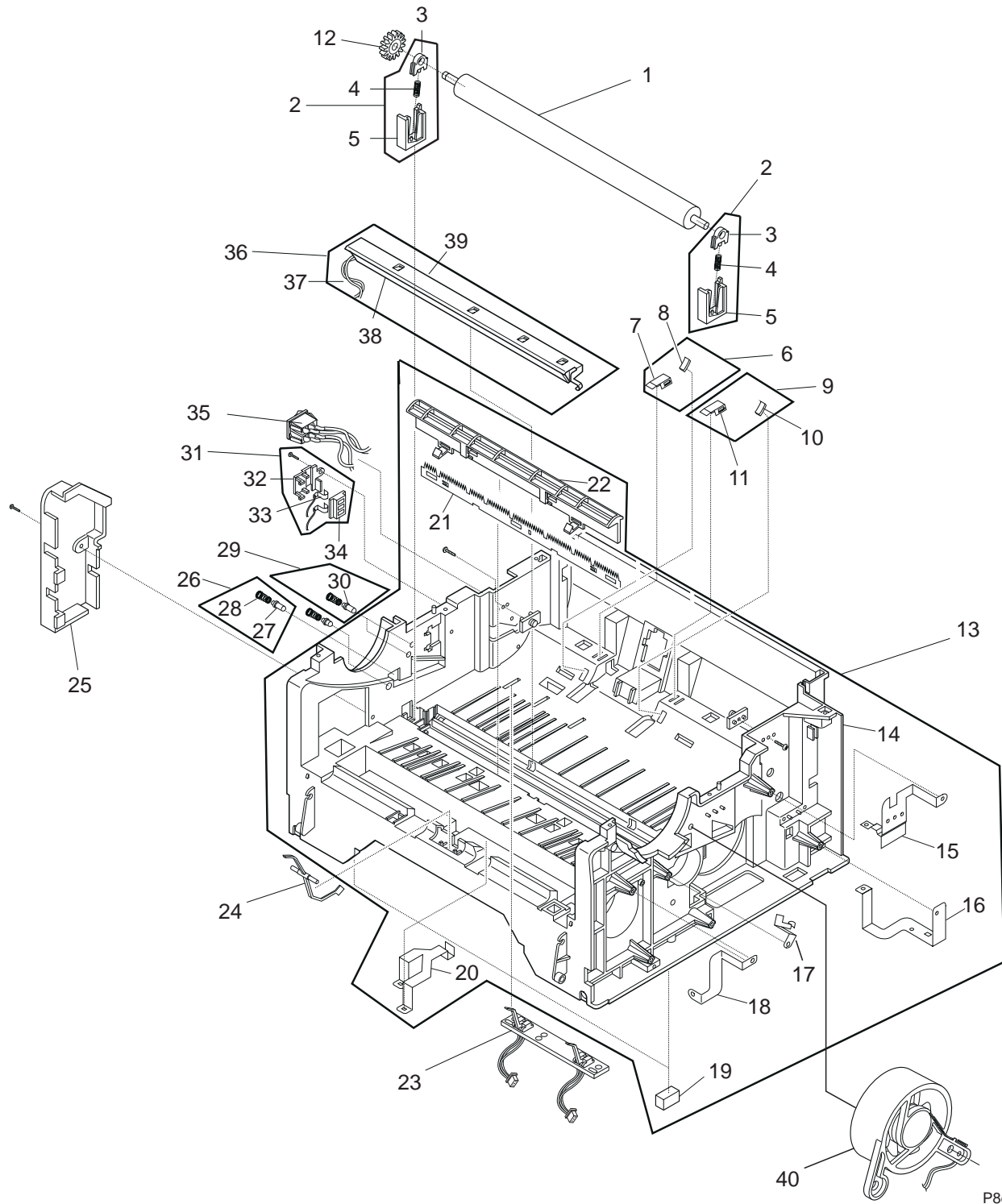

P8e\_306a

# PL 8 Fuser

Item	Part Number	Description
1)	126K12920	Fuser Unit Assembly (115 VAC) {Includes Items 2 through 19}
	126K12970	Fuser Unit Assembly (220 VAC) {Includes Items 2 through 19}
2)	-----	Rubber Exit Roller
3)	-----	Exit Bearing
4)	-----	Exit Gear
5)	-----	Roller
6)	-----	Fuser Cover
7)	-----	AC Electrode, Left
8)	-----	AC Electrode, Right
9)	-----	Thermostat
10)	-----	Fuser Frame
11)	-----	Bracket
12)	130E09100	Thermistor
13)	-----	Bracket
14)	-----	Exit Spring
15)	122E02490	Halogen Lamp (115 VAC)
	122E02480	Halogen Lamp (220 VAC)
16)	-----	Heat Roll Bearing, Left
17)	-----	Heat Roller
18)	-----	Heat Roll Bearing, Right
19)	-----	Fuser Gear
20)	9K01910	Pressure Roller Holder Assembly {Includes Items 21, 22, & 23}
21)	-----	Pressure Roller Bearing
22)	-----	Pressure Roller Bearing Holder
23)	-----	Pressure Roller Bearing Spring
24)	126K12890	Pressure Roller
25)	17E09150	Exit Roller Assembly {Includes Items 26, 27, 28, & 29}
26)	-----	Rubber Exit Roll F/Up
27)	-----	Exit Shaft F/Up
28)	-----	Exit Gear
29)	115E06360	Exit Shaft Bushing - TX
A)	600K72020	Hardware Kit



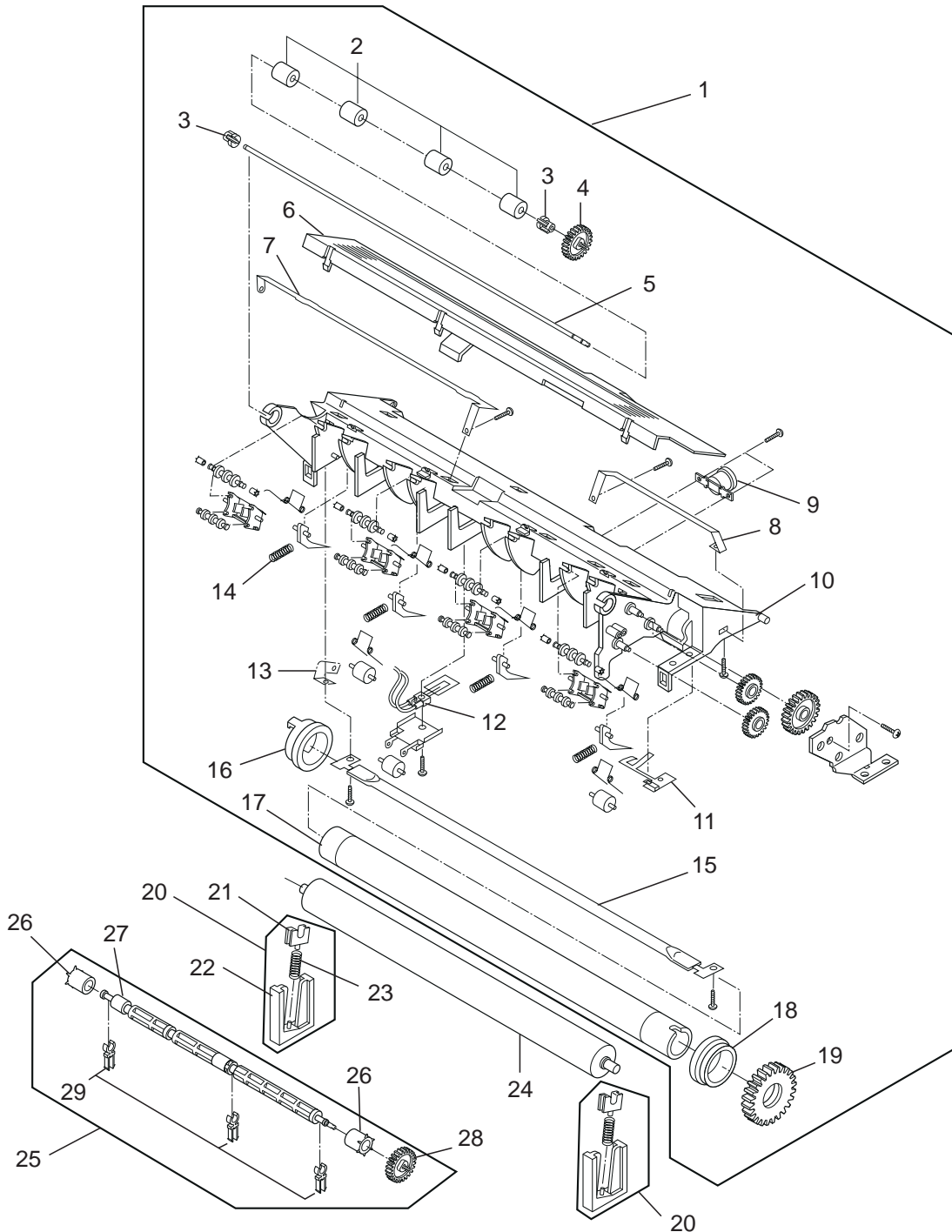

P8e\_307a

## PL 9 Main Drive Motor

Item	Part Number	Description
1)	127K30150	Main Drive Motor Assembly {Includes Items 2 through 12}
2)	-----	Main Drive Motor
3)	-----	Motor bracket
4)	-----	Motor Drive Gear
5)	-----	Feed Drive Gear
6)	-----	Gear Bracket
7)	-----	Gear-Drive 1
8)	-----	Gear-Drive 2
9)	-----	Gear-Pulley
10)	-----	RCT-Belt Impeller
A)	600K72020	Hardware Kit

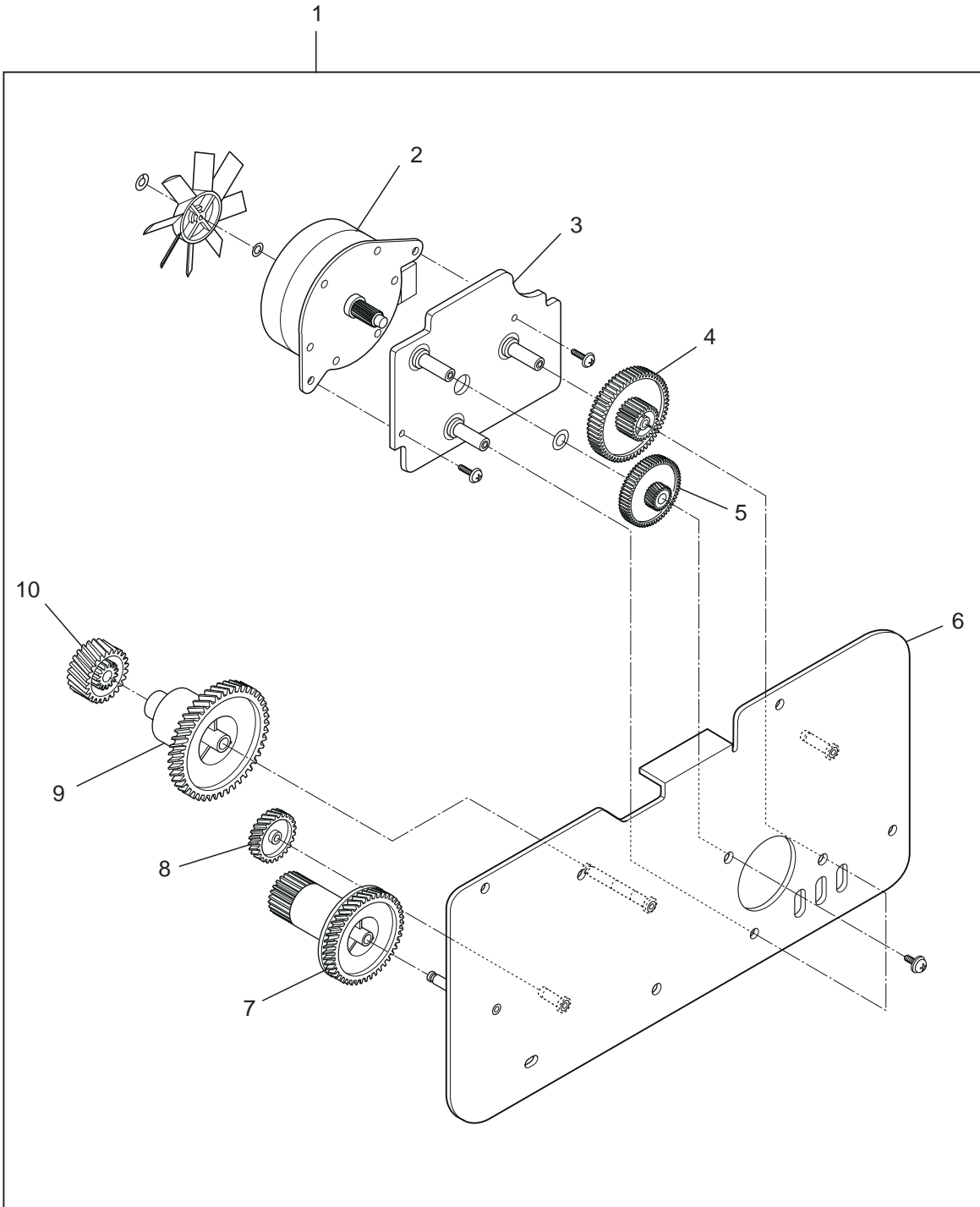

P8e\_309a

## PL 10 Electronics

Item	Part Number	Description
1)	160K60070	High Voltage Power Supply PWB
2)	114E15570	AC Plug Assembly
3)	160K60060	Controller PWB (115 VAC)
	160K55520	Controller PWB (220 VAC)
4)	-----	SIMM 4MB
	-----	SIMM 8MB
	-----	SIMM 16MB
	-----	SIMM 32MB
5)	160K55660	Engine Controller PWB (115 VAC)
	160K55510	Engine Controller PWB (220 VAC)
6)	007K11190	Joint PWB
7)	108E05380	Fuse (115 VAC / T8A)
	108E05390	Fuse (220 VAC / T5A)
A)	600K72020	Hardware Kit

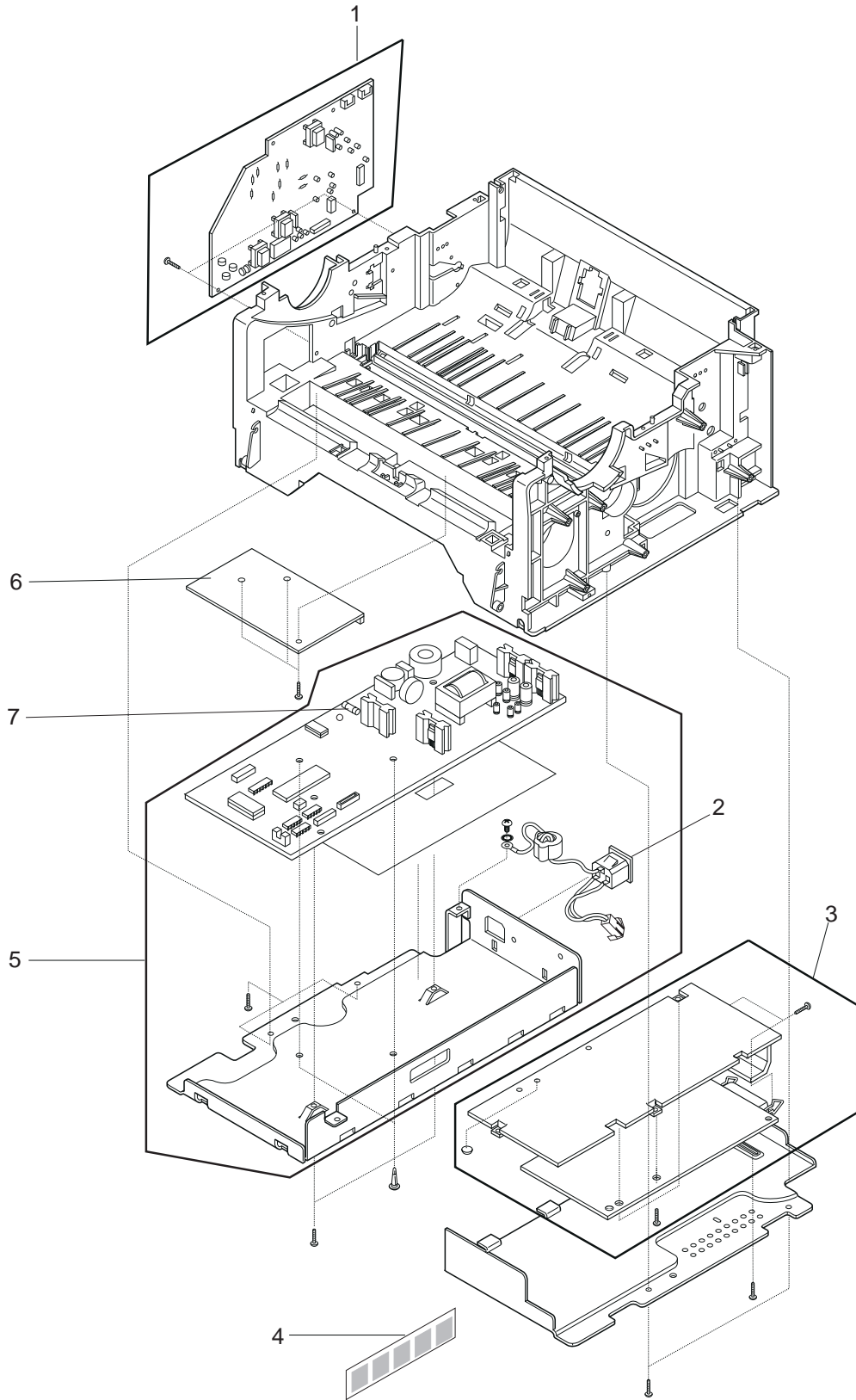

P8e\_310a

## Notes