

EPSON

TM-J2100(013)

Page 1

REF	PART NO	DESCRIPTION	SPEC	QTY
101	1062174	LOGO PLATE,AB		2
102	1062490	SWITCH PANEL UNIT,BA		1
103	1055708	COVER,ROLL PAPER,AA		1
104	1055709	TABLE,PAPER EJECTION,AA		1
105	1055710	CASE,FRONT,AA		1
106	1055711	COVER,CARTRIDGE,AA		1
107	1055712	CASE,MAIN,AA		1
108	1055713	COVER,CUTTER,AA		1
109	1055716	GUIDE,TABLE,AA		1
111	1055718	FRAME,CIRCUIT BOARD,A		1
112	1055719	COVER,I/F		1
113	1055720	COVER,CIRCUIT BOARD,A		1
114	1055721	PLATE,SUPPORT,A		1
115	1061077	SEAL,CAUTION,C		1
116	X610220000	HEXAGON SCREW	MM	2
117	2035492	INTERCONNECTION CIRCUIT BOARD ASS'Y,AA	TM-J2000	1
118	2035506	FFC,I/F INTERCONNECTION CIRCUIT BOARD		1
119	1055714	COVER,BACK,AA		1
120	1038983	COVER,POWER SWITCH,BA		1
121	1055245	MAINTENANCE CARTRIDGE UNIT		1
122	1057738	128B HEAD ASP UNIT		1
123	1061002	MECHANISM ASS'Y,BB		1
124	1055722	LABEL,OPERATION,AA		1
126	1061079	GASKET,A		2
SI	B302404211	C.P.S.(O) SCREW	M3X6	14
201	2048006	MAIN CIRCUIT BOARD UNIT,AB	,	1
202	2033907	RS-232 I/F CIRCUIT BOARD UNIT,BB	,	1
501	1017364	HOLDER,N.E.DETECTOR		1
502	1019914	GEAR,TRANSMISSION		2
503	1020228	SPACER,N.E,DETECTOR		1
504	1026984	TAPE,FFC COVER		1
505	1032390	CABLE CRAMP		3
506	1055357	ROLLER,TENSION		1
507	1055358	ROLLER,PAPER HOLD		1
508	1055360	O-RING,TUBE HOLD		2
509	1055368	SPRING,PAPER HOLD		1
510	1055369	SPRING,123		2
511	1055392	FRAME,TUBE GUIDE		1
512	1055395	GEAR,TENSION ROLLER		1
513	1055400	GUIDE,ROLL PAPER		1
514	1055401	HOLDER,ROLL PAPER		1
515	1055402	LEVER,N.E.DETECT		1
516	1055403	HOLDER,PLATEN		1
517	1055431	SPRING,SLIDER		1
518	1055439	PLATEN		1
519	1055442	LEVER,ROLL PAPER		1
520	1055443	PLATE,COVER		1
521	1055453	FIXED BLADE		1
522	1055457	NUT,TUBE		2
523	1055467	SHAFT,PAPER HOLD ROLLER		2
524	1055470	SHAFT,COVER		1
525	1055477	SHAFT,HOLDER,ROLL PAPER		1
526	1055479	SHAFT,LINK		1

EPSON

TM-J2100(013)

Page 2

REF	PART NO	DESCRIPTION	SPEC	QTY
527	1055480	SHAFT, LINK, B		1
528	1055648	LINK, FRAME FRONT SUB ASS'Y		1
529	1055649	LINK, FRAME BACK SUB ASS'Y		2
532	1056085	SHEET, ROLL PAPER		1
533	2011867	MICROSWITCH	1,30V,0.1A,	1
534	2035349	PHOTO MICRO SENSOR		1
535	2035353	FPC, HEAD		1
536	2035358	CONNECTOR, H.P.	...	1
537	2035359	CONNECTOR, N.E.DETECT	...	1
538	2035505	POWER SWITCH ASS'Y, AA		1
539	C109302051	DETECTOR ADJUSTMENT SCREW		1
540	C732211010	PRINT SHAFT HOLDER		2
541	Y583001013	RUBBER STAND	199-1708	2
542	1055652	PUMP UNIT		1
543	1055651	PUMP ASS'Y		1
544	2035356	MOTOR, PUMP	,	1
545	1041153	EARTH PLATE, CARRIAGE MOTOR		2
547	1055356	BUSH, CARRIAGE MOTOR		4
548	1055364	SPRING, BELT TENSION		1
549	1055365	SPRING, GUIDE SHAFT, R		1
550	1055366	SPRING, GUIDE SHAFT, L		1
551	1055384	BELT, CARRIAGE		1
552	1055386	SLIDE BEARING, PAPER FEED		1
553	1055391	PULLEY, CARRIAGE TRANSMIT		1
554	1055398	GEAR, TRANSMIT		1
555	1055404	LEVER, PAPER DETECT		2
556	1055461	SHAFT, CARRIAGE GUIDE		1
557	1055462	SHAFT, SUB CARRIAGE GUIDE		1
558	1055654	CARRIAGE, TRANSMIT PULLEY SUB ASS'Y		1
559	1055656	HEAD, CARRIAGE SUB ASS'Y		1
560	1055658	FRAME, FRONT SUB ASS'Y		1
561	1055659	PAPER FEED, ROLLER SUB ASS'Y		1
562	1057254	GROUND PLATE, MOTOR		1
563	1056082	SPRING, GUIDE SHAFT, TENSION		1
564	1056083	INSULATOR, PF MOTOR		4
565	1056084	TAPE, TRANSMIT GEAR		1
566	1056086	SPRING, PAPER DETECT		2
567	2035354	MOTOR, CARRIAGE	,	1
568	2035355	MOTOR, PAPER FEED	,	1
569	2035357	CONNECTOR, MOTOR	...	1
570	2035360	CONNECTOR, PAPER DETECT	...	1
571	1055393	GEAR, PAPER FEED		1
572	1056028	CARTRIDGE, HOLDER UNIT, BA		1
573	2035349	PHOTO MICRO SENSOR		2
574	2047503	CONNECTOR, IC DETECT, 2	...	1
575	1056031	INK, SUPPLY UNIT, BA		1
576	1055664	CUTTER UNIT		1
577	1055456	EMERGENCY CUTTER		1
578	1055666	CUTTER, FRAME ASS'Y		1
579	1055667	CUTTER, COVER SUB UNIT		1
580	1036006	GEAR, DETECTION A/C		1
581	1036010	SHAFT, DETECTION GEAR A/C		1

EPSON

TM-J2100(013)

Page 4

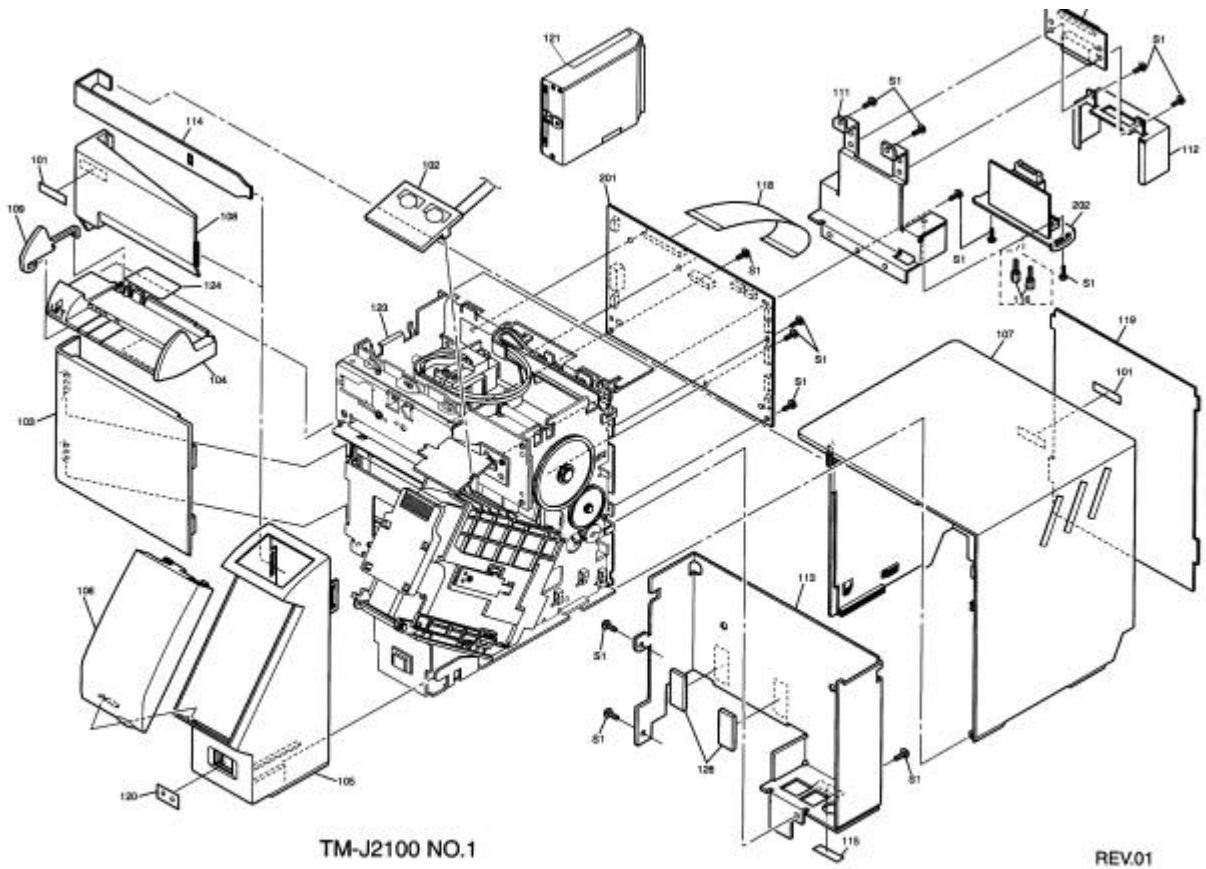

EPSON

TM-J2100(013)
Page 5

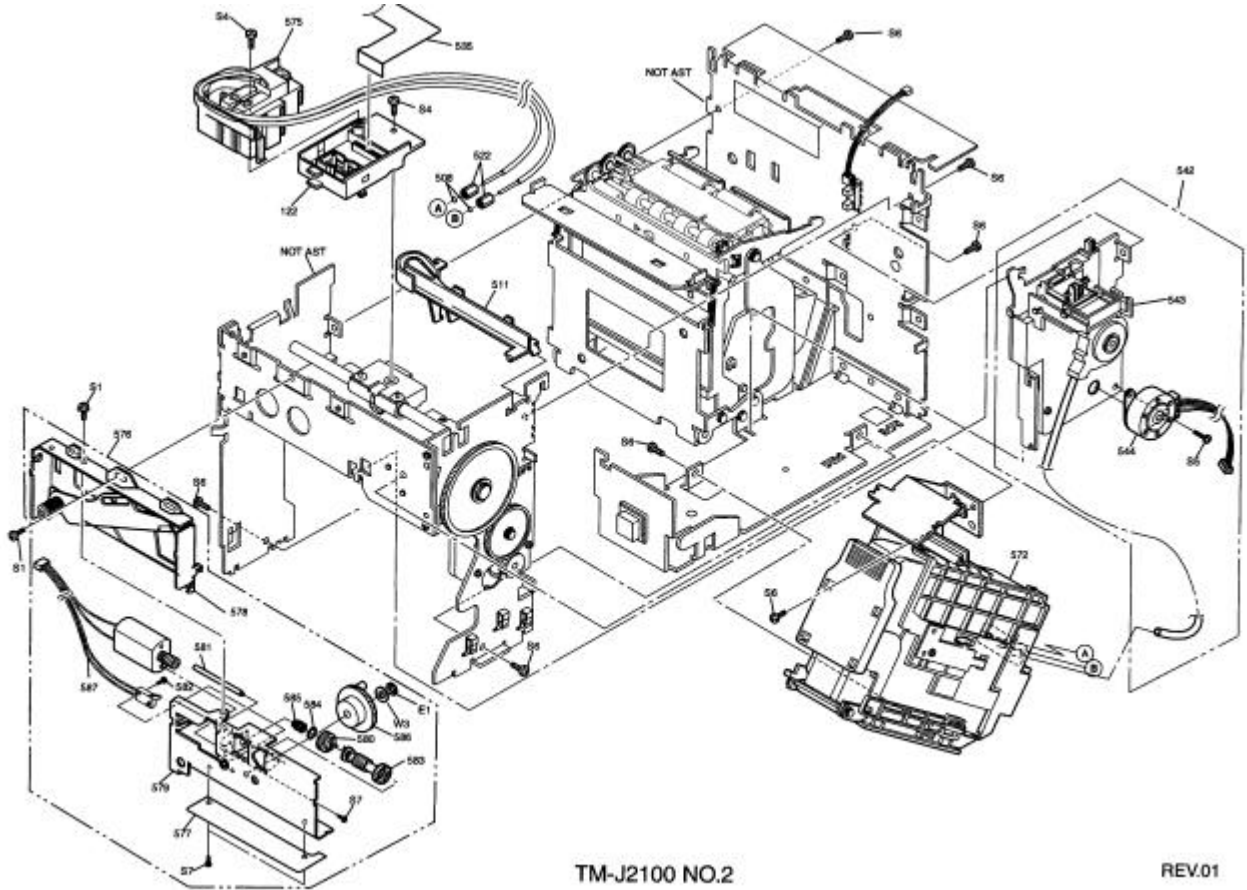

TM-J2100 NO.2

REV.01

EPSON

TM-J2100(013)

Page 6

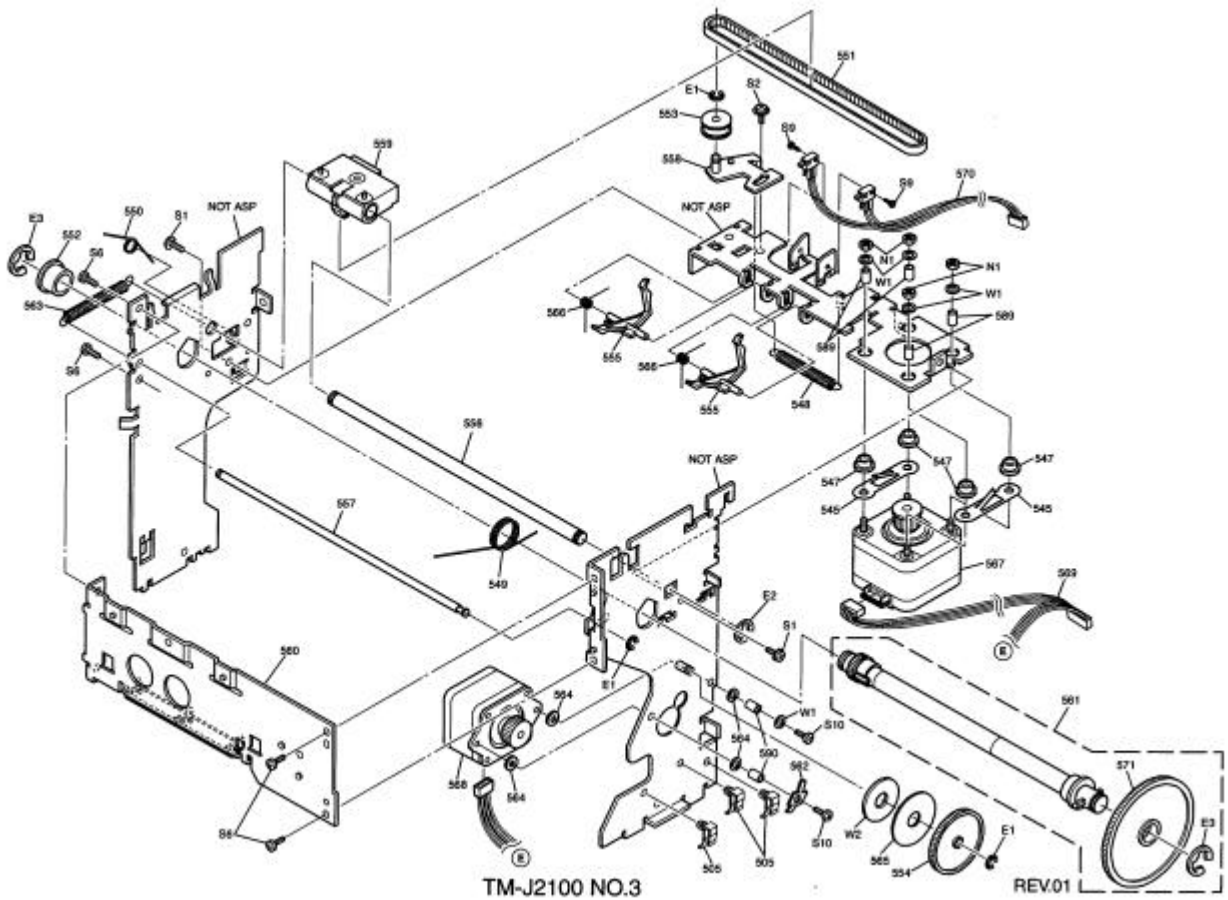

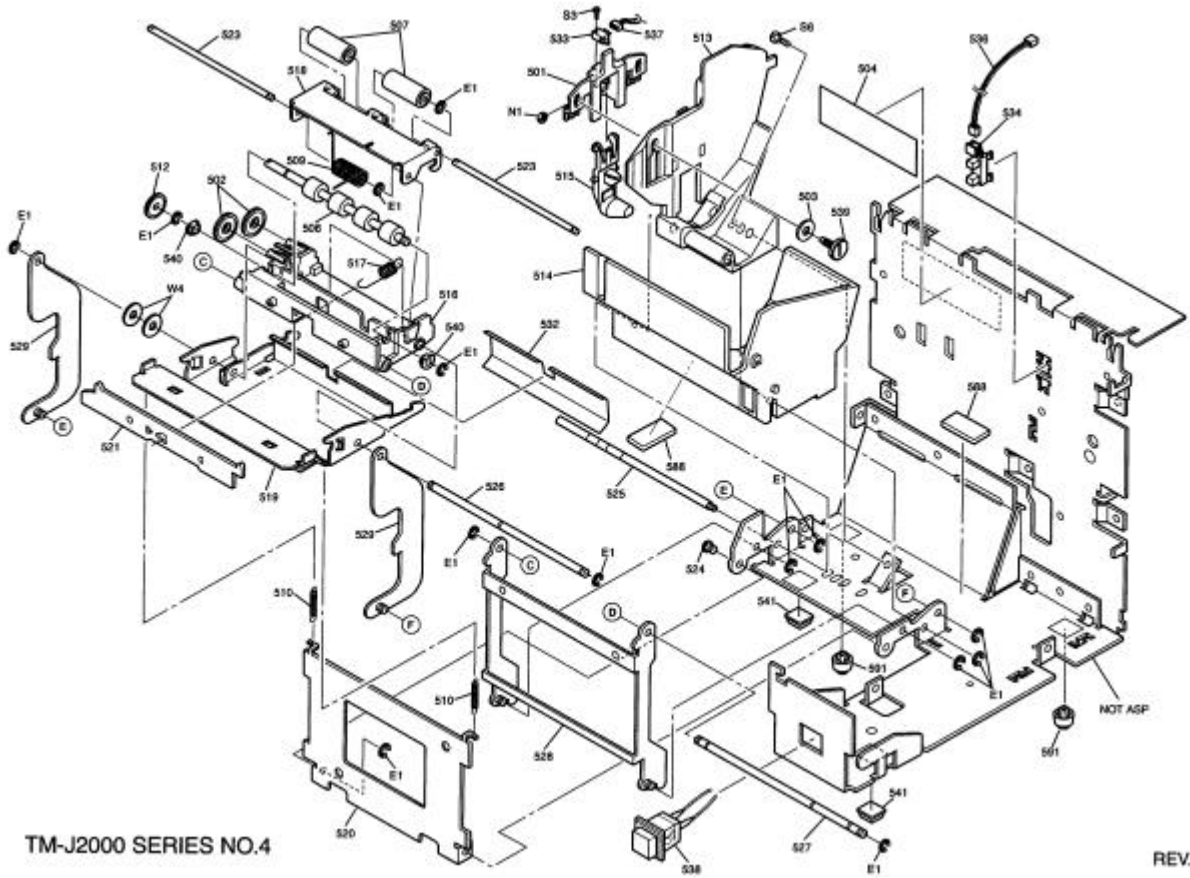

TM-J2000 SERIES NO.4

REV.01

EPSON

TM-J2100(013)

Page 8

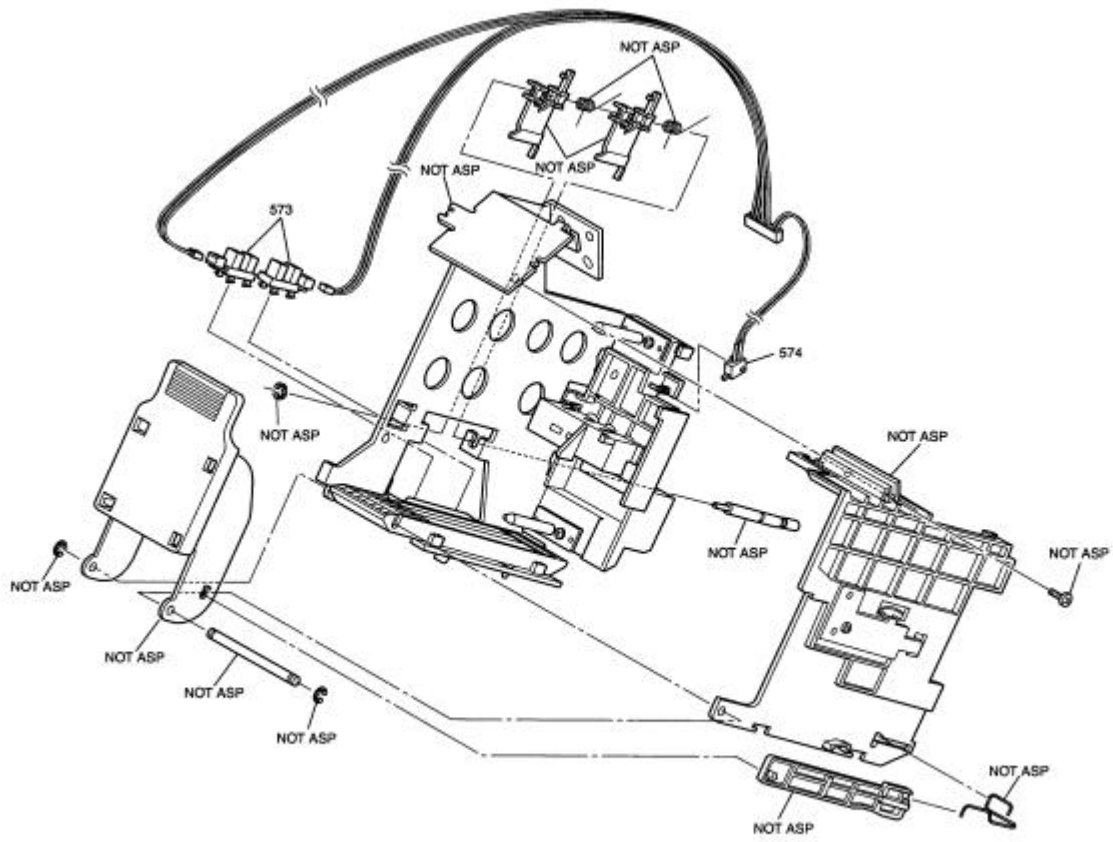

TM-J2100/J2100P NO.5

REV.01