

**SAMSUNG**

**Digital Laser MFP**  
**SF-830/SF-835P**  
**Msys830/Msys835P**  
**ML-920**

***SERVICE*** **MANUAL**

**Digital Laser MFP**

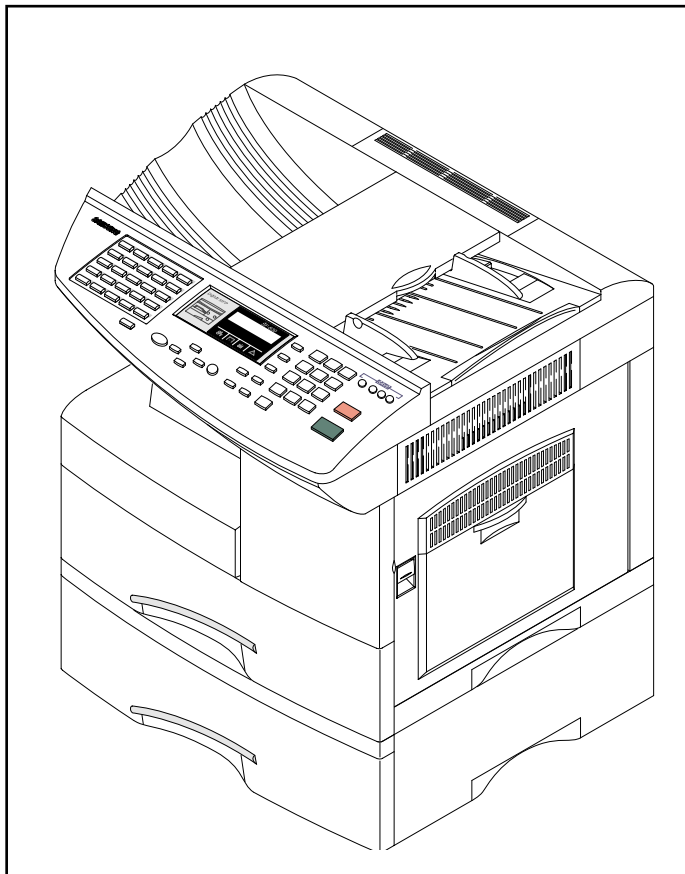

**Contents**

- 1. Precautions**
- 2. Specifications**
- 3. Disassembly**
- 4. Troubleshooting**
- 5. Exploded Views and Parts List**
- 6. Block Diagram**
- 7. Connection Diagram**
- 8. Dual Line Option**



**ELECTRONICS**

This service manual is also provided on the web,  
the ITSELF system Samsung Electronics Co., Ltd.  
“<http://itself.sec.samsung.co.kr>”

© Samsung Electronics Co.,Ltd. JUNE 2002  
Printed in Korea.  
VERSION NO. : 1.01      CODE : JC-0069A

- This Service Manual is a property of Samsung Electronics Co.,Ltd.  
Any unauthorized use of Manual can be punished under applicable  
international and/or domestic law. -



**This manual is stated and provided for service description.**

.....  
All rights reserved. Any parts of the information in this manual are prohibited from free duplication, use or translation without prior written approval except in cases allowed by the Copyright Act. Specifications are subject to change without prior notice.

**Samsung Electronics Digital Printing CS Group**  
Copyright (c) 2002. 6.

# Contents

---

<b>1. Precautions</b> .....	<b>page(1-1)</b>
1-1 Safety Precautions .....	page(1-1)
1-2 ESD Precautions.....	page(1-2)
1-3 Super Capacitor or Lithium Battery Precautions .....	page(1-2)
1-4 Tools for Troubleshooting.....	page(1-3)
<b>2. Specifications</b> .....	<b>page(2-1)</b>
2-1 General Specifications .....	page(2-1)
2-2 Printer Specifications (SF-835P Only) .....	page(2-2)
2-3 Facsimile Specification.....	page(2-2)
2-4 Scanner Specification .....	page(2-3)
2-5 Copy Specification.....	page(2-3)
2-6 Telephone Specification .....	page(2-4)
2-7 Consumables .....	page(2-4)
<b>3. Disassembly and Reassembly</b> .....	<b>page(3-1)</b>
3-1 General Precautions on Disassembly .....	page(3-1)
3-2 Cover Rear Ass'y .....	page(3-2)
3-3 Rear Cover .....	page(3-2)
3-4 Scanner Ass'y .....	page(3-3)
3-5 OPE Ass'y .....	page(3-4)
3-6 ADF Upper Ass'y.....	page(3-5)
3-7 Guide Lower Ass'y .....	page(3-6)
3-8 Housing Lower Ass'y.....	page(3-7)
3-9 Side Cover Ass'y page(3-9)	
• MP-Tray .....	page(3-9)
• Duplex Ass'y .....	page(3-10)
• Transfer Roller Ass'y .....	page(3-10)
3-10 Fuser Ass'y.....	page(3-11)
3-11 Exit Ass'y.....	page(3-12)
3-12 Cover Paper Exit Ass'y .....	page(3-13)
3-13 Drive Ass'y .....	page(3-14)
3-14 SMPS .....	page(3-15)
3-15 LSU .....	page(3-16)
3-16 Main Frame Ass'y.....	page(3-17)
• Cover Exit Rear .....	page(3-18)
• MP Ass'y .....	page(3-19)
• Feed Ass'y .....	page(3-20)
• Pick Up Ass'y .....	page(3-20)
• Main PBA.....	page(3-21)
3-17 SCF Ass'y .....	page(3-22)

<b>4. Maintenance &amp; Troubleshooting .....</b>	<b>page(4-1)</b>
4-1 Preventative Maintenance .....	page(4-1)
4-2 Error Messages .....	page(4-2)
4-3 User Mode .....	page(4-4)
4-4 Tech Mode .....	page(4-5)
4-4-1 How to Enter Service Mode .....	page(4-5)
4-4-2 Setting-up System in Tech Mode .....	page(4-6)
4-4-3 SYSTEM DATA .....	page(4-7)
4-4-4 MEMORY CLEAR .....	page(4-7)
4-4-5 MAINTENANCE .....	page(4-8)
4-4-6 REPORT/HELP .....	page(4-11)
4-4-7 Firmware Upgrade .....	page(4-12)
4-4-7-1 Local Machine .....	page(4-12)
4-4-7-2 Remote FAX .....	page(4-12)
4-5 Identify Sale Date .....	page(4-13)
4-6 ENGINE TEST MODE .....	page(4-14)
4-6-1 To enter the Engine Test Mode .....	page(4-14)
4-6-2 Diagnostc .....	page(4-14)
4-6-3 ENGINE PRINT .....	page(4-14)
4-7 Troubleshooting .....	page(4-15)
4-7-1 Print Quality .....	page(4-15)
• Abnormal Image Printing and Defective Roller .....	page(4-17)
• No Image .....	page(4-18)
• All Black .....	page(4-20)
• Vertical White Line (Band) .....	page(4-21)
• Dark Image .....	page(4-22)
• Background .....	page(4-23)
• Ghost .....	page(4-24)
• Black Dot .....	page(4-25)
• Horizontal Band .....	page(4-26)
• Irregular Density .....	page(4-27)
• White Spot .....	page(4-28)
• Trembling at the End When OHP Printing .....	page(4-29)
• Poor Fusing Grade .....	page(4-30)
4-7-2 Malfunction .....	page(4-31)
• No Power (LCD NO display LED Off) .....	page(4-33)
• Fuser Error .....	page(4-34)
• Paper Jam (Mis-Feeding) .....	page(4-35)
• Paper Jam(Jam 1) .....	page(4-36)
• Engine Error .....	page(4-37)
4-7-3 Toner Cartridge and Drum Cartridge Service .....	page(4-38)
4-7-3-1 Signs and Measures at Poor toner cartridge .....	page(4-39)
4-7-4 The cause and solutions of bad environment of the software .....	page(4-42)

---

4-7-4-1 The printer is not working (1) .....	page(4-42)
4-7-4-2 The printer is not working (2) .....	page(4-42)
4-7-4-3 Abnormal Printing .....	page(4-43)
4-7-4-4 SPOOL Error .....	page(4-43)

## **5. Exploded View & Parts List ..... page(5-1)**

5-1 Main Exploded View & Parts List .....	page(5-2)
5-2 Scanner Ass'y Exploded View & Parts List .....	page(5-5)
5-3 ADF UpperAss'y Exploded View & Parts List.....	page(5-7)
5-4 Scan Lower Ass'y Exploded View & Parts List.....	page(5-9)
5-5 Side Cover Ass'y Exploded View & Parts List.....	page(5-12)
5-6 OPE Ass'y Exploded View & Parts List .....	page(5-14)
5-7 Cassette Ass'y Exploded View & Parts List .....	page(5-16)
5-8 Exit Ass'y Exploded View & Parts List.....	page(5-18)
5-9 Feeder Ass'y Exploded View & Parts List .....	page(5-20)
5-10 MP Ass'y Exploded View & Parts List .....	page(5-22)
5-11 Base Frame Exploded View & Parts List.....	page(5-24)
5-12 Pick-up Ass'y Exploded View & Parts List.....	page(5-25)
5-13 Drive Ass'y Exploded View & Parts List .....	page(5-26)
5-14 Main Frame Ass'y Exploded View & Parts List.....	page(5-28)
5-15 Fuser Ass'y Exploded View & Parts List .....	page(5-30)
5-16 SCF Ass'y Exploded View & Parts List .....	page(5-32)
5-17 Screw .....	page(5-34)

## **6. Block Diagrams ..... page(6-1)**

## **7. Connection Diagram ..... page(7-1)**

## **8. Dual Line Option..... page(8-1)**

8-1 Introduction .....	page(8-1)
8-1-1 Master Board Role .....	page(8-1)
8-1-2 Slave Board Role .....	page(8-1)
8-2 Specification.....	page(8-1)
8-3 Dual Line Board Connector Pin Assignment.....	page(8-2)
8-4 Troubleshooting of Dual Line Board .....	page(8-3)
8-4-1 Troubleshooting Flow Chart .....	page(8-3)
8-4-2 Dual Line Board error.....	page(8-3)
8-4-3 Modem interface error.....	page(8-4)
8-4-4 LIU interface error .....	page(8-5)

# 1. Precautions

---

Follow these safety, ESD, and servicing precautions to prevent personal injury and equipment damage.

## 1-1 Safety Precautions

---

1. Be sure that all built-in protective devices are in place. Restore any missing protective shields.
2. Make sure there are no cabinet openings through which people-particularly children- might insert fingers or objects and contact dangerous voltages.
3. When re-installing chassis and assemblies, be sure to restore all protective devices, including control knobs and compartment covers.
4. Design Alteration Warning:Never alter or add to the mechanical or electrical design of this equipment, such as auxiliary connectors, etc. Such alterations and modifications will void the manufacturer's warranty.
5. Components, parts, and wiring that appear to have overheated or are otherwise damaged should be replaced with parts which meet the original specifications. Always determine the cause of damage or overheating, and correct any potential hazards.
6. Observe the original lead dress, especially near sharp edges, AC, and high voltage power supplies. Always inspect for pinched, out-of-place, or frayed wiring. Do not change the spacing between components and the printed circuit board.
7. Product Safety Notice:Some electrical and mechanical parts have special safety-related characteristics which might not be obvious from visual inspection. These safety features and the protection they provide could be lost if a replacement component differs from the original. This holds true, even though the replacement may be rated for higher voltage, wattage, etc.
8. Components critical for safety are indicated in the parts list with symbols . ▲ ▲  
Use only replacement components that have the same ratings, especially for flame resistance and dielectric specifications. A replacement part that does not have the same safety characteristics as the original may create shock, fire, or other safety hazards.

## 1-2 ESD Precautions

---

1. Certain semiconductor devices can be easily damaged by static electricity. Such components are commonly called “Electrostatically Sensitive (ES) Devices”, or ESDs. Examples of typical ESDs are: integrated circuits, some field effect transistors, and semiconductor “chip” components.

The techniques outlined below should be followed to help reduce the incidence of component damage caused by static electricity.

**CAUTION** : Be sure no power is applied to the chassis or circuit, and observe all other safety precautions.

2. Immediately before handling a semiconductor component or semiconductor-equipped assembly, drain off any electrostatic charge on your body by touching a known earth ground. Alternatively, employ a commercially available wrist strap device, which should be removed for your personal safety reasons prior to applying power to the unit under test.
3. After removing an electrical assembly equipped with ESDs, place the assembly on a conductive surface, such as aluminum or copper foil, or conductive foam, to prevent electrostatic charge buildup in the vicinity of the assembly.
4. Use only a grounded tip soldering iron to solder or desolder ESDs. Use only an “anti-static” solder removal device. Some solder removal devices not classified as “anti-static” can generate electrical charges sufficient to damage ESDs.
5. Do not use Freon-propelled chemicals. When sprayed, these can generate electrical charges sufficient to damage ESDs.
6. Do not remove a replacement ESD from its protective packaging until immediately before installing it. Most replacement ESDs are packaged with all leads shorted together by conductive foam, aluminum foil, or a comparable conductive material.
7. Immediately before removing the protective shorting material from the leads of a replacement ESD, touch the protective material to the chassis or circuit assembly into which the device will be installed.
8. Maintain continuous electrical contact between the ESD and the assembly into which it will be installed, until completely plugged or soldered into the circuit.
9. Minimize bodily motions when handling unpackaged replacement ESDs. Normal motions, such as the brushing together of clothing fabric and lifting one’s foot from a carpeted floor, can generate static electricity sufficient to damage an ESD.

## 1-3 Super Capacitor or Lithium Battery Precautions

---

1. Exercise caution when replacing a super capacitor or Lithium battery. There could be a danger of explosion and subsequent operator injury and/or equipment damage if incorrectly installed.
2. Be sure to replace the battery with the same or equivalent type recommended by the manufacturer.
3. Super capacitor or Lithium batteries contain toxic substances and should not be opened, crushed, or burned for disposal.
4. Dispose of used batteries according to the manufacturer’s instructions.

## 1-4 Tools for Troubleshooting

The following tools are recommended for safe and smooth troubleshooting described in this service manual.

### 1 DVM(Digital Volt Meter)

Standard: Indicates more than 3 digits.

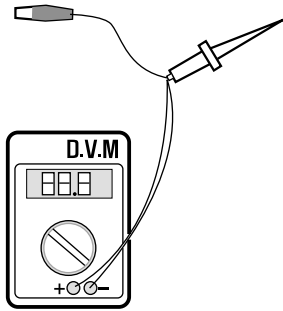

### 3 Driver

Standard: "-" type, "+" type (M3 long, M3 short, M2 long, M2 short).

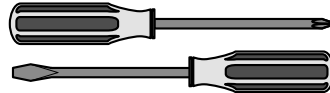

### 4 Pinset

Standard: For general home use, small type.



### 2 Electronic Scale

Standard: Equipment to check the weight of consumables(toner cartridge) supplied by Samsung Electronics. (The gram unit can be measured.)

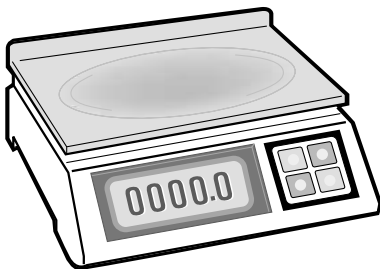

### 5 Cotton Swab

Standard: For general home use, for medical service.



### 6 Cleaning Equipments a IPA(Isopropyl Alcohol)dry cloth or a soft stuff neutral detergent.

### 7 Software(Driver) installation CD ROM

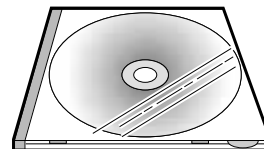

**Note** : Mind your hands not to be touched when you disassemble and reassemble PBA ASS'Y, such as the main board, SMPS, HVPS.

## 2. Specification

---

Specifications are correct at the time of printing. Product specifications are subject to change without notice. See below for product specifications.

### 2-1 General Specifications

---

Item	Description
Type of Unit	Desktop
Operation System	Win95/98/ME/ NT /2000/XP
Duplex Printing	Yes(Default)
Interface	IEEE1284(Nibbel/ECP)
	USB(without HUB mode)
CPU	66 MHz(KS32C61200)
Emulation	PCL6 (SF-835P Only)
Warming up Time	41 Sec (Stand-By), 25°C
Absolute Storage Condition	Temperature : -20°C ~ 40°C, Humidity : 10% RH ~ 95% RH
Operating Condition	Temperature : 10°C ~ 32°C, Humidity : 20% RH ~ 80 % RH
Recommended Operating Condition	Temperature : 16°C ~ 30°C, Humidity : 30% RH ~ 70% RH
Dimension(W X D X H)	560 X 433 X 459 mm (22.0 X 17.0 X 18.1 inches)
Weight	About 22.5 Kg(with CRU)
Acoustic Noise	Less than 56/47 dB(Copy/Printing mode)
Power Rating	AC 100VAC ~ 127VAC ± 15 %, 50/60Hz ± 3Hz AC 220VAC ~ 240VAC ± 15 % , 50/60Hz ± 3Hz
Power Consumption	Avg. 320Wh ( No load Condition)
Power Save Consumption	Avg. 25Wh
Recommended System Requirement	Pentium II 233 Mhz, 64 MB RAM, 120MB(Hard Disk)
Minimum System Requirement	Pentium II 400Mhz, 128 MB RAM, 220MB(Hard Disk)
LCD	16 characters X 2 lines
Memory	4 Mbyte for flash Memory , 20 Mbyte for DRAM

## 2-2 Printer Specifications (SF-835P Only)

Item	Description
Printing Method	Laser Scanning Unit + Electro Photography
Speed	Single Side : 12 PPM (Letter Size, 5% Character Pattern)
	Duplex : 7.5 IPM/Images/Min) (Letter Size, 5% Character Pattern)
Source of Light	LSU(Laser Scanning Unit)
Duplex Printing	Yes(Default)
Resolution(Horizontal X Vertical)	True 600 X600 DPI , 1200 DPI Class
Feed Method	Cassette Type , By Pass Tray, ADF(Automatic Document Feeder)
Feed Direction	FISO(Front-In Side-Out)
Paper Capacity(Input)	Cassette : 550 Sheets By Pass Tray : 100 Sheets(based on 75g/β≥, 20lb)
Paper Capacity(Output)	Face Down : 250 Sheets
Effective Print Width	203 ± 1mm (8 inch)

## 2-3 Facsimile Specification

Item	Description
Standard Recommendation	ITU-T Group3(ITU : International Telecommunications Union)
Application Circuit	PSTN or behind PABX (PSTN : Public Switched Telephone Network. PABX : Private Automatic Branch Exchange)
Data coding(Compression)	MH/MR/MMR/JBIG(Transmission)
Modem speed	33600/28800/14400/12000/9600/7200/4800/2400 bps
Transmission Speed	Approximately 3 sec(33,600 bps)
Effective Scanning Width	8.2 inches(208 mm)
Halftone	256 Levels
Paper Capacity(Input)	ADF(Automatic Document Feeder) : 50Sheets(75g/β≥)
FAX Mode	Standard /Fine/Super Fine
Memory	8 MB

## 2-4 Scanner Specification

Item	Description
Type	Sheetfed(with ADF)
Speed	Mono : 1.25 msec/line, Color : 5 msec/line
Device	Color CIS (Contact Image Sensor) Module
Interface	IEEE1284(ECP Support) USB(without HUB Mode)
Compatibility	TWAIN Standard , WIA
Optical Resolution(H X V)	300 X 300 dpi
Halftone	256 Levels
Effective Scan width	8.2 inches(208 mm)

## 2-5 Copy Specification

Item	Description
Mode	B/W
Quality	Text/Photo/Mixed
Mono Copy Speed <sup>(1)</sup>	ADF (MDSP) : Text/mixed : Approx. 7 cpm : Photo : Approx. 3 cpm
Optical Resolution (H x V)	300 X 300 dpi
Multi Copy	999 pages
Maximum Original Size	Legal
Maximum Page Size	Legal
Paper Type Selection	Plain , Legal , Cardstock , Transparency
Zoom Range	ADF : 25~200 %(1% Step)

NOTE :

(1) Speed claims based on the test chart : Letter size.

SDMP : Single Document Multiple Printout

MDSP : Multiple Document Single Printout

## 2-6 Telephone Specification

---

Item	Description
1Touch Dial	50 EA(1~25 , shift key + 26~50)
Speed Dial	200 EA
Tone/Pulse	Tone only user mode Tone/Pulse selectable in tech mode.

## 2-7 Consumables

---

Item		Description
Type		Separate type (Toner Cartridge / Drum Cartridge)
Life	Toner Cartridge	6,000 sheets ( 5% coverage pattern, simplex normal mode )
	Drum Cartridge	15,000 sheets (simplex normal mode )

# 3. Disassembly and Reassembly

---

## 3-1 General Precautions on Disassembly

---

When you disassemble and reassemble components, you must use extreme caution.

The close proximity of cables to moving parts makes proper routing a must. If components are removed, any cables disturbed by the procedure must be restored as close as possible to their original positions. Before removing any component from the machine, note the cable routing that will be affected.

**Whenever servicing the machine, you must perform as follows:**

1. Check to verify that documents are not stored in memory.
2. Unplug the power cord.
3. Use a flat and clean surface.
4. Replace only with authorized components.
5. Do not force to remove or planten plastic-material components.
6. Make sure all components are in their proper position.

### 3-2 Cover Rear Ass'y

---

1. Open the Side cover.

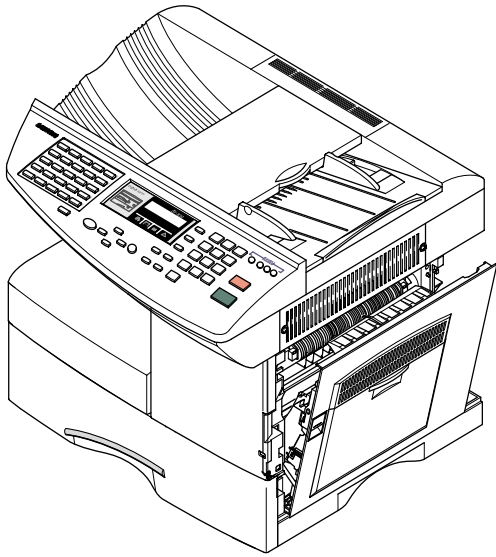

2. Remove the four screws securing the Cover Rear Ass'y.

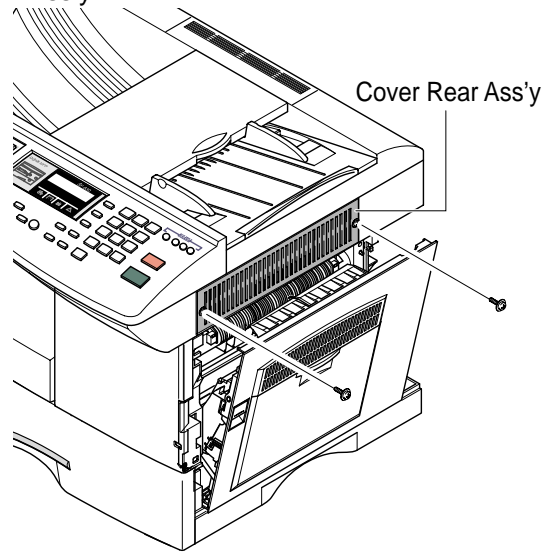

### 3-3 Rear Cover

---

1. Remove the six screws securing the Rear Cover.

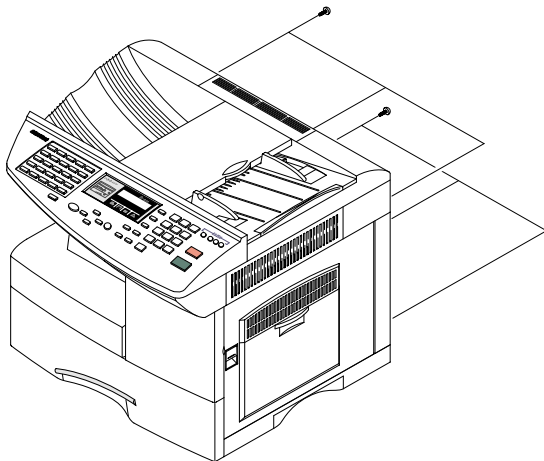

2. Separate the Rear Cover from the Base Frame and Scanner Ass'y.

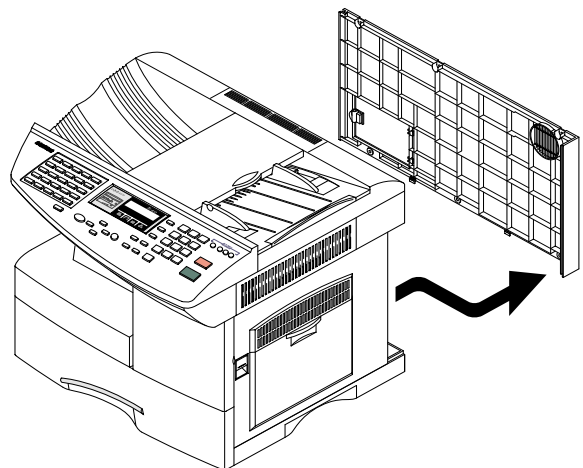

### 3-4 Scanner Ass'y

1. Before you remove the Scanner Ass'y, you should remove:
  - Cover Rear Ass'y (see page 3-2)
  - Rear Cover (see page 3-2)

2. Remove the six screws and take out the Shield Main Upper.

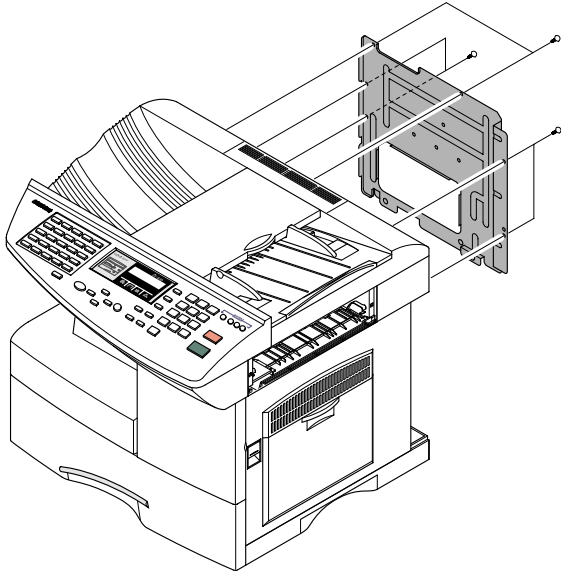

3. Remove the three screws, as shown below.

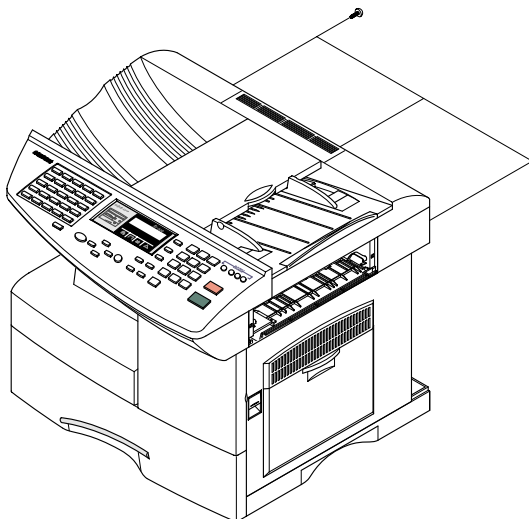

4. Open the Side Cover Ass'y first to open the Front Cover, in the other words, close the Front Cover first to Assembly it.

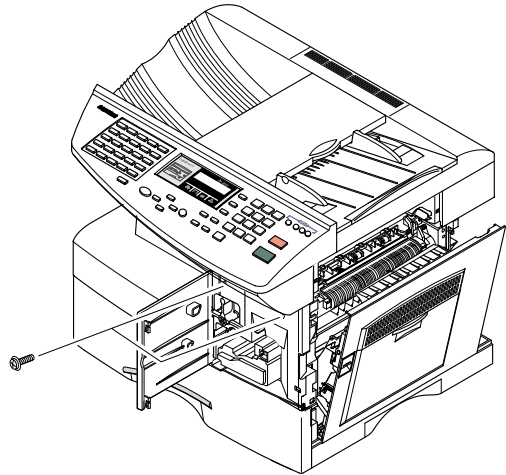

5. Unplug the one connector from the Main Board and remove two screws.

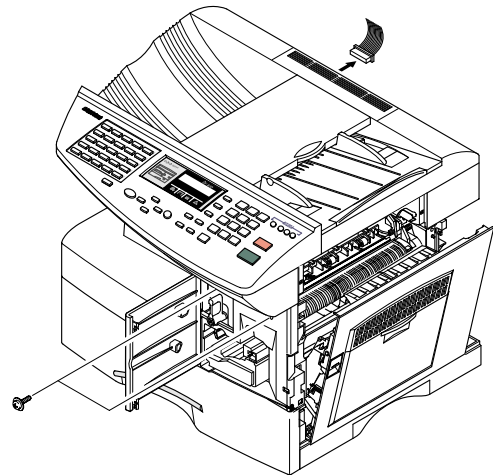

6. Pull up the Scanner Ass'y in the direction of arrow.

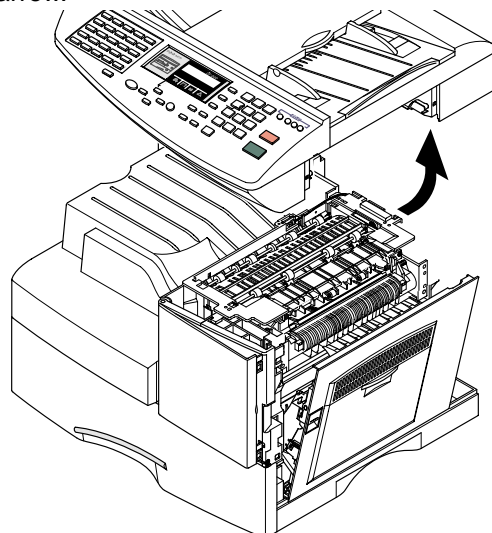

### 3-5 OPE Ass'y

1. Before you remove the OPE Ass'y, you should remove:
  - Rear Cover (see page 3-2)
  - Scanner Ass'y (see page 3-3)

2. Remove the two screws securing the Scanner Ass'y.

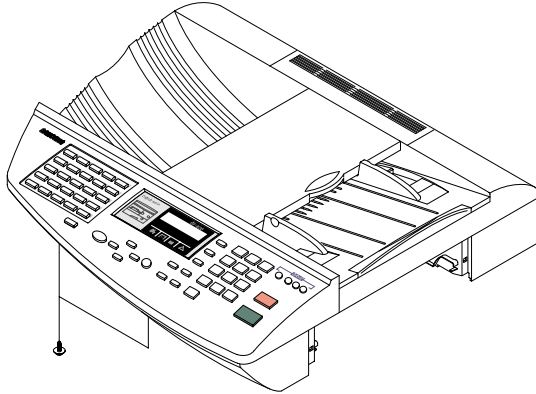

3. Pull the OPE Ass'y as shown below.

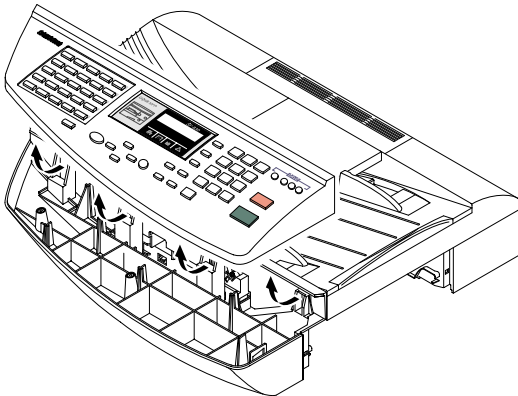

4. Unplug the two connector from the OPE Ass'y.

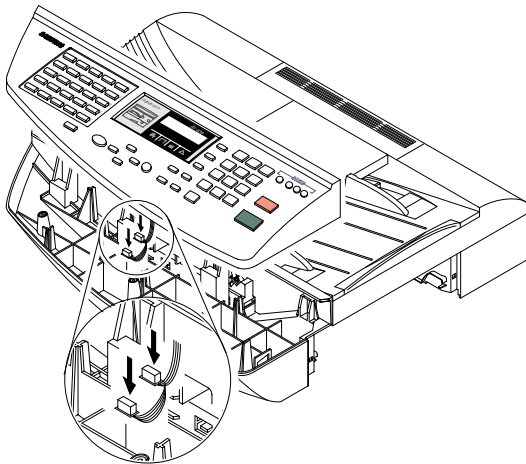

5. Remove nine screws securing the OPE PBA to the OPE Cover.

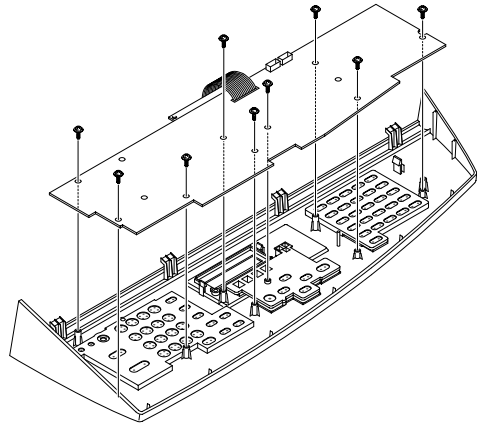

6. Remove the Contact Rubber from the unit.

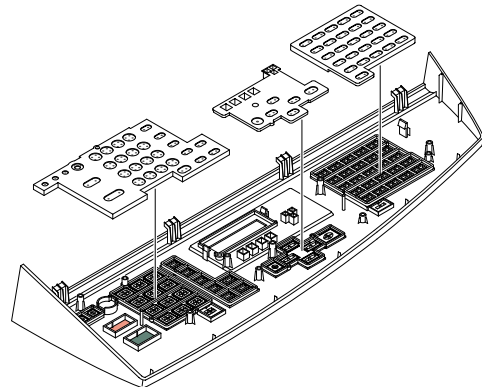

7. Remove the Key Pad from the unit.

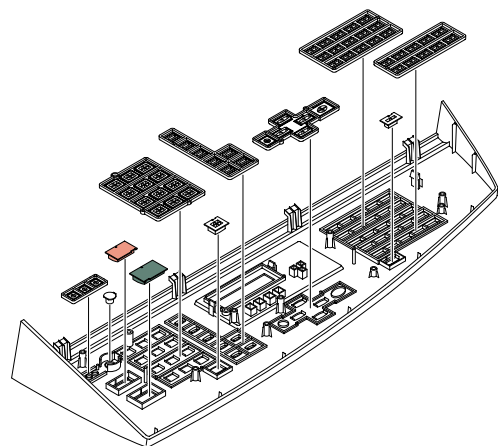

## 3-6 ADF Upper Ass'y

1. Before you remove the ADF Ass'y, you should remove:

- Rear cover (see page 3-2)
- Scanner Ass'y (see page 3-3)
- OPE Ass'y (see page 3-4)

2. Open the ADF Upper Ass'y.

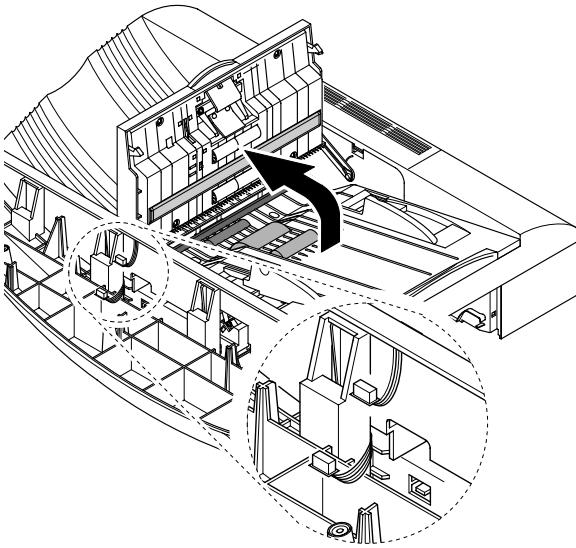

3. Remove the Ground Cable and unlatch the Link Tray from the Cover Gear, as shown below.

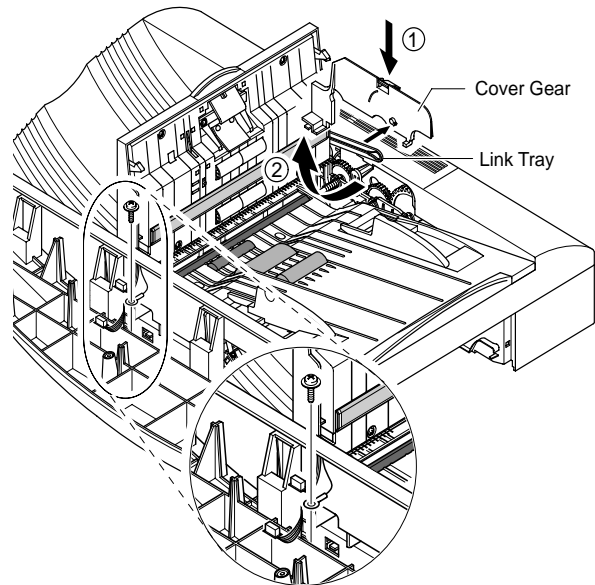

4. Remove the ADF Upper Ass'y, as shown below.

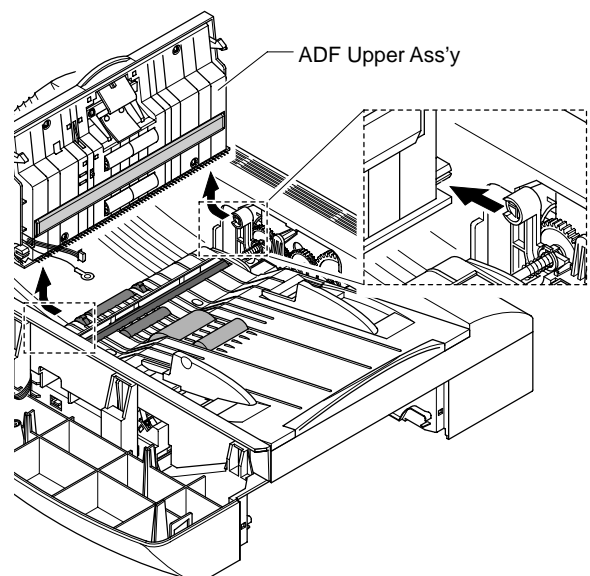

### 3-7 Guide Lower Ass'y

1. Before you remove the Guide Lower Ass'y, you should remove:
  - Rear Cover (see page 3-2)
  - Scanner Ass'y (see page 3-3)
  - OPE Ass'y (see page 3-4)
  - ADF Upper Ass'y (see page 3-5)

2. Remove the four screws securing the Guide Lower Ass'y.

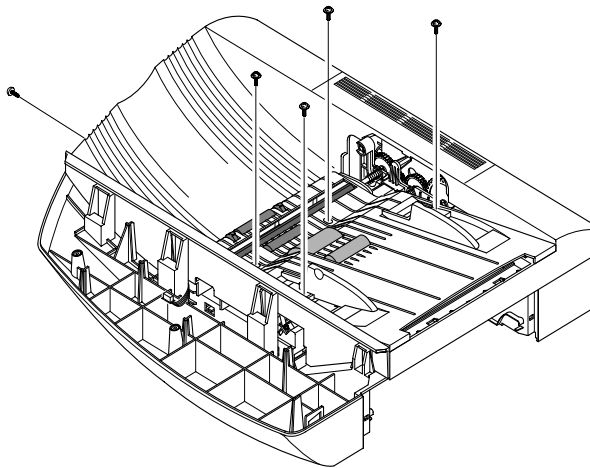

3. Push the ① part to the arrow direction (to the inner), unlatch the ② part to the arrow direction and remove Guide Lower Ass'y.

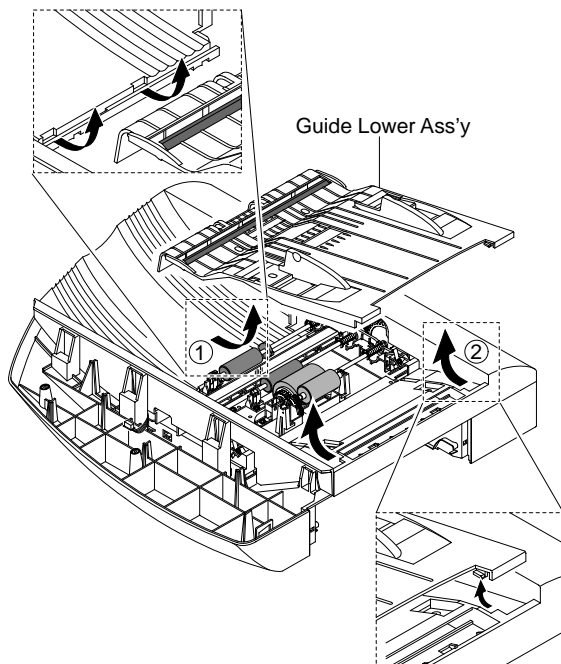

4. Pull the Input Tray and remove it.

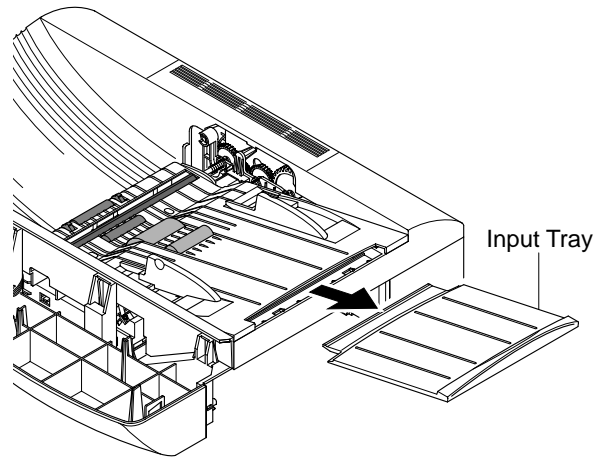

5. Take out the Housing Upper ADF, as shown below.

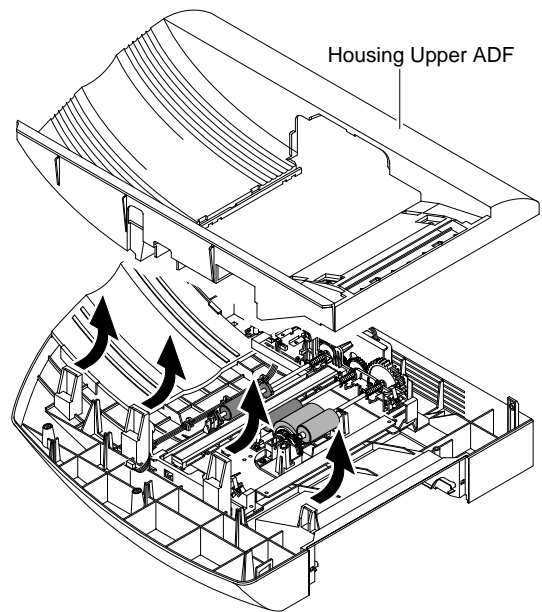

### 3-8 Housing Lower Ass'y

1. Before you remove the Housing Lower Ass'y, you should remove:
  - Rear Cover (see page 3-2)
  - Scanner Ass'y (see page 3-3)
  - OPE Ass'y (see page 3-4)
  - ADF Upper Ass'y (see page 3-5)
  - Guide Lower Ass'y (see page 3-6)

2. Unplug the two connectors and FFC Cable from the Scan Board.

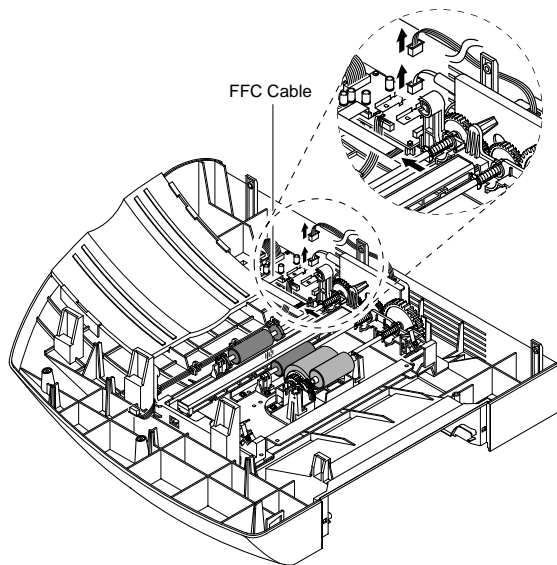

3. Remove the seven screws securing the ADF Lower Ass'y.

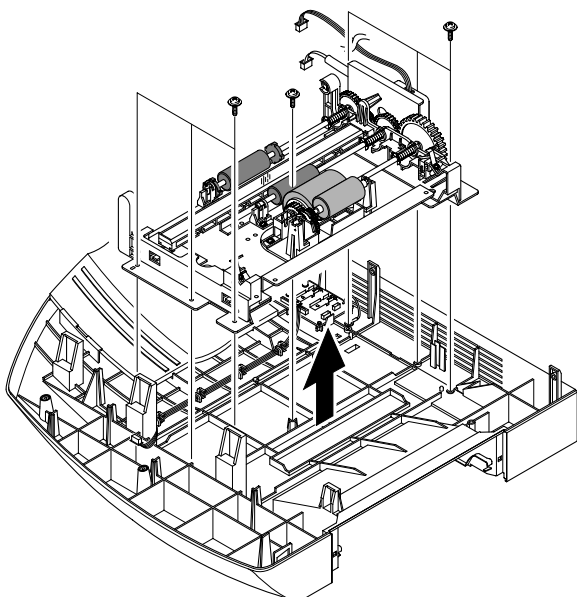

4. Unlatch the Exit Roller gear part and remove it, as shown below.

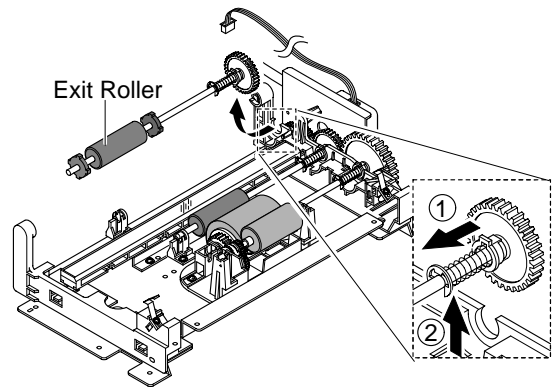

5. Unlatch the Scan Roller gear part and remove it, as shown below.

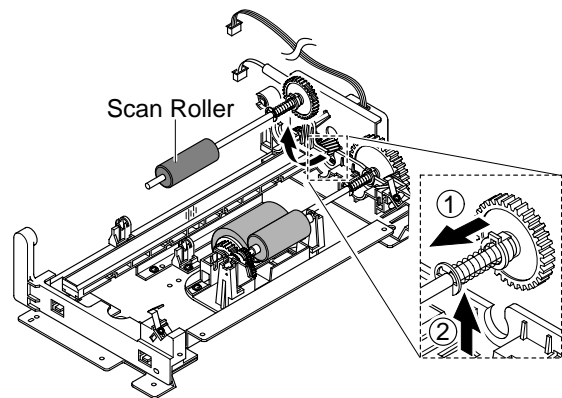

6. Unlatch the ADF Roller gear part and remove it, as shown below.

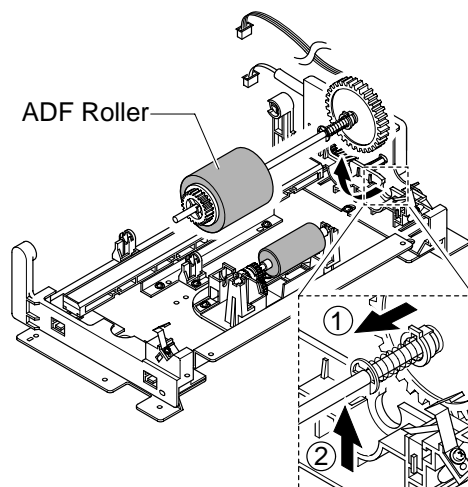

7. Pull the both side and remove the Pick up Roller, as shown below.

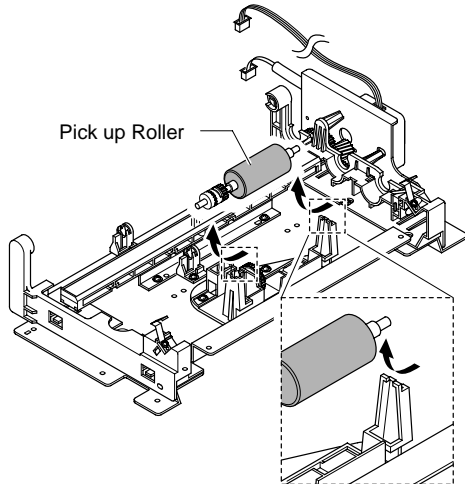

10. Remove the four screws securing the ETC Motor Ass'y and remove it.

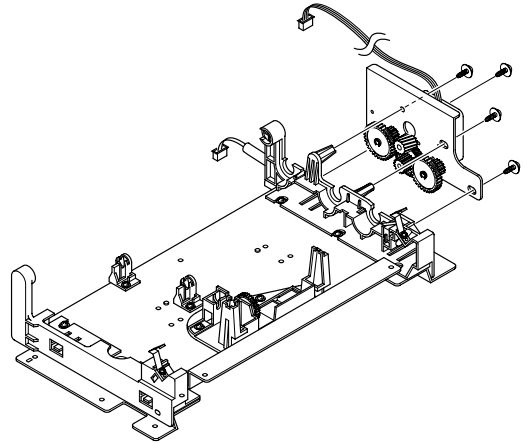

8. Remove the two screws and pull the CIS Cable. Take out the CIS Ass'y.

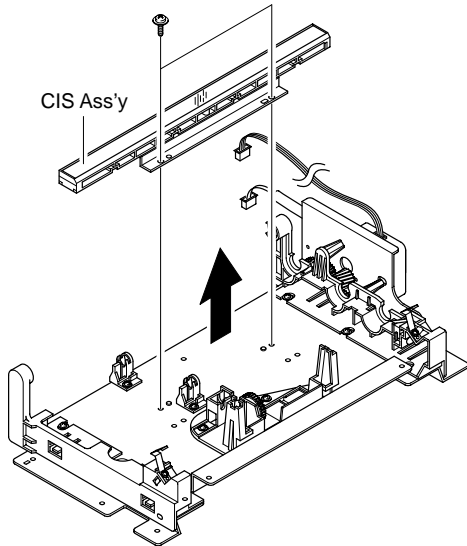

11. Unlatch the Cover Switch and remove it, as shown below.

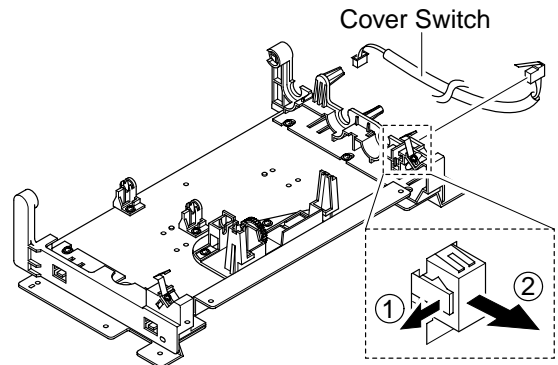

9. Remove the one screw securing the CIS Bracket and take out the CIS.

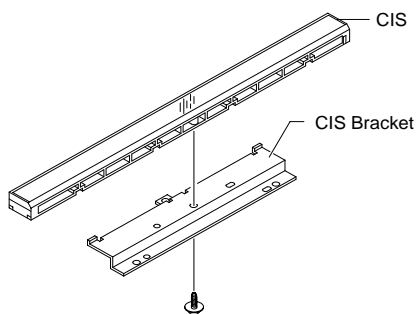

12. Unlatch the both side and remove the Scan Board.

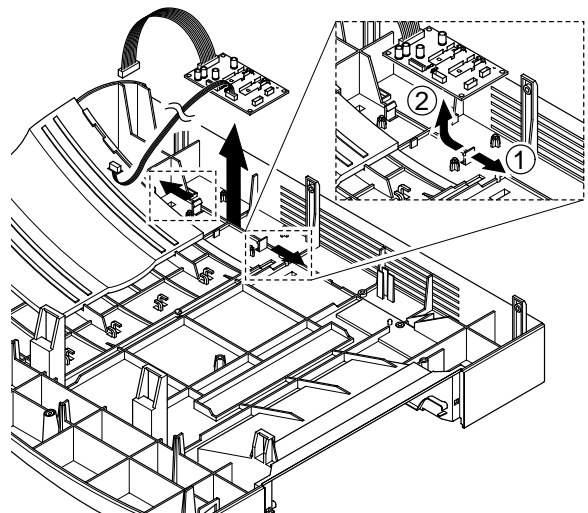

### 3-9 Side Cover Ass'y

1. Remove the two screws to release the Stopper(Main Frame side) securing the Side Cover to the Main Frame.

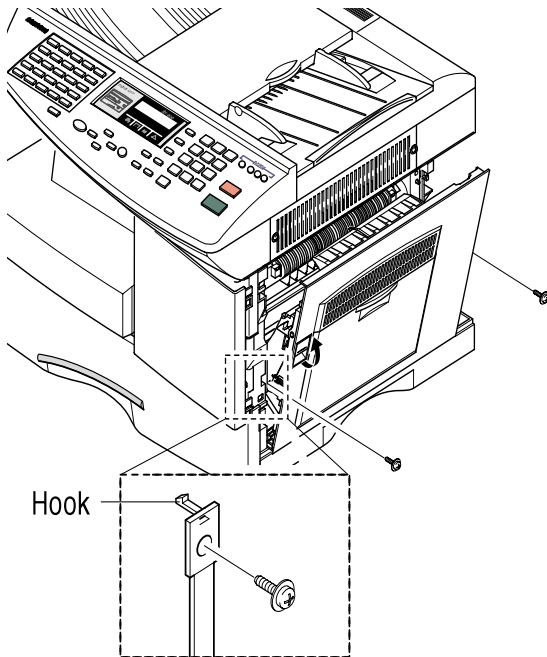

2. Completely open the Side Cover Ass'y, and after pull the ① part to the arrow direction (to the top), pull the ② part to the arrow direction (inner side)

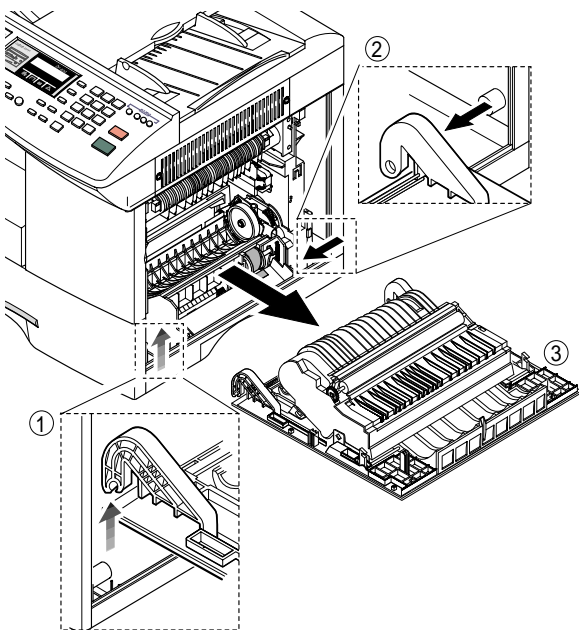

#### \* MP-Tray

1. Pull the both side of the ① part to disassemble it.

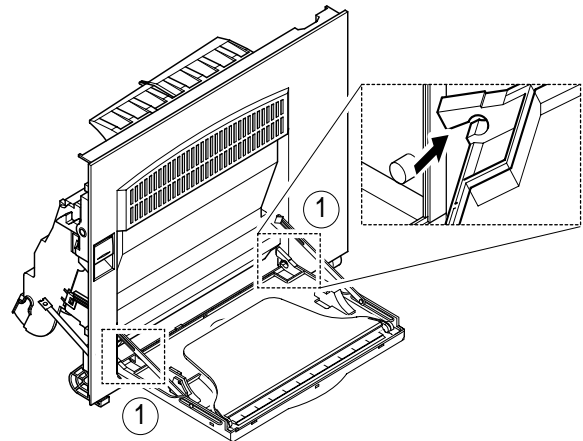

2. As the ① part, make the Tray-Case and the Tray-Link in rectangular position to disassemble the Tray-Case from the Tray Link. The Tray Link locates at an angle of 45° from the Side Cover Ass'y and then remove the Tray Link.

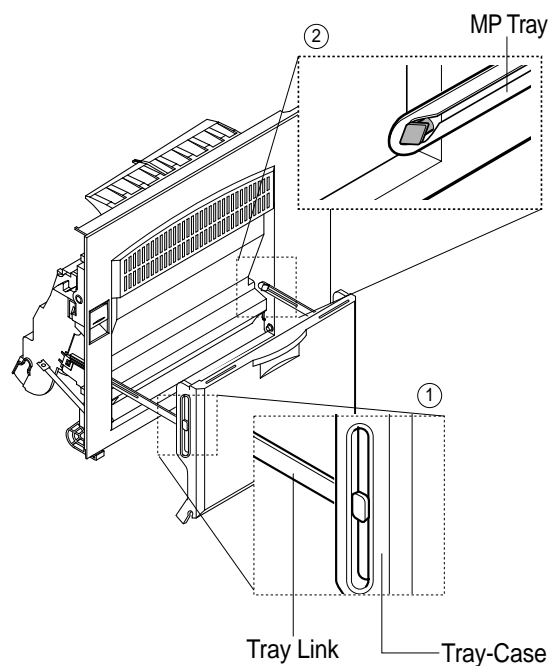

---

### \* Duplex Ass'y

---

1. Unite the ① part and home to the projection part of the Side Cover assembly, and widen them from each other to disassemble the Side Cover Ass'y.

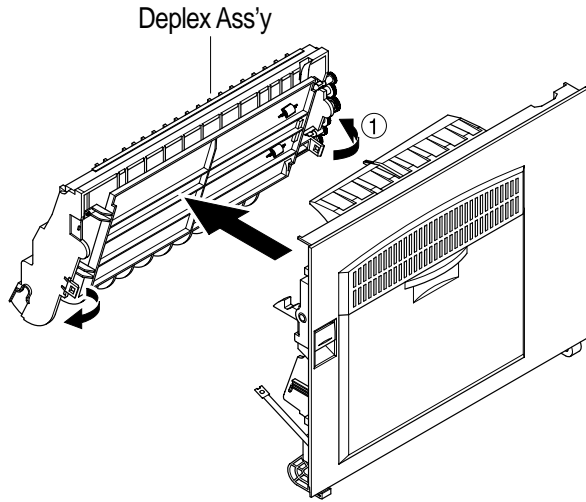

---

### \* Transfer Roller Ass'y

---

1. Take out the Transfer Roller, as shown below.

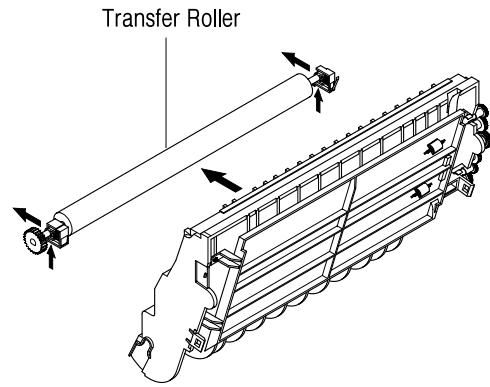

### 3-10 Fuser Ass'y

1. Before you remove the Fuser Ass'y, you should be power off and remove:
  - Side Cover Ass'y (see page 3-9)

2. Remove the one screw and take out the Cover Sheet Connector.

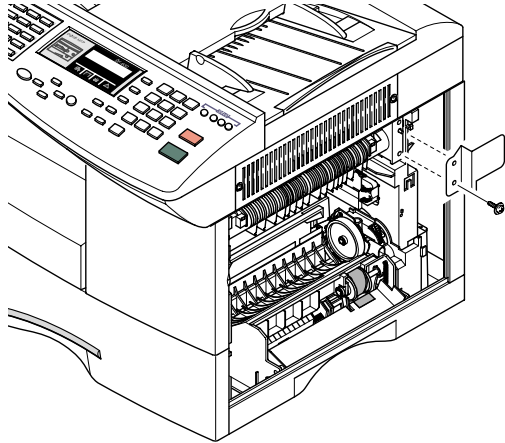

3. Unplug the one connector.

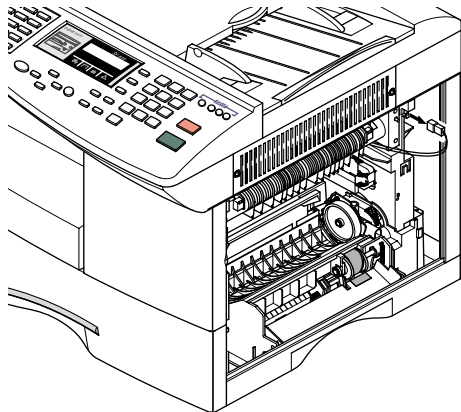

4. Remove the three screws and take out the Fuser Ass'y.

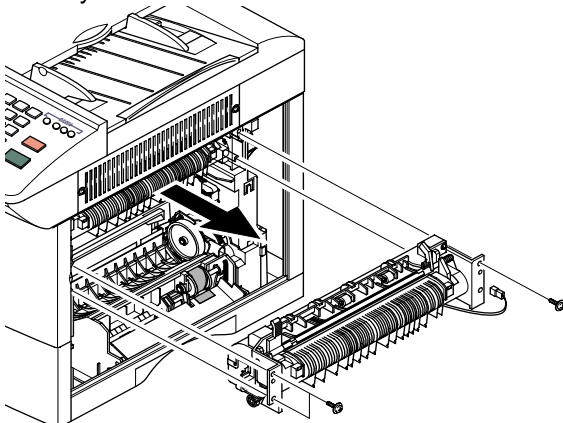

6. Remove the two screws and take out the Halogen Lamp.

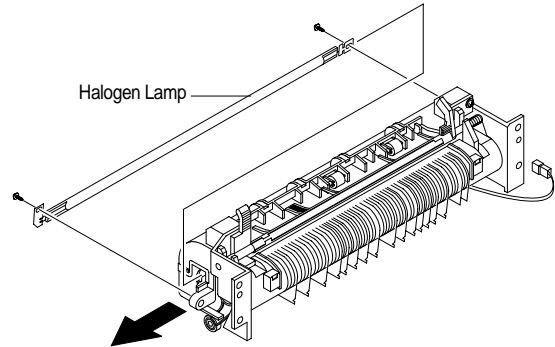

5. Remove the four screws and take out the Thermostat.

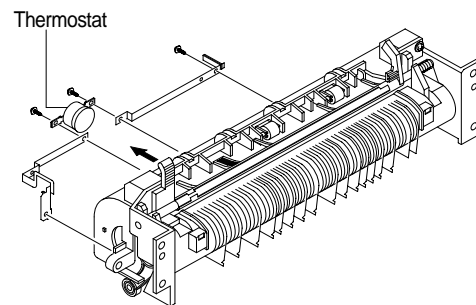

7. After remove the two screw and open the Lower Ass'y forward tack out the Heat Roller Ass'y from Upper Fuser Ass'y.

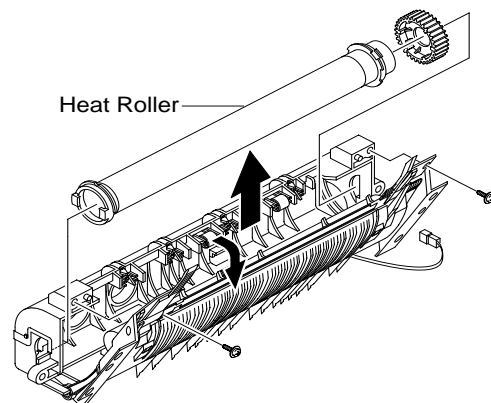

## 3-11 Exit Ass'y

---

1. Before you remove Exit Ass'y, you should remove:

- Rear Cover (see page 3-2)
- Cover Rear Ass'y (see page 3-2)
- Scanner Ass'y (see page 3-3)
- Side Cover Ass'y (see page 3-9)

2. Remove three screws, unplug four connectors and unlatch the Dummy Base Frame, as shown below.

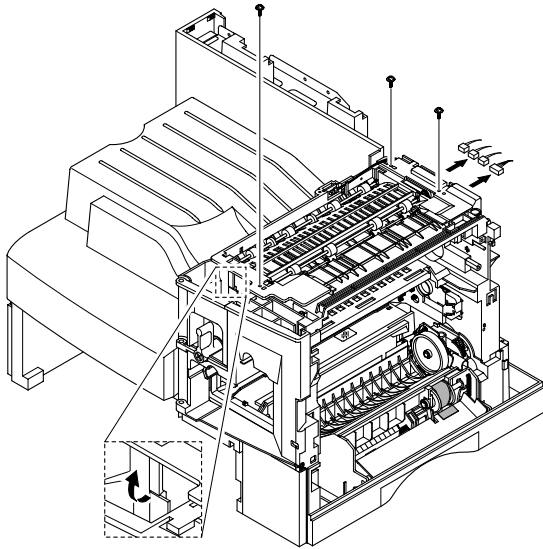

3. Pull the Exit Ass'y and remove it.

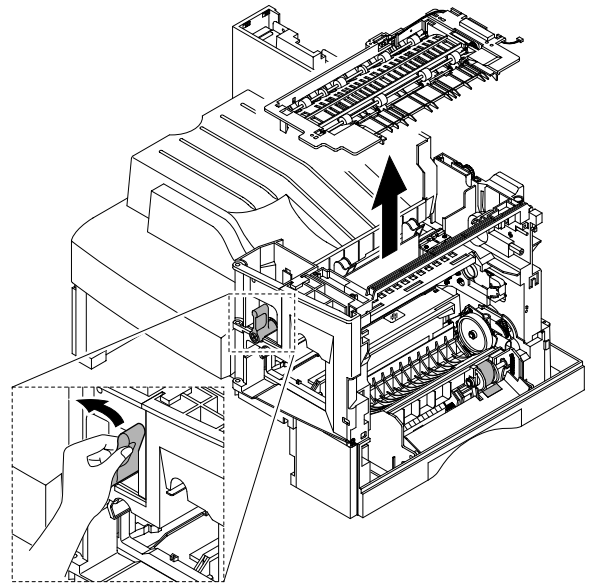

## 3-12 Cover Paper Exit Ass'y

---

1. Before you remove the Cover Paper Exit Ass'y, you should remove:
  - Rear Cover (see page 3-2)
  - Cover Rear Ass'y (see page3-2)
  - Scanner Ass'y (see page3-3)

2. Remove two screws and Cover Paper Exit Ass'y, as shown below.

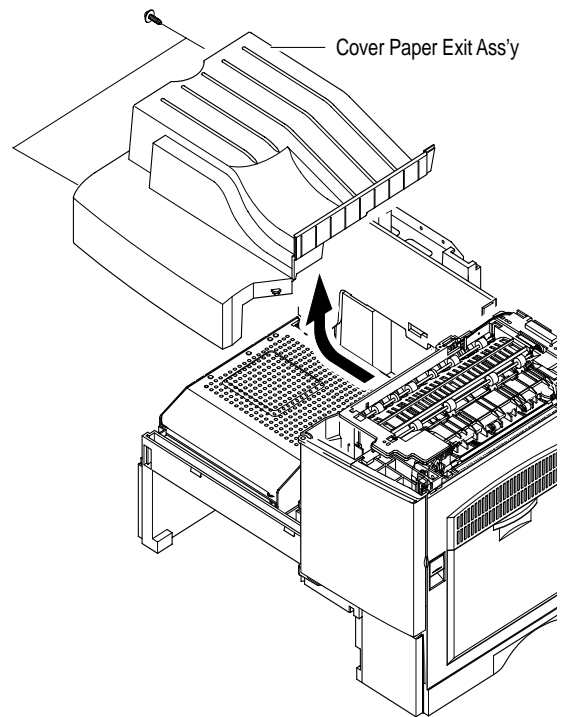

### 3-13 Drive Ass'y

1. Before you remove the Drive Ass'y, you should remove:
  - Rear Cover (see page 3-2)
  - Shield Main Upper (see page 3-2)

2. Unplug the two connectors.  
(Main Motor:9pin, Duplex Solenoid : 2pin)

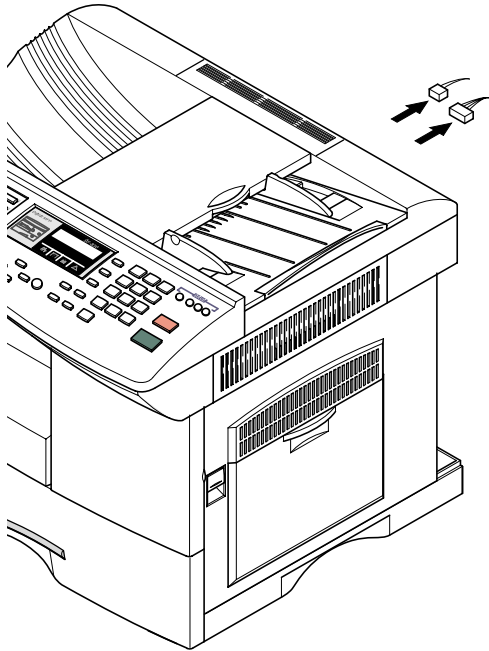

3. Remove the one screw and take out the Fan and Dust Fan.

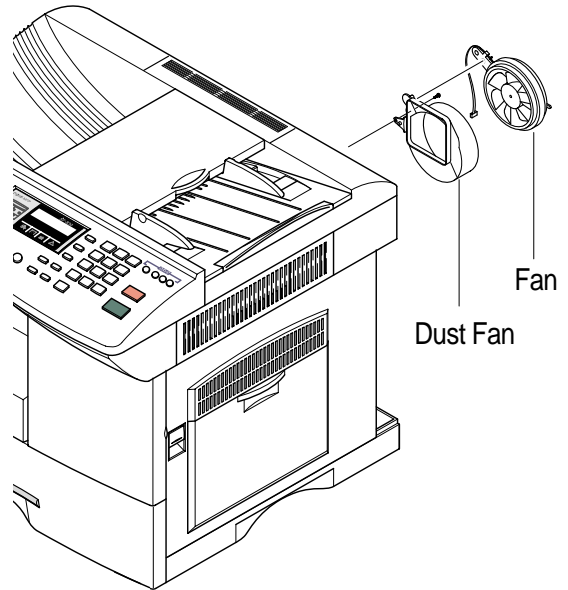

4. Remove the five screws and take out the Drive Ass'y.

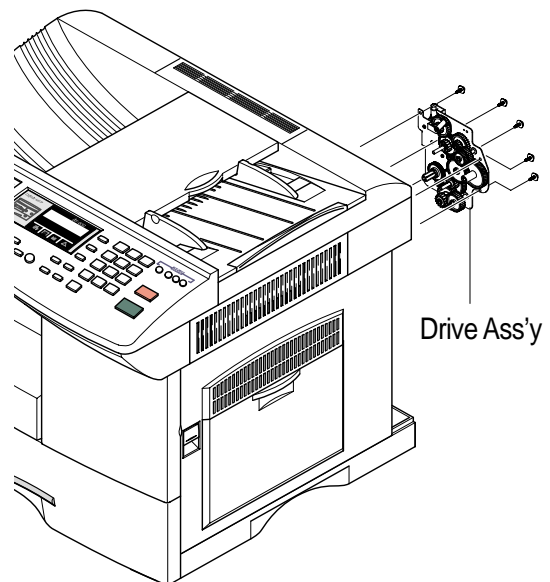

## 3-14 SMPS

1. Before you remove the LSU, you should remove:

- Rear Cover (see page 3-2)
- Cover Rear Ass'y (see page 3-2)
- Scanner Ass'y (see page 3-3)
- Side Cover Ass'y (see page 3-9)
- Exit Ass'y (see page 3-12)
- Cover Paper Exit Ass'y (see page 3-13)

2. Remove three screws and take out the Shield SMPS Upper.

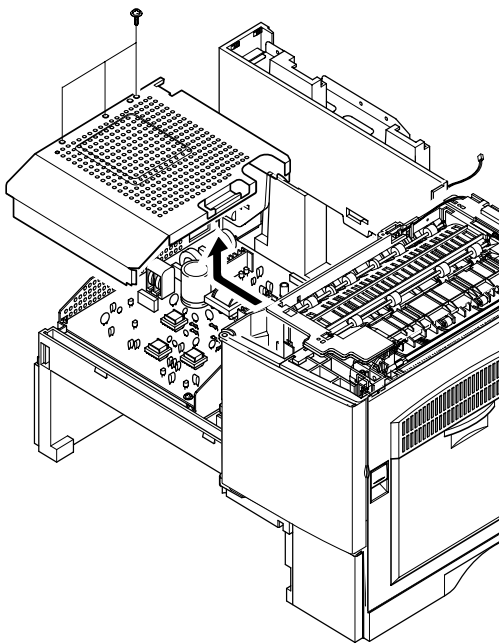

3. Unplug the all connectors.

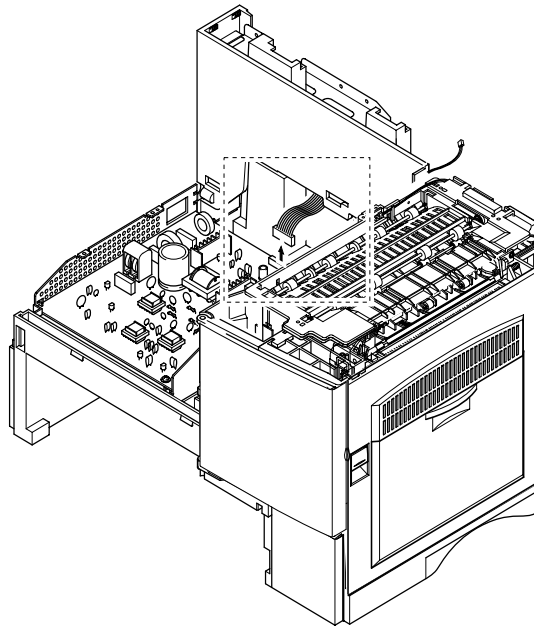

4. Remove the SMPS, as shown below.

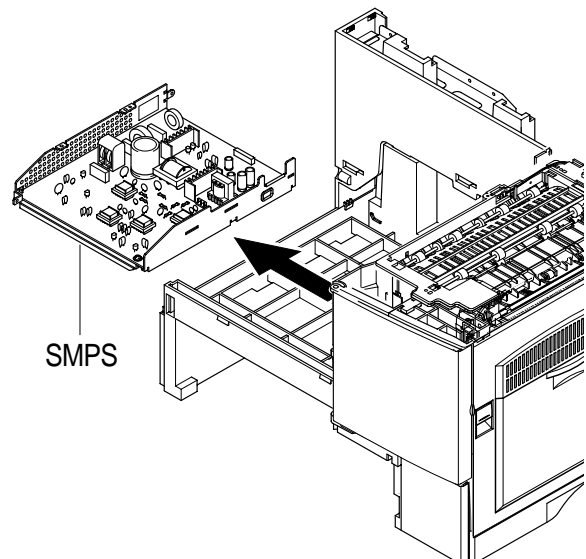

## 3-15 LSU

---

1. Before you remove the LSU, you should remove:

- Rear Cover (see page 3-2)
- Cover Rear Ass'y (see page 3-2)
- Scanner Ass'y (see page 3-3)
- Side Cover Ass'y (see page 3-9)
- Exit Ass'y (see page 3-12)

2. Unplug the two connectors.

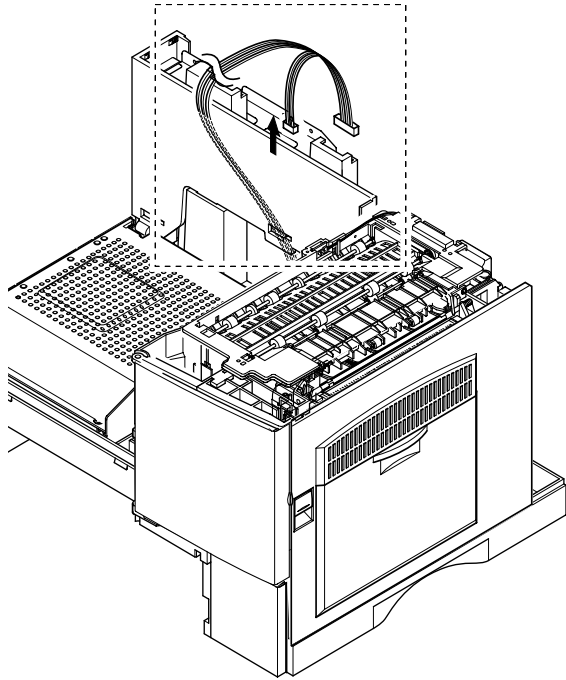

3. Remove the three screws and take out the LSU.

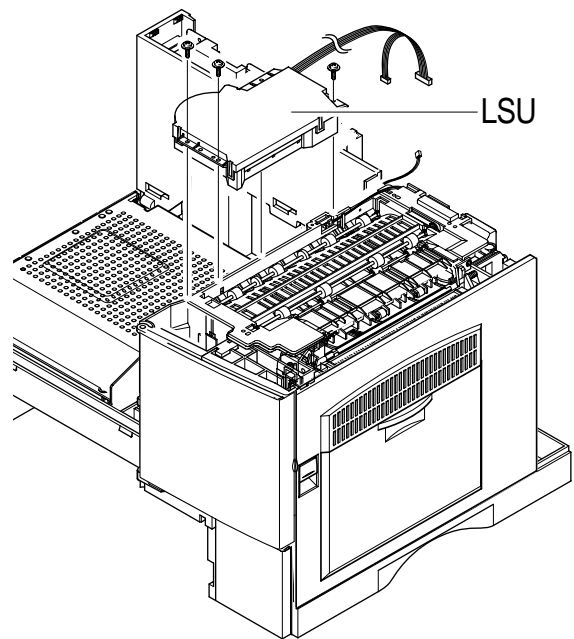

## 3-16 Main Frame Ass'y

1. Before you remove the LSU, you should remove:

- Rear Cover (see page 3-2)
- Cover Rear Ass'y (see page 3-2)
- Scanner Ass'y (see page 3-3)
- Side Cover Ass'y (see page 3-9)
- Exit Ass'y (see page 3-12)
- Cover Paper Exit Ass'y(see page 3-13)
- SMPS (see page 3-15)
- LSU (see page 3-16)

2. Remove one screw in the Channel Base Frame from the bellow section of the Cover Dummy Lower, and then remove the rest of the five screws to disassemble the Dummy Scan Lower.

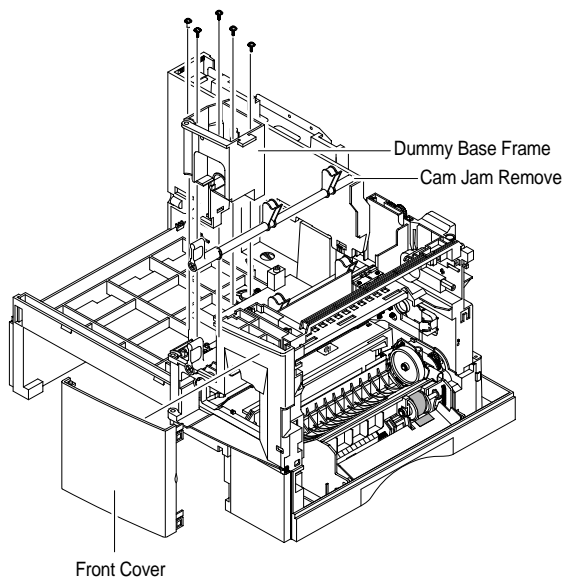

3. Remove the Locker Deve.

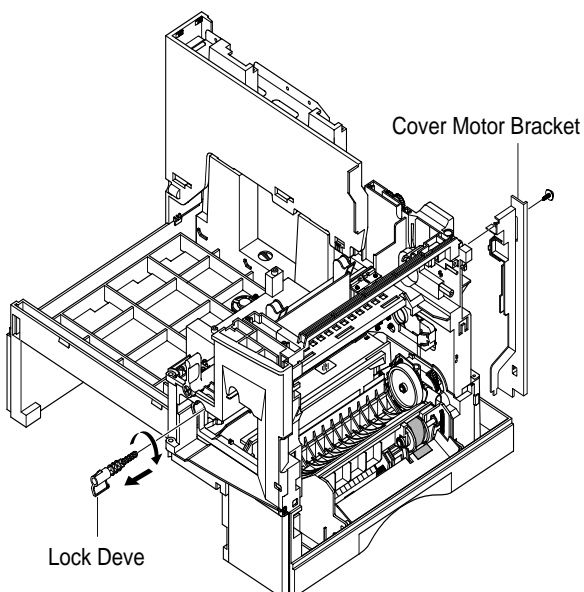

4. Unplug the all connectors.

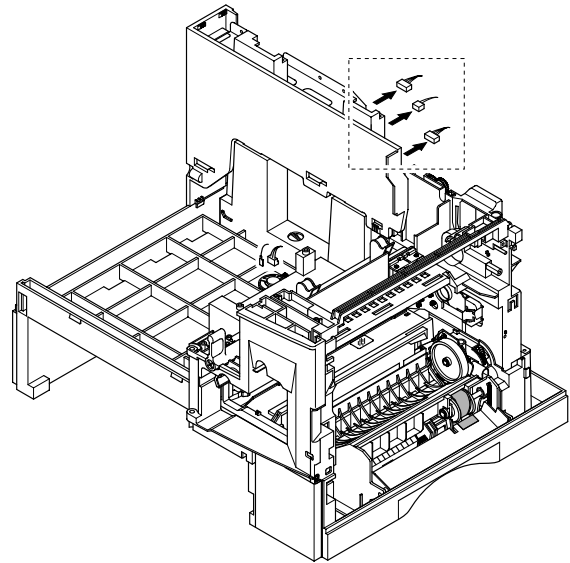

5. Remove the seven screws and take out the Main Frame Ass'y.

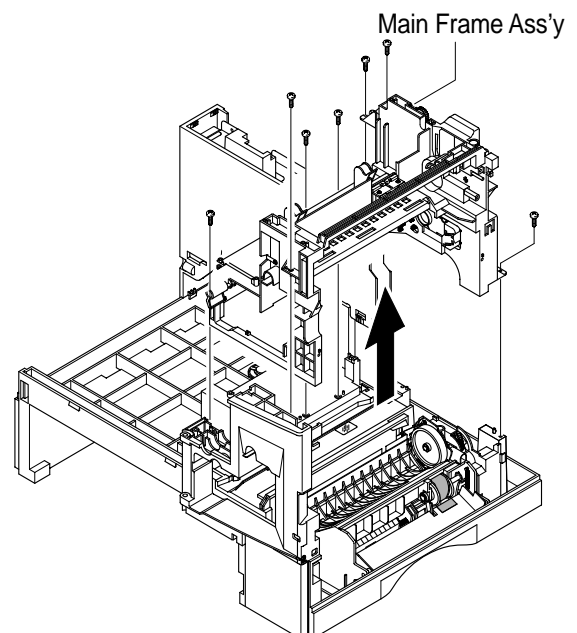

## \* Cover Exit Rear

---

1. Remove the one screw and take out the Panel Connect MPF.

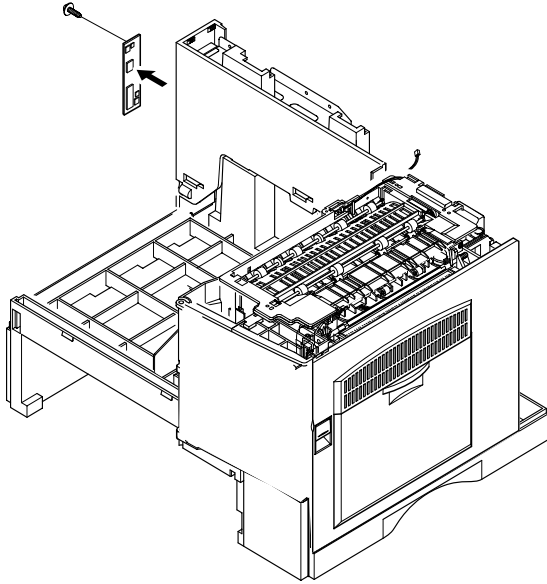

2. Remove the one screw and Cover Exit Rear, as shown below.

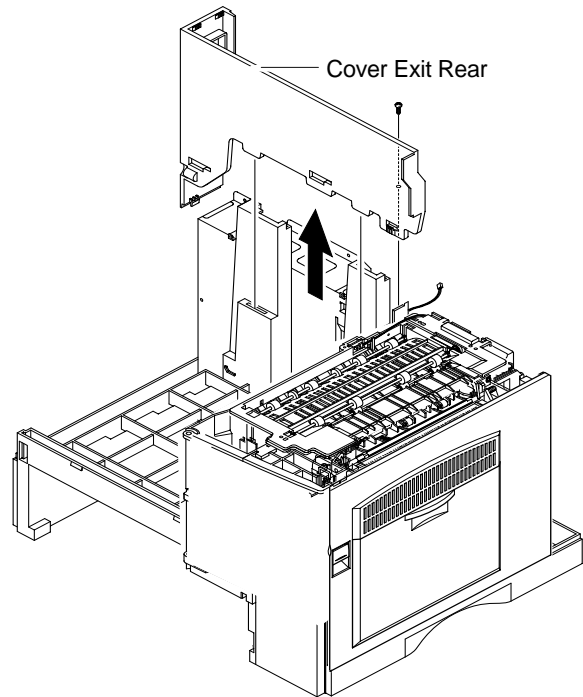

## \* MP Ass'y

1. Unplug the two connectors.

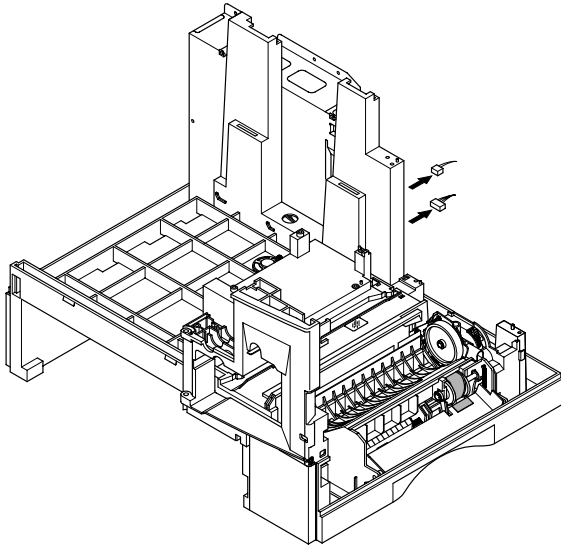

3. Release the SMPS fit. Pull the MP Ass'y Upward and remove it.

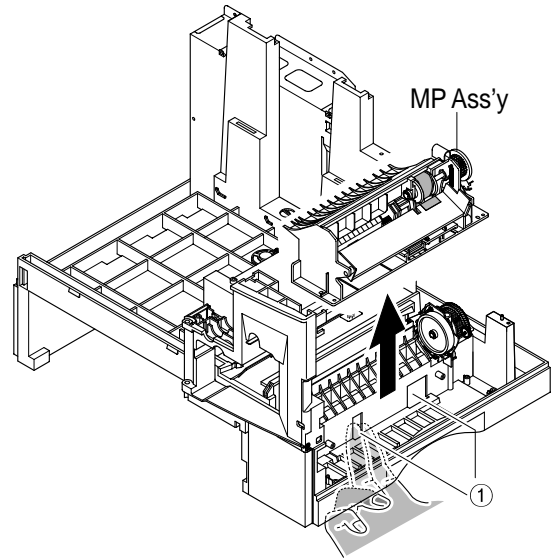

2. Remove the four screws and take out the Dummy Cover.

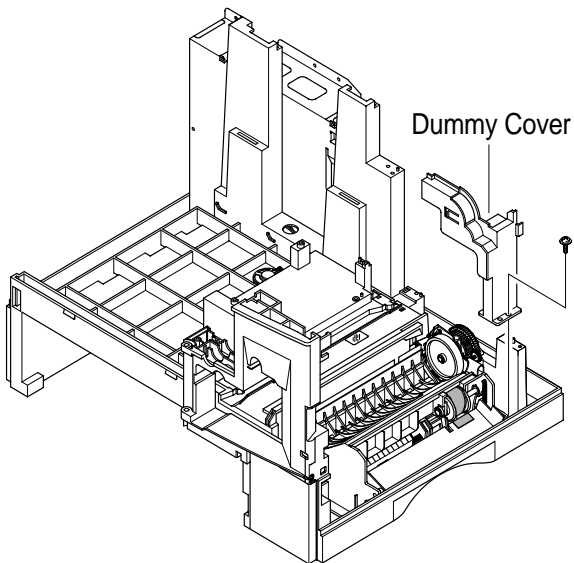

## \* Feed Ass'y

1. Remove the three screws.

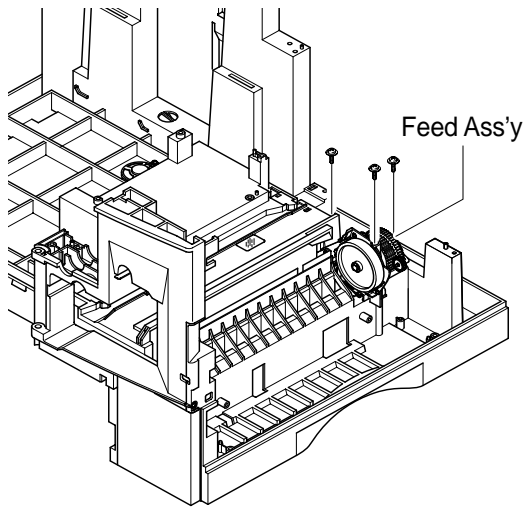

2. Pull the Feed Ass'y upward and remove it.

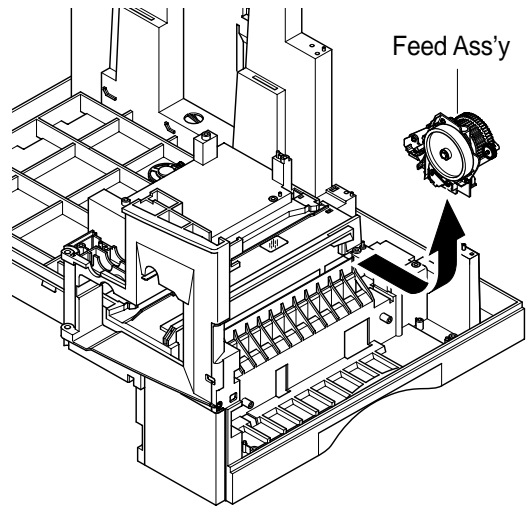

## \* Pick Up Ass'y

1. Unplug the three connectors.

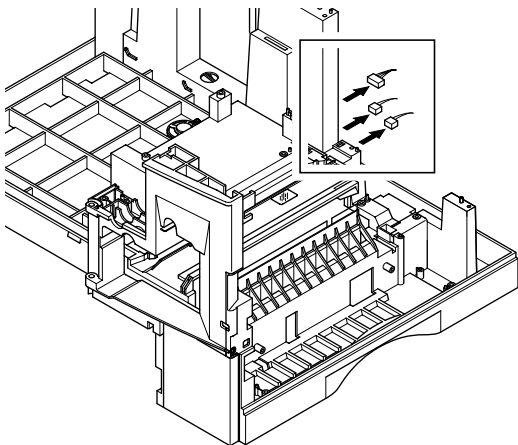

2. Remove the two screws and take out the Cas-  
sette Rail.

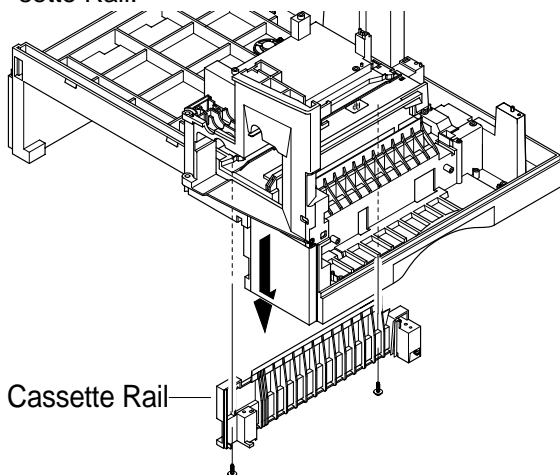

3. Remove the four screws and take out the Pick  
Up Ass'y, as shown below.

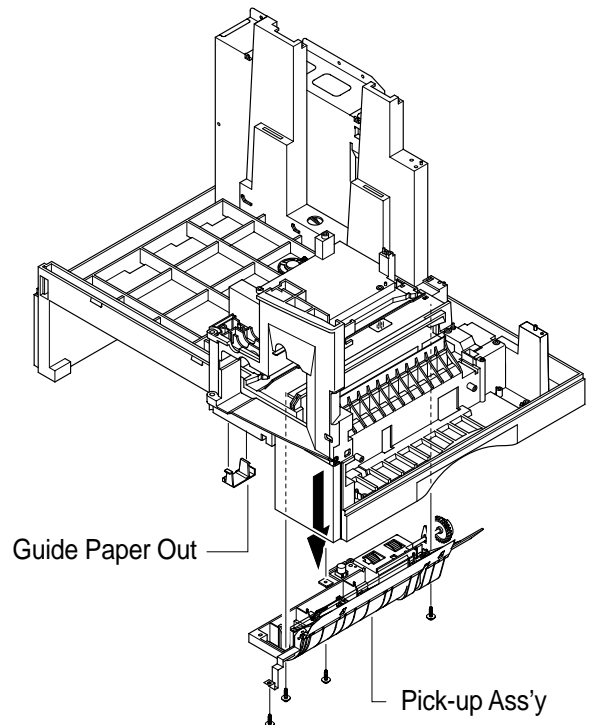

## \* Main PBA

1. Remove the two screws and take out the Shield Main Lower.

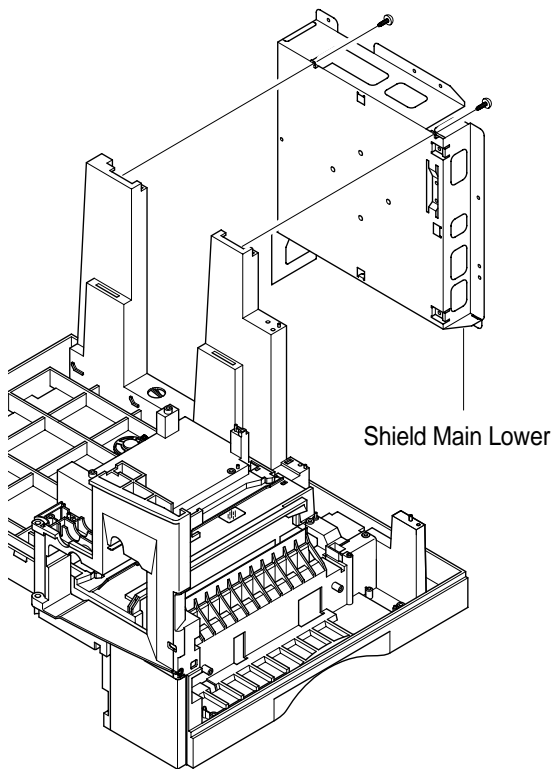

2. Remove the five screws and take out the Main PBA from the Shield Main Lower.

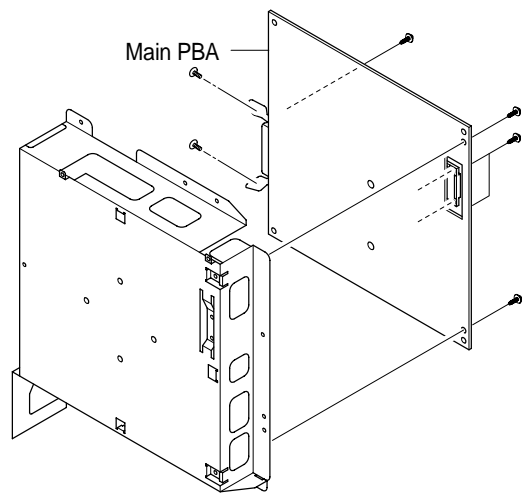

3. Remove the one screw and unlatch the LIU PBA securing the Main PBA and remove it.

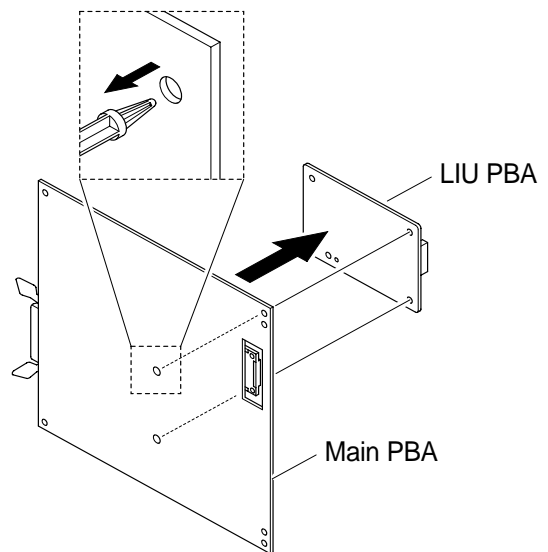

### 3-17 SCF Ass'y

1. Lift the Main Set from the SCF.

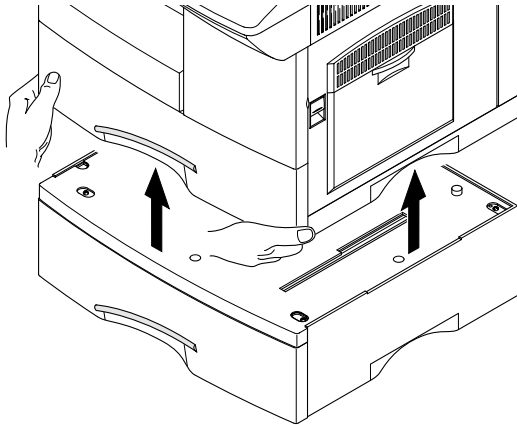

2. Take out the Cassette Ass'y from the SCF.

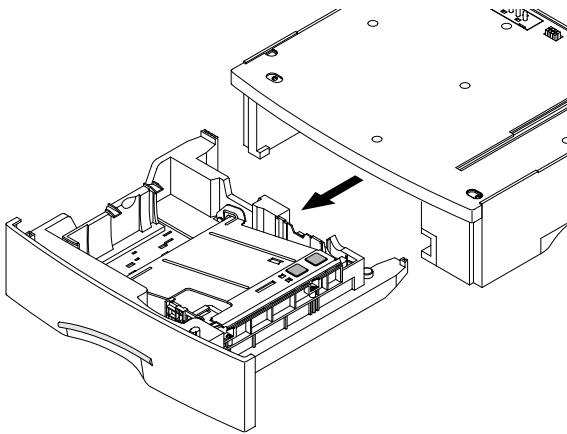

3. Remove the nine screws securing the Top Cover and remove it.

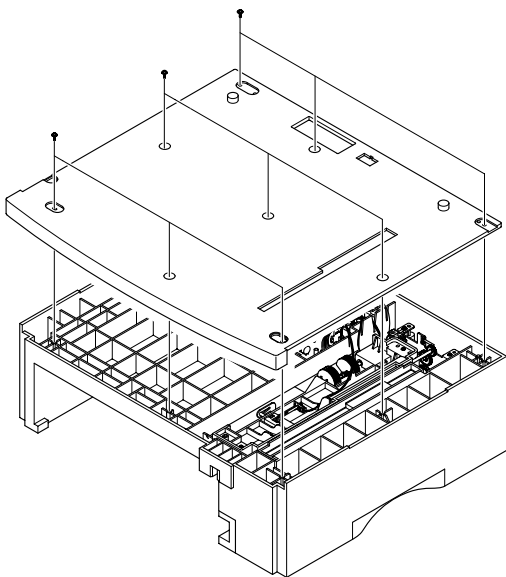

4. Remove the two screws securing the Guide Paper Lower and remove it, as shown below.

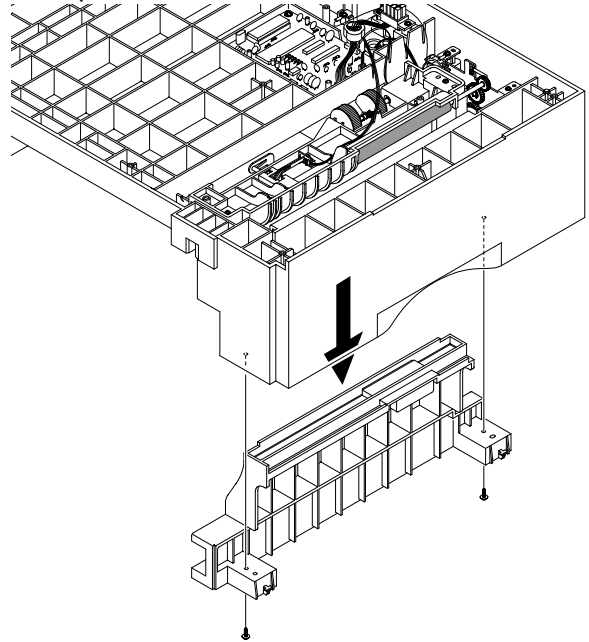

5. Unplug the one connector from the Main PBA, as shown below.

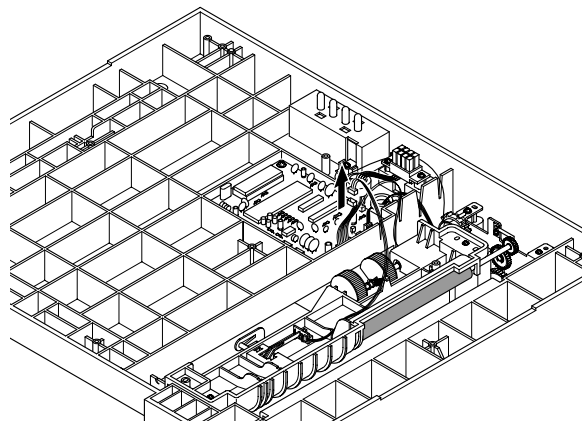

6. Remove the two screws securing the Guide Paper Upper and remove it.

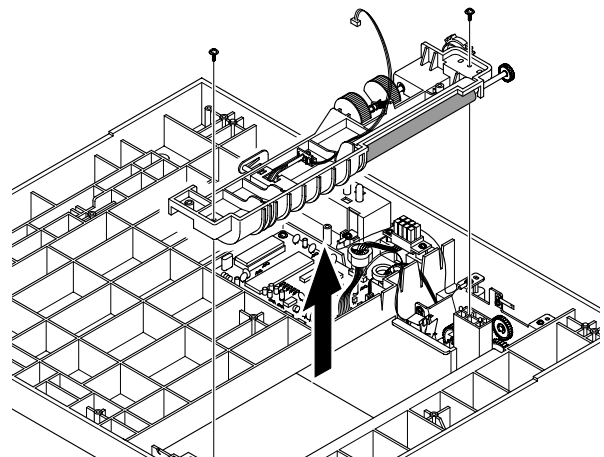

7. Remove the one screw securing the Ground Cable from the Motor Ass'y and remove the Ground Cable.

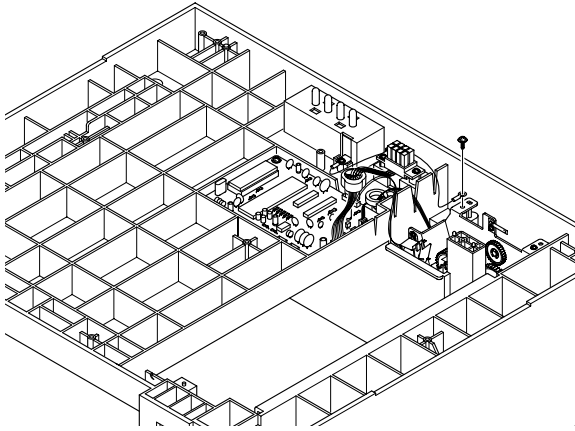

10. Unplug the one connector from the Main PBA, as shown below.

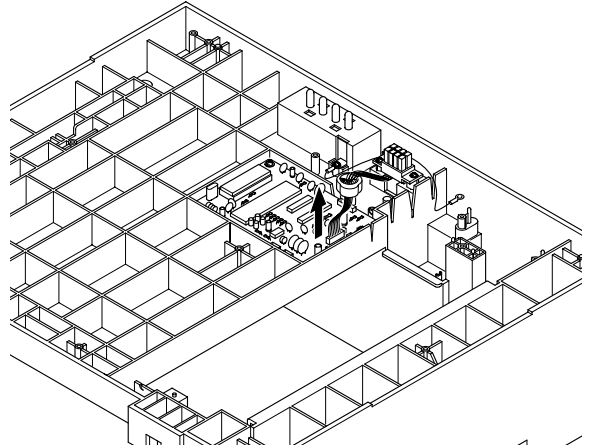

8. Unplug the two connectors from the Main PBA, as shown below.

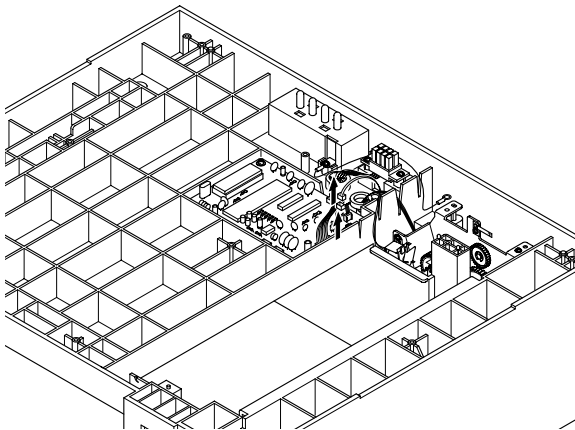

11. Remove two screws securing the SCF 8P Harness and remove it.

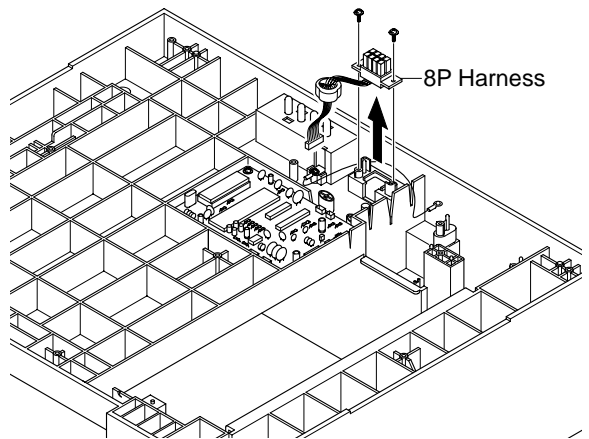

9. Remove the two screws securing the Motor Ass'y and remove it.

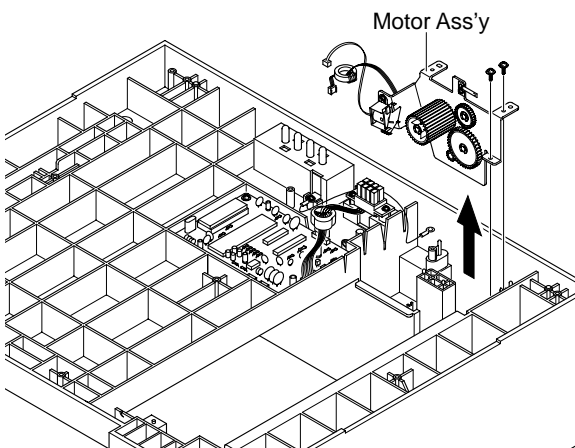

12. Remove the one screw securing the Ground Cable. Remove the Ground Cable from the Plate Ground.

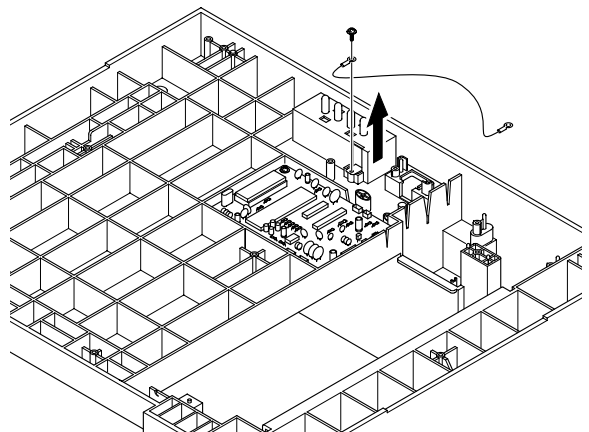

13. Remove the two screws securing the Plate Ground and remove it, as shown below.

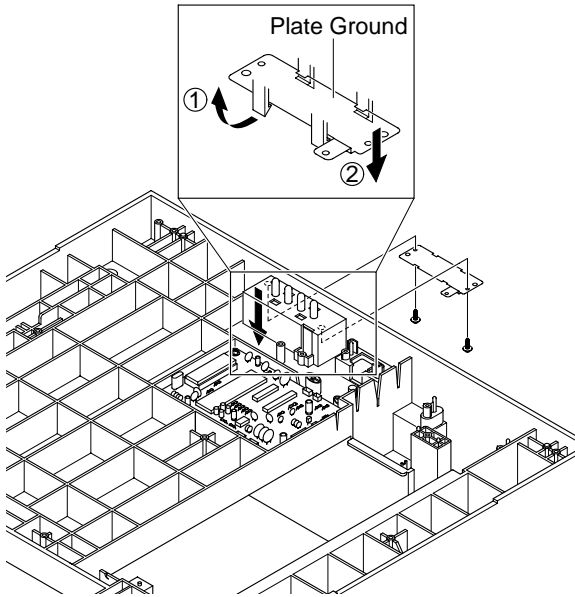

14. Remove the four HV Shaft and HV Spring, as shown below.

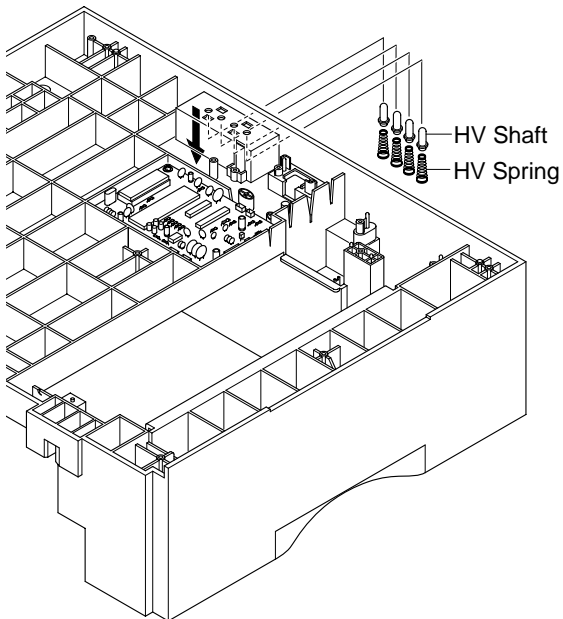

15. Remove the four screws securing the Main PBA and remove it.

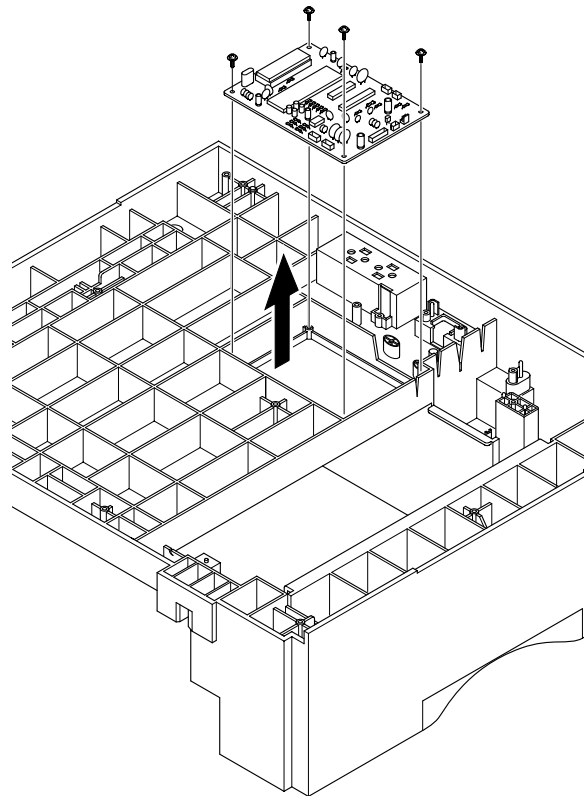

## 4. Maintenance & Troubleshooting

---

In this chapter, it was mentioned about the functions for maintaining the product, how to find the causes of the inferiority, and troubleshooting method.

The service manual is bound the SF-835P and SF-830 together in one volume.

The SF-835P has functions such as printer, copy, scanner, and fax.

The SF-830 has functions such as copy and fax.

The contents of the manual are standardized for the SF-835P.

The information about the fax function is not applied for the SF-830.

The differences by each model are explained in a separate way.

### 4-1 Preventative Maintenance

---

The cycle period outlined below is a general guideline for maintenance.

The example list is for an average usage of 50 transmitted and received documents per day.

Environmental conditions and actual use will vary these factors.

The cycle period given below is for reference only.

COMPONENT	REPLACEMENT CYCLE
ADF Rubber	20,000 Pages
ADF Roller	50,000 Pages
Pick-up Roller	75,000 Pages
Transfer Roller	75,000 Pages
Fuser	75,000 Pages
Toner Cartridge	6,000 Pages
Drum Cartridge	15,000 Pages

## 4-2 Error Messages

Error Message	Description	Solution
RETRY REDIAL?	The machine is waiting for the programmed interval to automatically redial.	You can press START to immediately redial, or STOP to cancel the redial operation.
COMM. ERROR	A problem with the facsimile communications has occurred.	Try again.
DOCUMENT JAM	Loaded document has Jammed in the feeder When Document Jam occurred at ADF module	Clear the document Jam.
DOOR OPEN	The side cover is not securely latched.	Clear the cover until it clicks in place.
GROUP NOT AVAILABLE	You have tried to select a group location where only a single location number can be used, such as when adding locations for a multi-dial operation.	Try again, check location for group.
LINE ERROR	Your unit cannot connect with the remote machine, or has lost contact because of a problem on the phone line. When the machine has a problem in cause of fax data reception step	Try again. If failure persists, wait an hour or so for the line to clear then try again.
LOAD DOCUMENT	You have attempted to set up a sending operation with no document loaded.	Load a document and try again.
MEMORY FULL	The memory has become full.	Either delete unnecessary documents, or retransmit after more memory becomes available, or split the transmission into more than one operation.
NO ANSWER	The remote machine was not answered after all the redial attempts.	Try again. Make sure the remote machine is OK.
NO. NOT ASSIGNED	The speed dial location you tried to use has no number assigned to it.	Dial the number manually with the keypad, or assign the number.
NO PAPER [ADD PAPER]	The recording paper has run out. The printer system stops.	Load the recording paper in the paper feeder.
OVERHEAT	The printer part has overheated.	Your unit will automatically return to the standby mode when it cools down to normal operating temperature. If failure persists, call service.
PAPER JAM 0 OPEN/CLOSE DOOR	Recording paper has jammed in paper feeding area. Recording paper is jammed in pick-up unit	Press STOP and clear the jam.
PAPER JAM 1/2 OPEN/CLOSE DOOR	Recording paper has jammed inside the unit. Recording paper has jammed in paper exit unit.	Clear the jam.
TONER LOW	Toner may be low	Toner may be unevenly distributed. Remove the toner cartridge and shake it gently to evenly distribute the toner. Then replace the toner cartridge.
TONER EMPTY	When the machine has encountered the Toner Empty.	Replace the Toner Cartridge.
DRUM WARNING	When the machine has encountered the drum life, 14000 print pages.	Use little more change if "REPLACE DRUM" is marked in LCD window.
REPLACE DRUM	When the machine has encountered the out of from life, 15000 print pages.	Replace the Drum Cartridge.
NO CARTRIDGE	When the machine detected the toner cartridge has not been installed.	Install the Cartridge.
BYPASS JAM	When the machine detected the non-feeding from BYPASS Tray.	Open the side Cover and clear the jam.

Error Message	Description	Solution
DUPLEX JAM	When the machine detected the duplex jam in the middle of machine.	Clear the jam.
LINE BUSY	The remote FAX didn't answer	Try again.
OPEN HEAT EROR	Thermister does not connected to main board or contact point is not coupled tightly in power on.	Check thermister contact point, Heating Camp & Thermostat.
Heating Error	During operation, Temperature does not go up.	Check thermister contact point & Heating Lamp.

## 4-3 User Mode

The table in the bellow explains the possible setting functions by user.  
 The details about the ways to use are explained in the user manual.  
 In the service manual, the items are about the possible set-up by user.

Function	Item	Content
SYSTEM DATA (Menu + One-touch01)	TRAY PAPER	LETTER / A4 / LEGAL
	BYPASS PAPER	LETTER / A4 / LEGAL
	MESSAGE CONF.	ON / OFF / ERROR
	AUTO JOURNAL	ON / OFF
	RECEIVE CODE	0-9
	POWER SAVE	ON / OFF
	ECN MODE	ON / OFF
	RX REDUCTION	ON / OFF
	DISCARD SIZE	0-30mm
	REDIAL INTERVAL	1-15
	REDIALS	1-13
	ANSWER ON RING	1-7
	SEND FROM MEMORY	ON / OFF
	LOCAL ID	ON / OFF
CLOCK MODE	12 / 24 HOUR	
SYSTEM ID (Menu + One-touch02)	FAX / ID	
DATE & TIME (Menu + One-touch03)		
SYSTEM SETUP (Menu + One-touch04)	RECEIVE MODE	FAX :
	PREFIX DIAL NO.	FAX , ANS/FAX , TEL
	RINGER VOLUME	LOW / HIGH (10 STEPS)
	ALARM SOUND	ON / OFF
	KEY SOUND	ON / OFF
	SPEAKER CONTROL	COM / ON /OFF
	SELECT LANGUAGE	ENG/GER/FRE/ITA/SPA/POR/DUT
	FAX DUPLEX	OFF / LONG EDGE / SHORT EDGE
	PAPER TYPE	PLAIN PAPER/BOND/TRANSPAR- ENCY/CARD STOCK/LABELS/PRE- PRINTED/COLORED/ENVELOPE
MEMORY CLEAR (Menu + One-touch05)	SYSTEM ID	
	SYSTEM DATA	
	PHONE BOOK/MEMORY	
	TX-RX JOURNAL	
DELAY TX (Menu + One-touch06)		
MEMORY TX (Menu + One-touch07)		
PRIORITY TX (Menu + One-touch08)		
POLLING (Menu + One-touch09)		
ADD/CANCEL (Menu + One-touch10)	ADD / CANCEL	
GROUP DIAL (Menu + One-touch11)		
MAINTENANCE (Menu + One-touch12)	ADJUST SHADING	
	CLEAN DRUM	
	NEW DRUM	ON / OFF
	NOTIFY TONER	
MAIL BOX (Menu + One-touch13)	1: SET , 2: PRINT	
CONFIDENTIAL TX (Menu + One-touch14)		
DEPARTMENT CODE (Menu + One-touch15)		
TX CONFIRM (Menu + One-touch16)		
SCHEDULE JOB (Menu + One-touch17)		
PHONE BOOK (Menu + One-touch18)		
SYSTEM LIST (Menu + One-touch19)		
TX JOURNAL (Menu + One-touch20)		
RX JOURNAL (Menu + One-touch21)		
HELP LIST (Menu + One-touch22)		HELP LIST

## 4-4 Tech Mode

---

### 4-4-1 How to Enter Service Mode

In service mode (tech) mode, the technician can check the machine and perform various test to isolate the cause of a malfunction.

To enter the Tech mode, press **MENU, #, 1, 9, 3, 4** in sequence, and the LCD briefly displays 'T', the machine has entered service (tech) mode.

While in Tech mode, the machine still performs all normal operations.

To return to normal user mode, press **MENU, #, 1, 9, 3, 4** in sequence again, or turn the power off, then on by unplugging and plugging the power cord.

Options changed while in service mode do not remain changed unless you clear the machine's memory.

## 4-4-2 Setting-up System in Tech Mode (SETUP : #, 1, 9, 3, 4)

Title (Key)	Items	Sub-itmes	
SYSTEM DATA(Menu + One-touch01) TECH MODE/USER MODE	DIAL MODE	TONE / PULSE	
	MODEM SPEED		
	ERROR RATE	5% /10%	
	SET TX LEVEL	09-15	
	SILENCE TIME	12 / NU / OFF	
	BATCH TX	ON / OFF	
SYSTEM ID(Menu + One-touch02)	The same as User Mode.		
DATE & TIME (Menu + One-touch03)	The same as User Mode.		
SYSTEM SETUP (Menu + One-touch04)	The same as User Mode.		
MEMORY CLEAR (Menu + One-touch05)	CLEAR ALL MEMORY		
DELAY TX (Menu + One-touch06)	The same as User Mode.		
MEMORY TX (Menu + One-touch07)	The same as User Mode.		
PRIORITY TX (Menu + One-touch08)	The same as User Mode.		
POLLING (Menu + One-touch09)	The same as User Mode.		
ADD/CANCEL (Menu + One-touch10)	The same as User Mode.		
GROUP DIAL (Menu + One-touch11)	The same as User Mode.		
MAINTENANCE (Menu + One-touch12)	ADJUST SHADING		
	CLEAN DRUM		
	NEW DRUM		
	NOTIFY TONER	ON / OFF	
	SWITCH TEST		
	MODEM TEST		
	SRAM TEST		
	DRAM TEST		
	ROM TEST	FLASH / ENGINE	
	PATTERN TEST	"1-7 , ALL"	
	CLEAR COUNT	PASSWORD (1, 9, 3, 4)	
		TOTAL PAGE COUNT	
		CRU PRINTS COUNT	
		ADF SCAN COUNT	
		USED DRUM COUNT	
		USED TONER COUNT	
ANSWER ON CNG	1-4		
FLASH UPGRADE	LOCAL		
	REMOTE :		
	USER PROGRAM , EMULATION ,BOOT PRO-GRAM		
PROGRAM DIAL	1 : SET , 2 : PRINT		
MAIL BOX (Menu + One-touch13)	1 : SET , 2 : PRINT		
CONFIDENTIAL TX (Menu + One-touch14)			
DEPARTMENT CODE (Menu + One-touch15)	CODE = *****		
TX CONFIRM (Menu + One-touch16)	The same as User Mode.		
SCHEDULE JOB (Menu + One-touch17)	The same as User Mode.		
PHONE BOOK (Menu + One-touch18)	The same as User Mode.		
SYSTEM LIST (Menu + One-touch19)	USER MODE		
TX JOURNAL (Menu + One-touch20)	The same as User Mode.		
RX JOURNAL (Menu + One-touch21)	The same as User Mode.		
HELP LIST (Menu + One-touch22)	MSG. CONFIRM		
	SCHEDULE JOB		
	PHONE BOOK		
	SYSTEM DATA		
	TRANSMISSION		
	RECEPTION		
	HELP LIST		
	PROTOCOL		
ERROR CODE			

## 4-4-3 SYSTEM DATA

### DIALING MODE

---

Select the dialing mode according to the user's line status.

- TONE: Electrical type of dial
- PULSE: Mechanical type of dial

### SILENCE TIME

---

In ANS/FAX mode, after a call is picked up by the answering machine, the machine monitors the line. If a period of silence is detected on the line at any time, the call will be treated as a fax message and the machine begins receiving.

Silence detection time is selectable between limited (about 12 seconds) and unlimited time.

When '12 sec' is selected, the machine switches to receiving mode as soon as it detects a period of silence.

When 'unlimited' is selected, the machine waits until the answering operation is concluded even though a period of silence is detected. After the answering operation is concluded, the machine switches to receiving mode.

### SET FAX LEVEL

---

You can set the level of the transmission signal. Typically, the Tx level should be under -12 dBm.

Caution: The Send Fax Level is set at the best condition in the shipment from factory. Never change settings arbitrarily.

### ERROR RATE

---

When the error rate is about to be over the setting value, the Baud rate automatically lowers up to 2400 bps to make the error rate remain below the setting value.

You can select the rate between 5% and 10%.

### MODEM SPEED

---

You can set the maximum modem speed.

Communication is done with modem speed automatically set at lower speed when communicating with the modem with lower speed since communication is done on the standard of the side where modem speed is low for transmission/reception. It is better set 33.6Kbps as default setting.

## 4-4-4 MEMORY CLEAR

### CLEAR ALL MEMORY

---

The function resets the system as its very first condition as setting in at the factory.

This function is needed to operate to reset the system to the initial value when the product is abnormally operated or malfunction. All the values are returned to the default values, and all the information, which set in by user, will be erased.

#### < Method >

1. Select the [MEMORY CLEAR] at the TECH MODE.
2. Push the ENTER button.
3. Select you country.
4. Push the ENTER button then it will be all memory clear . .

NOTICE : Always perform the memory clear after replace the main board. Otherwise, the system may not operate properly.

## 4-4-5 MAINTENANCE

### ADJUST SHADING

The function is to control to get the optimum scan quality by the specific character of the CIS(Contact Image Sensor) If the copy image quality is unsatisfied, perform the function to check the condition of the print out for checking whether or not having CIS trouble.

#### < Method >

1. Select [ADJUST SHADING] from the TECH MODE.
2. Insert a clean white original [Letter Size] into the paper loading part.
3. Original is scanned if pressing the Enter button.
4. If the original scan is completed, message is displayed on the LCD window and CIS SHADING PROFILE is output.
5. If the output image is different from the normal screen, the CIS is poor.

#### Caution:

1. Always perform the CIS TEST after downloading Firmware. Otherwise, the system may not operate properly.
2. Always perform ADJUST SHADING after replacing the CIS.
3. Always use a clean white paper in ADJUST SHADING (Maximum paper width: Letter Size).  
ADJUST SHADING may be performed even in the User Mode but ADJUST SHADING profile is output only in the TECH MODE.

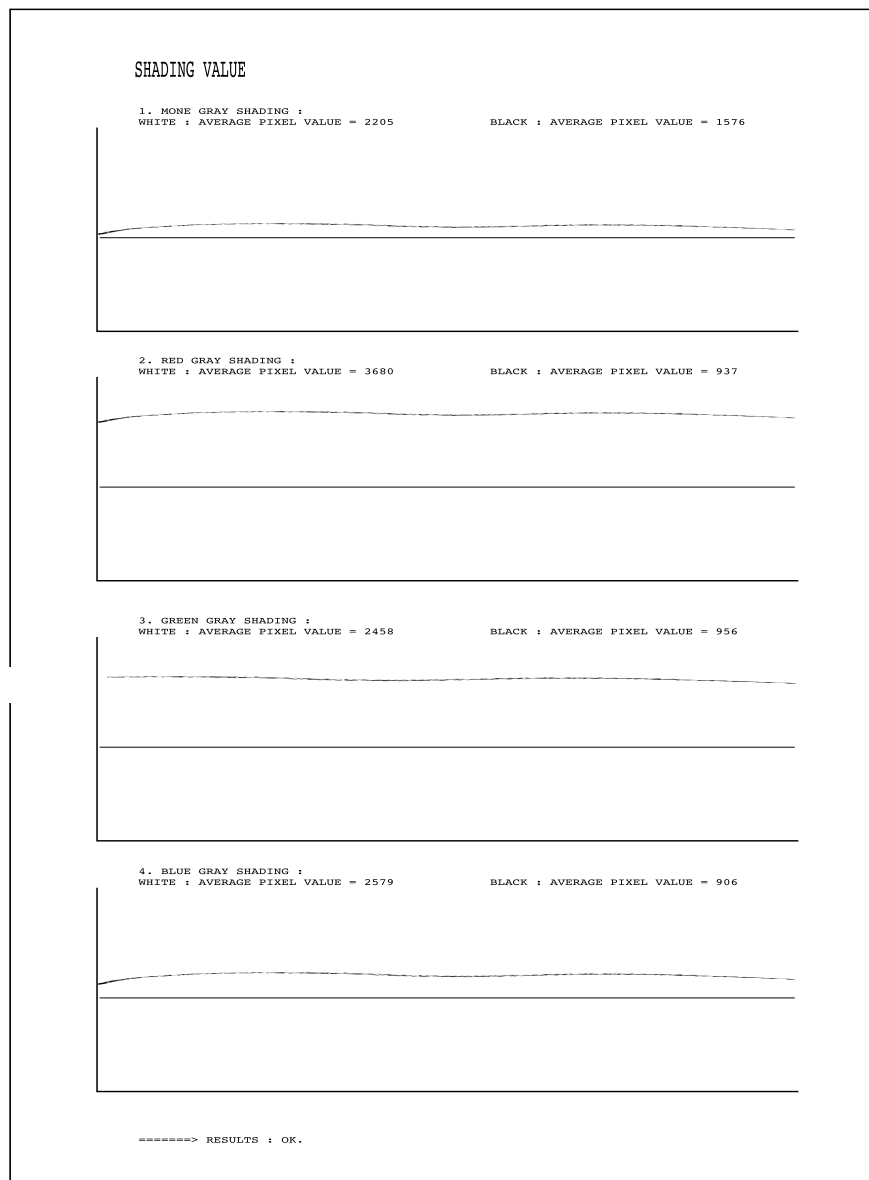

< ADJUST SHADING >

## CLEAN DRUM

---

Use this feature to get rid of the toner remained in the development unit, so you can get a clean printout. Perform this feature if stains or specks appear on the printing materials and print quality falls. Perform this feature several times until a clean printing material appears.

The machine automatically pulls in a sheet of paper, and prints out. The toner particles on the OPC drum surface is fixed to the paper.

## FLASH UPGRADE

---

It is Firmware Upgrade function and has two methods, Local and Remote. More information can be found in the firmware upgrade items.

## ANSWER ON CNG

---

The function is to control the CNG TONE cognition times for entering receiving mode from the AUTO MODE or ANS/FAX MODE

## CLEAR COUNT

---

This function erases information of history such as replacement times of Developing part and OPC drum, total printing pages, scan times, and etc.

- The items are in the below section of the System Data List, printed at TECH MODE.
- PASSWOEEED: 1934
- Current Drum Page Count cannot be erased.

It is possible to erase at NEW DRUM function (USER MODE ⇒ MINTENANCE ⇒ NEW DRUM)

FIRMWARE VERSION	:	1.00
ENGINE VERSION	:	1.00
EMULATION VERSION	:	PCL6 2.32 02-11-2002
		PCL5e 1.48 02-19-2002
TOTAL PAGE COUNTS	:	123
CRU PRINTS	:	123
REPLACED TONER COUNTS	:	1
REPLACED DRUM COUNTS	:	1
CURRENT DRUM COUNTS	:	112
ADF SCAN PAGE COUNTS	:	10

< SYSTEM DATA LIST >

## PATTERN TEST

---

Using this pattern printout, you can check if the printer mechanism is functioning properly. It is needed in the production progress. Service person doesn't need to use it.

## ROM TEST

---

Use this feature to test the machine'S ROM. The result and the software version appear in the LCD display.

- FLASH VER : 1.00 V
- ENGINE VER :1.00V

## **DRAM TEST**

---

Use this feature to test the machine's DRAM. The result appears in the LCD display.  
If all memory is working normally, the LCD shows << O K >>

## **SRAM TEST**

---

Use this feature to test the machine's SRAM. The result appears in the LCD display.  
If all memory is working normally, the LCD shows << O K >>

## **MODEM TEST**

---

Use this feature to hear various transmission signals to the telephone line from the modem and to check the modem. If no transmission signal sound is heard, it means that the modem part of the main board is poor.

## **SWITCH TEST**

---

Use this feature to test all keys on the operation control panel. The result is displayed on the LCD window each time you press a key.

## **NOTIFY TONER LOW**

---

With this feature enabled, when the toner becomes low, the toner low information will be sent to a specified contact point, for example, the service company. After you access this menu, select ON, and when the LCD prompts, enter the name and the number of the contact point, the customer's fax number, the model name, and the serial number.

## **PROGRAM DIAL**

---

It is a function setting transmitting conditions to transmit to specific address preliminary.  
When user transmit specific address set this function, the condition supplied automatically.

## 4-4-6 REPORT/HELP

### MSG. CONFIRM

---

It shows the result of the last send operation.

### PROTOCOL LIST

---

This list shows the sequence of the CCITT group 3 T.30 protocol during the most recent sending or receiving operation. Use this list to check for send and receive errors. If a communication error occurs while the machine is in TECH mode, the protocol list will print automatically.

Sending/Receiving	Name of signal (Facsimile Control Field)	Facsimile Information Field data described in hexadecimal code	FIF data described in ASCII code
S/R	FCF	FIF DATA	ASCII
S	NSF	61005820003380140200001302090018010000	
S	CSI	20202020202020202020202020202020202020	
S	DIS	00000000 01110111 00010111 00100010	
S	NSF	61005020003380140200001302090018010000	
S	CSI	20202020202020202020202020202020202020	
S	DIS	00000000 01110111 00010111 00100010	
R	TSI	20202020202020202020202020202020202020	
R	DCS	00000000 01100001 00010101 00000000	
S	FTT		
R	TSI	20202020202020202020202020202020202020	
R	DCS	00000000 01100001 00010101 00000000	
S	CFR		
R	MPS		
S	MCF		
S	DCN		

< PROTOCOL LIST >

### HELP

---

It shows a brief description on the machine's basic functions and commands. Use it as a quick reference guide

### RECEPTION

---

This journal shows a specific information concerning reception activities, the time and dates of up to 40 of the most recent receptions.

### TRANSMISSION

---

This journal shows a specific information concerning transmission activities, the time and dates of up to 40 of the most recent transmissions.

### SYSTEM DATA

---

This list provides a list of the user system data settings and tech mode settings.

### PHONEBOOK

---

It lists all telephone numbers that have been stored in the machine.

### SCHEDULE JOB

---

This list shows a specific information on the documents currently stored for delayed transmission. It provides the operation number, starting time, type of operation, etc.

### ERROR CODE

---

It shows error history occurred using product.

## 4-4-7 Firmware Upgrade

It is a new Firmware, and there are two Upgrade methods by local and remote.

### 4-4-7-1 Local Machine

#### RCP(Remote Control Panel) mode

---

This method is for Parallel Port.or USB Port Connect to PC and activate RCP(Remote Control Panel) to upgrade the Firmware.

##### < Method >

How to Update Firmware using RCP

1. Connect PC and Printer with Parallel Cable or USB Cable.
2. Execute RCP and select Firmware Update. Current Firmware version and Emulation Version are displayed on Current version window.
3. Search Firmware file to update with Browse Icon.
4. Click Update icon, firmware file is transmitted to Printer automatically and printer is initialized when it finished.
5. Click Refresh icon and check what is updated.

#### DOS Command mode

---

This method is just for Parallel Port. Connect to PC with Parallel cable and enter DOS Command to upgrade the Firmware.

##### < Method >

- a). The first of all, need the files : **down.bat**, **down\_com.bin**, **fprt.exe**, and **Rom File**: file name for upgrade.Save the files in the same folder.
- b). In the DOS, input as below and push the enter key. Then, it will be automatically upgraded.
- c) There are two commands for the conditions of product.
  - \* When the product is in idle condition  
**down "rom file"**
  - \* When the product is in idle condition(TECH MODE → MAINTENANCE → FLASH UPGRADE →LOCAL)  
**fprt "rom file"**
- d) Do not turn off the power while upgrading process.

### 4-4-7-2 Remote FAX

This is a function that a fax with the latest firmware sends files to a fax in long distance through telephone line.

##### < Method >

1. Operate a fax with the latest firmware to prepare it being upgrade.  
(TECH MODE MAINTENANCE FLASH UPGRADE REMOTE)
2. Input the fax number, which needs to be upgraded.  
(Several faxes can be upgrade at the same time. In this case, enter the each fax number.)
3. After push the enter button, send the firmware file by calling to the appointed number.  
(Around 10~15 minutes needs to send the file.)

##### < Caution >

1. sending and receiving fax must be the same model.
2. A sending fax must be set up as ECM mode, and a receiving memory must be set up as 100%.  
If not, the function operates abnormally.

## 4-5 Identify Sale Date

---

This function confirms the date that consumer buys product and use product by first actually. If make consumer buy and operate the machine, the machine recognize the first Scan page count, Print page count etc.  
The time is remembered to first machine use event.

### < Method >

These contents are remembered continuously after memory delete (Clear All Memory).  
Method : Press **MENU, #, 1, 9, 3, #** in sequence. Firmware version is displayed on LCD.

FLASH VER : 1.00 ENGINE VER : 1.00
---------------------------------------

Press 1( in the number keypad) : The LCD display shows "Updated date"  
Press 2( in the number keypad) : The LCD display shows "Product first use date"

## 4-6 ENGINE TEST MODE

The Engine Tests Mode supplies useful functions to check conducting condition of engine. It tests the conducting condition of each device and displays the result of the test at the LCD. It is classified in 6. items (0~5), and the functions of items are as bellows.

### 4-6-1 To enter the Engine Test Mode

Press **MENU, #, 1, 9, 3, 1** in sequence, and the LCD briefly displays 'Engine Test', the machine has entered Engine Test Mode.

### 4-6-2 Diagnostic



No.	Sub No.	Engine test	Remark
0	1	Motor Test	1: On, 2: Off
	2	PTL Test	1: On, 2: Off
	3	Fan Test	1: On, 2: Off
	4	Fuser Test	1: On, 2: Off If its temperature is lower than the Standby (160°C), the fuser is on, but if it is higher than the Standby, the fuser is off.
1	1	LSU Motor Test	1: On, 2: Off
	2	LSU Hsync Test	1: On, 2: Off
	3	LD On Test	1: On, 2: Off
	4	LSU Operation	1: On, 2: Off
2	1	Feed Sensor Test	Sensor On : FEED SENSOR ON Display
			Sensor Off : FEED SENSOR OFF Display
	2	Exit Sensor Test	Sensor On : EXIT SENSOR ON Display
			Sensor Off : EXIT SENSOR OFF Display
	3	Cover Sensor Test	Sensor On : COVER SENSOR ON Display
			Sensor Off : COVER SENSOR OFF Display
4	1'st CAST Empty Test	Sensor On : 1'st PAPER Empty Display	
		Sensor Off : 1'st PAPER No Empty Display	
5	MP Empty Sen Test	Sensor On : MP PAPER Empty Display	
		Sensor Off : MP PAPER No Empty Display	
6	BIN FULL Sen TEST	Sensor On : BIN FULL SEN ON Display	
		Sensor Off : BIN FULL SEN OFF Display	
3	1	1'st CAST Solenoid Test	1: On, 2: Off
	2	MP Solenoid Test	1: On, 2: Off
	3	Duplex Solenoid Test	1: On, 2: Off
4	1	MHV Test	1: On, 2: Off (-1450v)
	2	DevBias Test	1: On, 2: Off (-450v)
	3	THV EN/NEG Test	1: On, 2: Off
	4	THV Test	1: On, 2: Off (1300v)
	5	THV Trigger Test	1: On, 2: Off
5	1	SCF Motor Test	1: On, 2: Off
	2	SCF Solenoid Test	1: On, 2: Off
	3	SCF Paper Empty Test	Sensor On : SCF Paper Empty Display
			Sensor Off : SCF Paper No Empty Display
4	SCF Installed Test	SCF installed : SCF READY ON	
		SCF not installed : SCF READY OFF	
6	1	All Function Test	For SMD Test, Push up key : Next function All Function : No.0~4



### 4-6-3 ENGINE PRINT

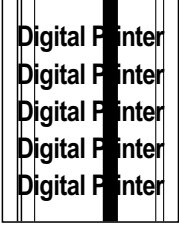
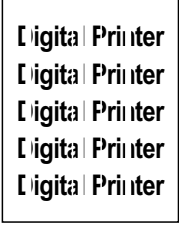
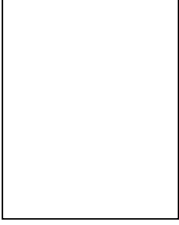

When the function is on, sentence to explain the condition of engine is printed in the below section of the printing output. It is needed in the development progress. Service person doesn't need to use it.4-7 Troubleshooting

## 4-7 Troubleshooting

### 4-7-1 Print Quality

Error Status	Check	Solution
<p>Vertical black line and band</p> 	<ol style="list-style-type: none"> <li>1. Bad blade of Toner cartridge</li> <li>2. LSU</li> </ol>	<ol style="list-style-type: none"> <li>1. Change Toner cartridge</li> <li>2. Replace LSU</li> </ol>
<p>Vertical white line</p> 	<ol style="list-style-type: none"> <li>1. LSU window contamination</li> <li>2. Toner cartridge</li> </ol>	<ol style="list-style-type: none"> <li>1. Clean LSU window</li> <li>2. If not LSU, change Toner cartridge.</li> </ol>
<p>No image</p> 	<ol style="list-style-type: none"> <li>1. Seal tape is removed?</li> <li>2. GND OPC is well grounded?</li> <li>3. LSU running well?</li> <li>4. Biss voltage is normal?</li> <li>5. Lower toner?</li> <li>6. Is there video data from Main PBA</li> </ol>	<ol style="list-style-type: none"> <li>1. Removing seal tipe</li> <li>2. Measure the resistance between frame ground and the ground spring attached frame. Confirm stable ground. Unless bad ground, detach cabinet, check where is bad point</li> <li>3. Adjust LSU or replace it</li> <li>4. Normal Dev bias = -350V</li> <li>5. Shake toner cartridge and print. If a liitke good, toner is empty</li> <li>6. Test engine test pattern , replace Main PBA</li> </ol>
<p>Light image</p> 	<ol style="list-style-type: none"> <li>1. Check seal tape removing</li> <li>2. LSU light power normal?</li> <li>3. Enough toner?</li> <li>4. High charger voltage?</li> <li>5. Lower bias voltage</li> <li>6. Contamination of high voltage contact.</li> <li>7. Transfer volatge and roller.</li> </ol>	<ol style="list-style-type: none"> <li>1. Check and remove tape</li> <li>2. LSU light power check is difficult. Compare with new one and check.</li> <li>3. Check toner and developer counter</li> <li>4~5. Measure all high voltage output.</li> <li>6. Leakage toner cause bad contact and increase contact resistance. Clean contami-nated area.</li> </ol>
<p>Dark image</p> 	<ol style="list-style-type: none"> <li>1. LSU light power normal?</li> <li>2. Bias voltage output is high?</li> <li>3. Video data is always supplied?</li> </ol>	<ol style="list-style-type: none"> <li>1. Check the rated level and replace.</li> <li>2. Set to power rating.</li> <li>3. Replace defected board.</li> </ol>

Error Status	Check	Solution
Background 	<ol style="list-style-type: none"> <li>1. High voltage output is normal?</li> <li>2. C/R of Toner cartridge is contaminated?</li> </ol>	<ol style="list-style-type: none"> <li>1. Adjust to the rated status.</li> <li>2. Replace Toner cartridge.</li> </ol>
Ghost 	<ol style="list-style-type: none"> <li>1. High voltage output.</li> <li>2. Pre-Transfer Lamp.</li> <li>3. Bad high voltage contact.</li> </ol>	<ol style="list-style-type: none"> <li>1. Check every high voltage.</li> <li>2. Check the turn-on PTL, LED crash.</li> <li>3. Clean the inside machine or replace toner cartridge.</li> </ol>
Stains on back of paper	<ol style="list-style-type: none"> <li>1. Contamination of transfer roller.</li> <li>2. Stains of paper path.</li> <li>3. Pressure roller's contamination.</li> </ol>	<ol style="list-style-type: none"> <li>1. Clean the transfer roller with vaccum cleaner.</li> <li>2. Clean the area of paper path with cloth or air cleaner.</li> <li>3. Remove fuser and replace it.</li> </ol>
Poor Fusing	<ol style="list-style-type: none"> <li>1. Use recommended paper?</li> <li>2. Check fusing temperature.</li> <li>3. The machine was under the low temperature for a long time?</li> </ol>	<ol style="list-style-type: none"> <li>1. Should use recommended paper.</li> <li>2. Check engine controller board. If you have not thermometer, measure the thermistor voltage to CPU, If <math>2.3V \pm 5\%</math> in printing CPU works well. Then, disassemble fuser and check the thermistor contact and thermistor.</li> <li>3. Re-check after putting the machine in the warm place for certain period.</li> </ol>
Partial blank image (not periodic)	<ol style="list-style-type: none"> <li>1. Toner is low?</li> <li>2. The toner cartridge is out of position?</li> </ol>	<ol style="list-style-type: none"> <li>1. Replace Toner cartridge.</li> <li>2. Check and adjust.</li> </ol>
Partial blank image (periodic)	<ol style="list-style-type: none"> <li>1. Develop roller scar or particle.</li> <li>2. Scar or particle. (94 mm)</li> <li>3. Transfer roller scar or particle . (47 mm)</li> </ol>	<ol style="list-style-type: none"> <li>1~2. Replace toner cartridge.</li> <li>3. Replace transfer roller.</li> </ol>

Error Status	Check	Solution
Different image density (left and right)  	1. Charge roller's pressure force unbalance 2. Dev. roller and OPC or Dev. roller and blade's pressure force unbalance 3. Transfer roller's pressure force unbalance of each side	1~2. Change toner cartridge  3. Check left and right spring of transfer roller and the spring pressing the developer inside the machine
Horizontal band  	1. Unstable high voltage contact  2. Charge roller's contamination 3. Contamination of heat roller 4. Malfunction of LSU	1. Clean each contact and check good contact 2. Clean charge roller 3. Replace fuser unit 4. Check Main PBA.

### Abnormal Image Printing and Defective Roller

If abnormal image prints periodically, check the parts shown below.

NO	Roller	Abnormal image period	Kind of abnormal image
1	OPC Drum	94.3 mm	White spot. Black spot
2	Charge Roller	37.7 mm	White spot. Black spot
3	Supply Roller	35.8 mm	Horizontal dark band
4	Develope Roller	44.8 mm	Horizontal dark band
5	Transfer Roller	57.8 mm	Black side contamination/transfer fault
6	Heat Roller	82.5 mm	Black spot, White spot
7	Pressure Roller	69.1 mm	Black side contamination

## No Image

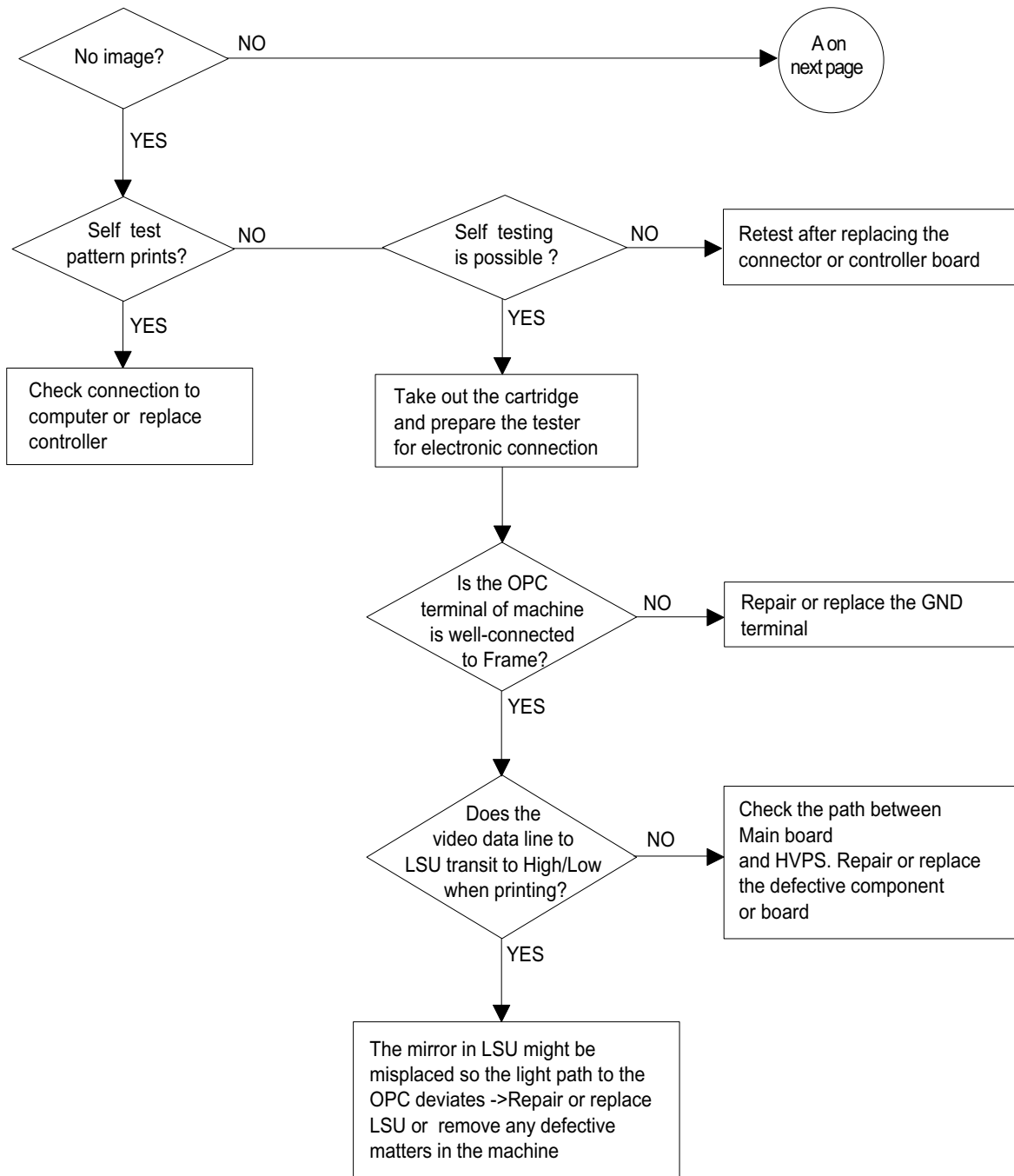
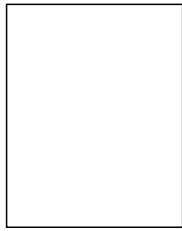

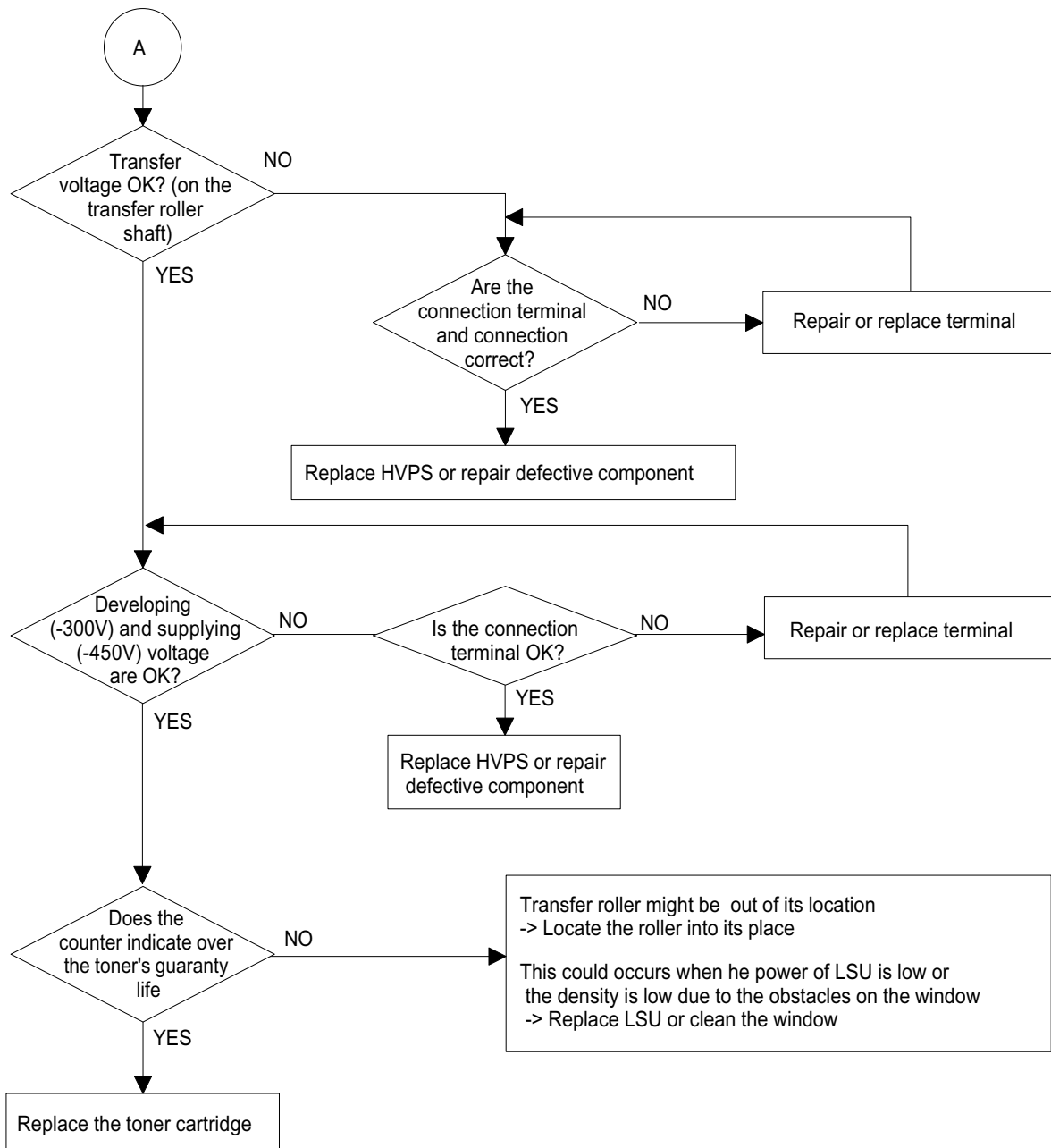

## All Black

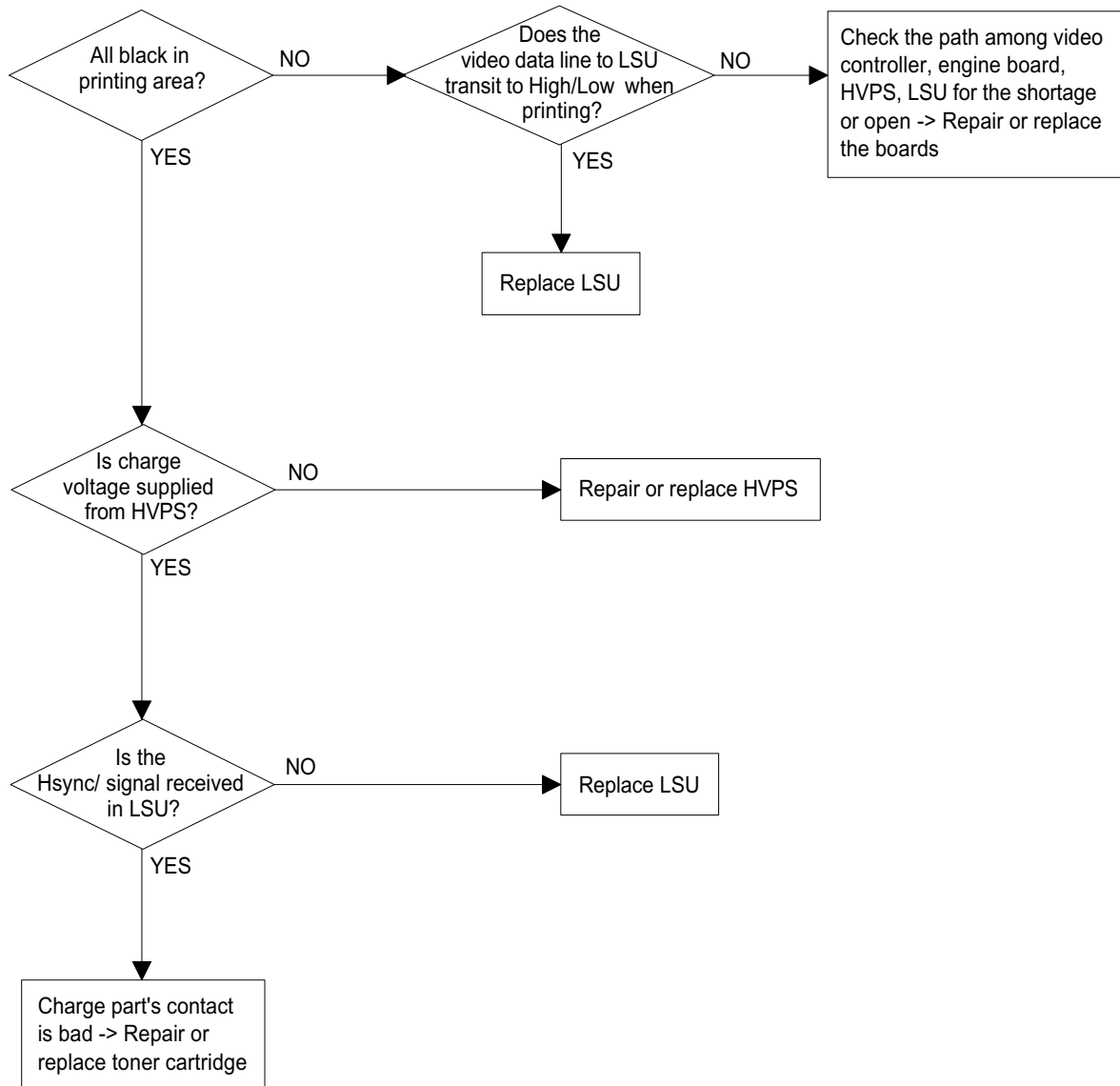
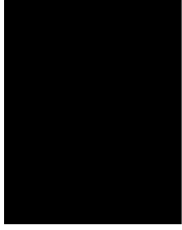

## Vertical White Line (Band)

Digital Printer  
Digital Printer  
Digital Printer  
Digital Printer  
Digital Printer

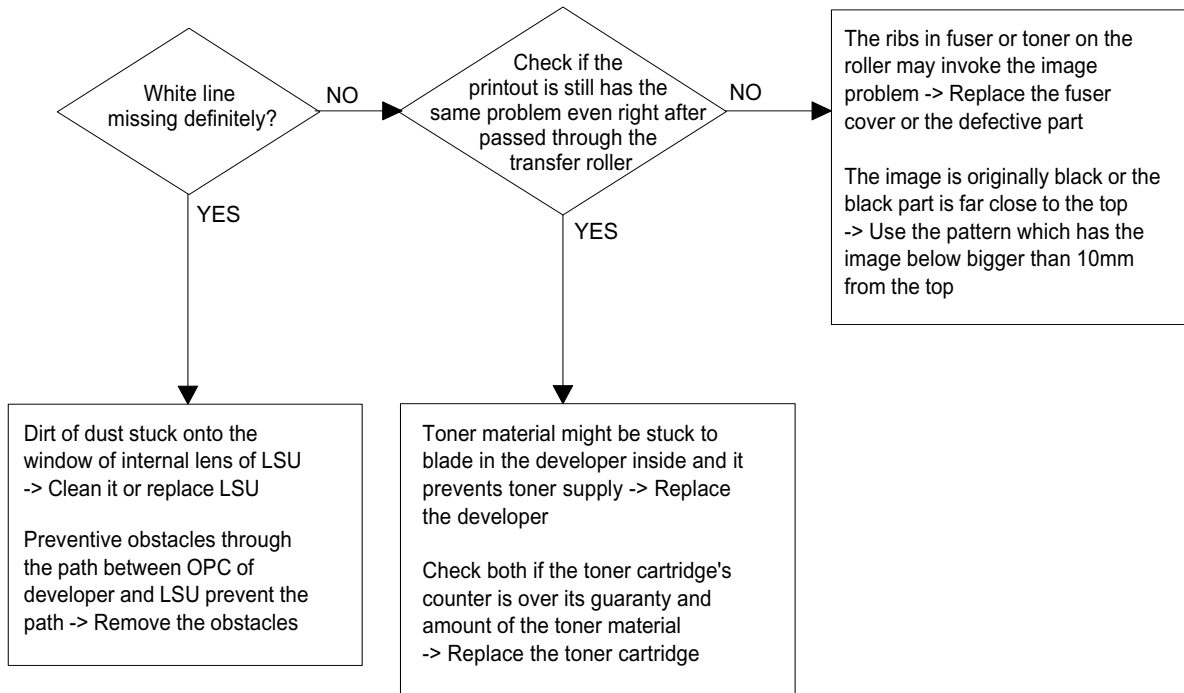

# Dark Image

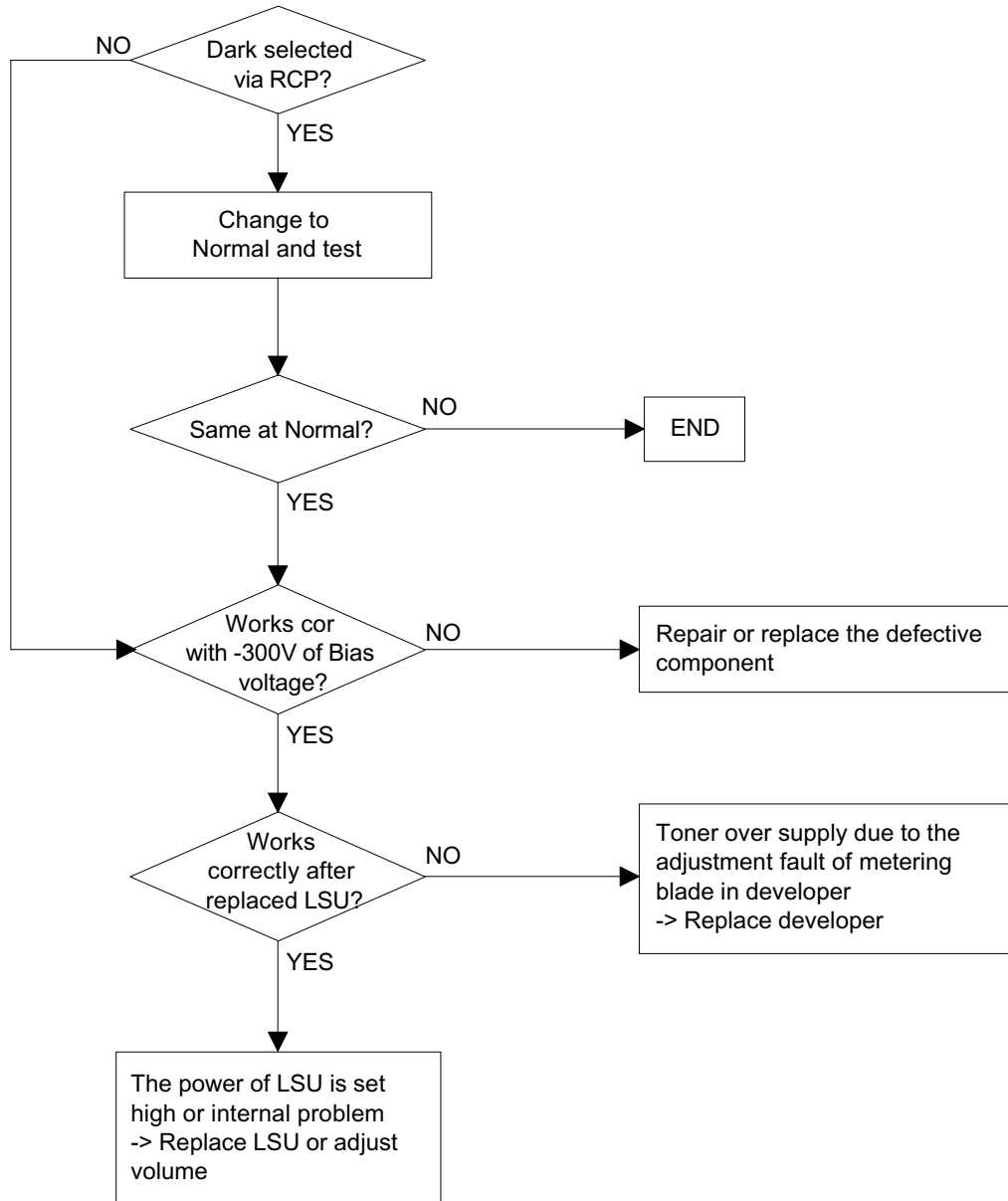
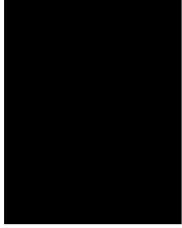

## Background

Digital Printer  
 Digital Printer  
 Digital Printer  
 Digital Printer  
 Digital Printer

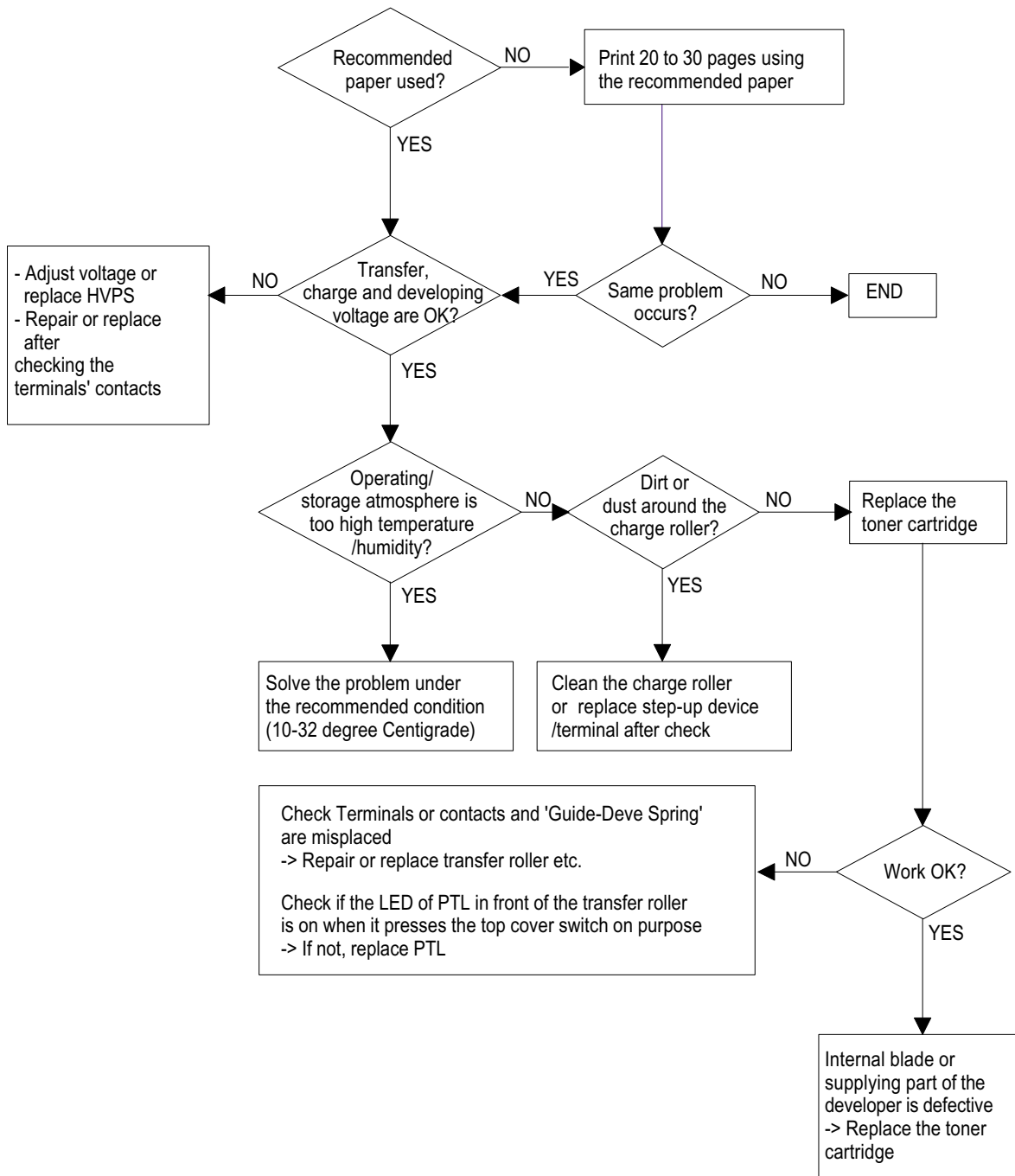

Ghost

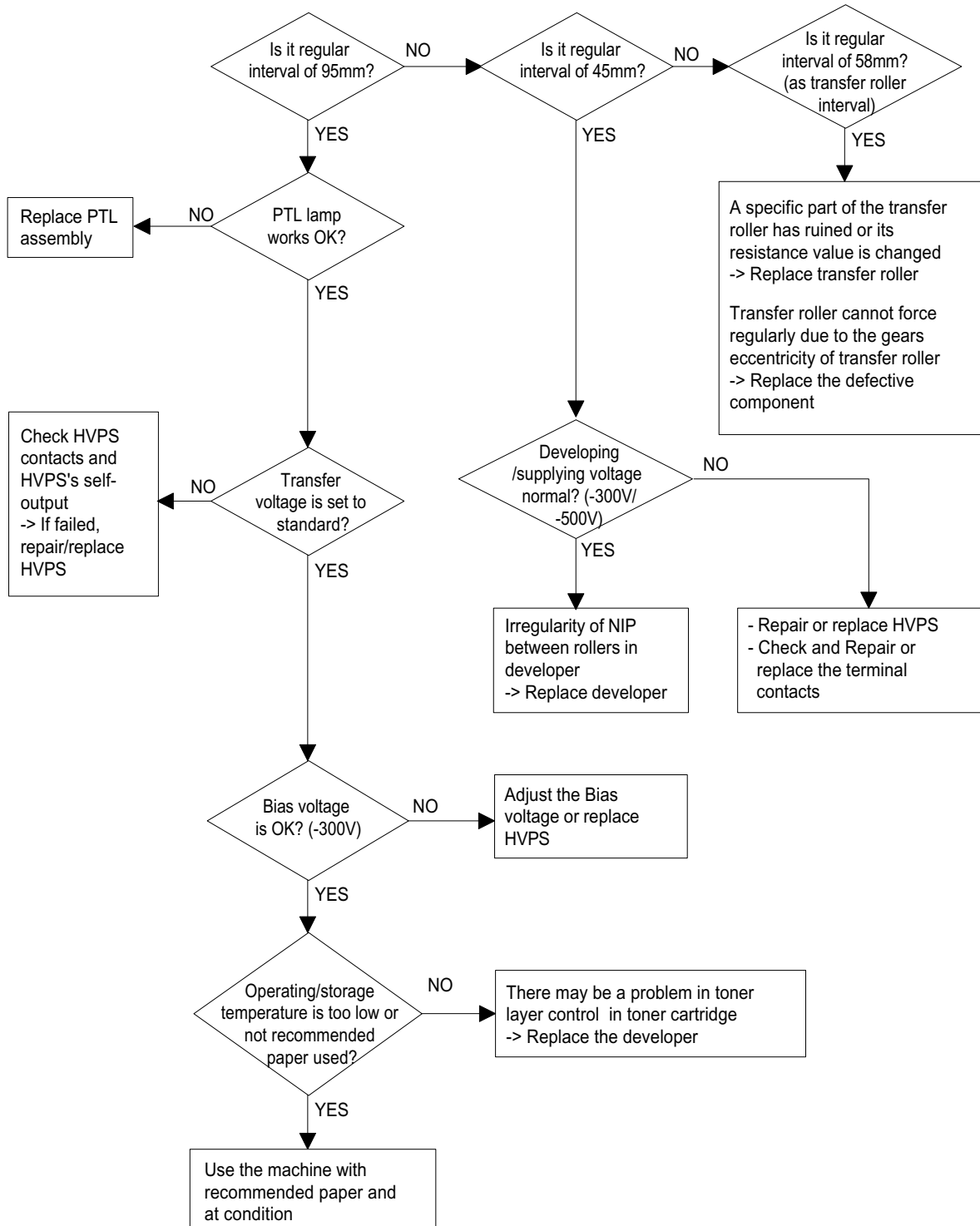

## Black Spot

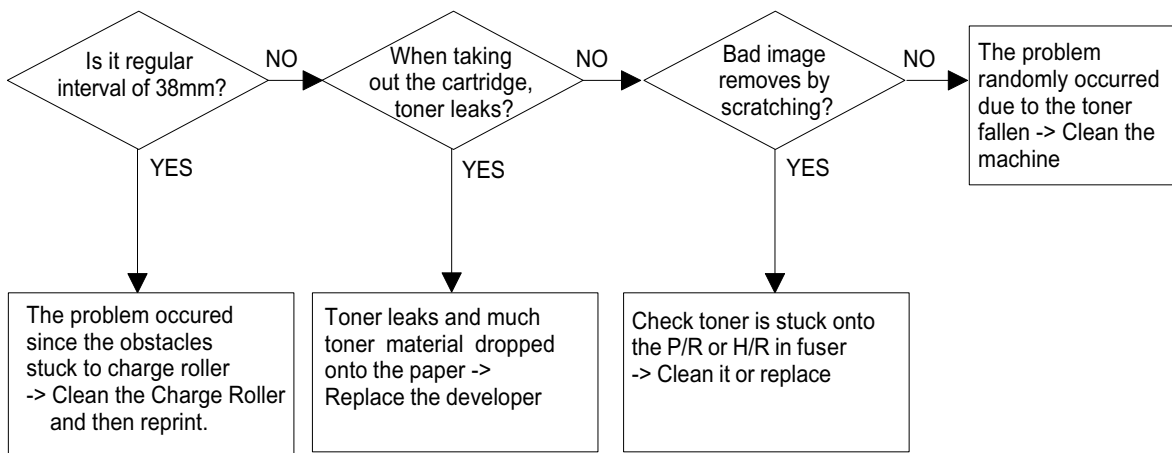

## Horizontal Band

<del>Digital Printer</del>	Digital Printer
Digital Printer	<del>Digital Printer</del>
Digital Printer	Digital Printer
<del>Digital Printer</del>	Digital Printer
Digital Printer	<del>Digital Printer</del>

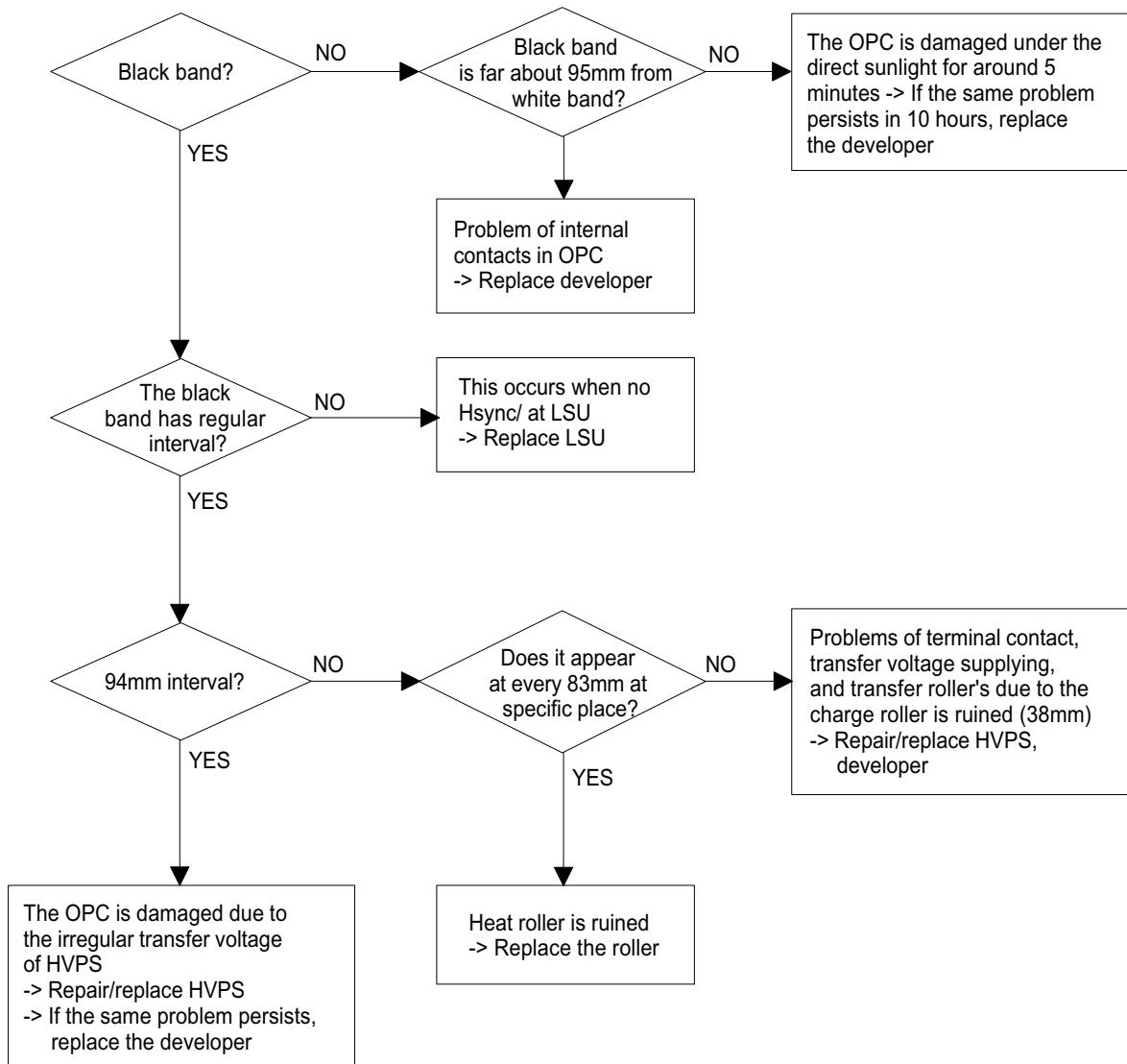

## Irregular Density

Digital Printer  
 Digital Printer  
 Digital Printer  
 Digital Printer  
 Digital Printer

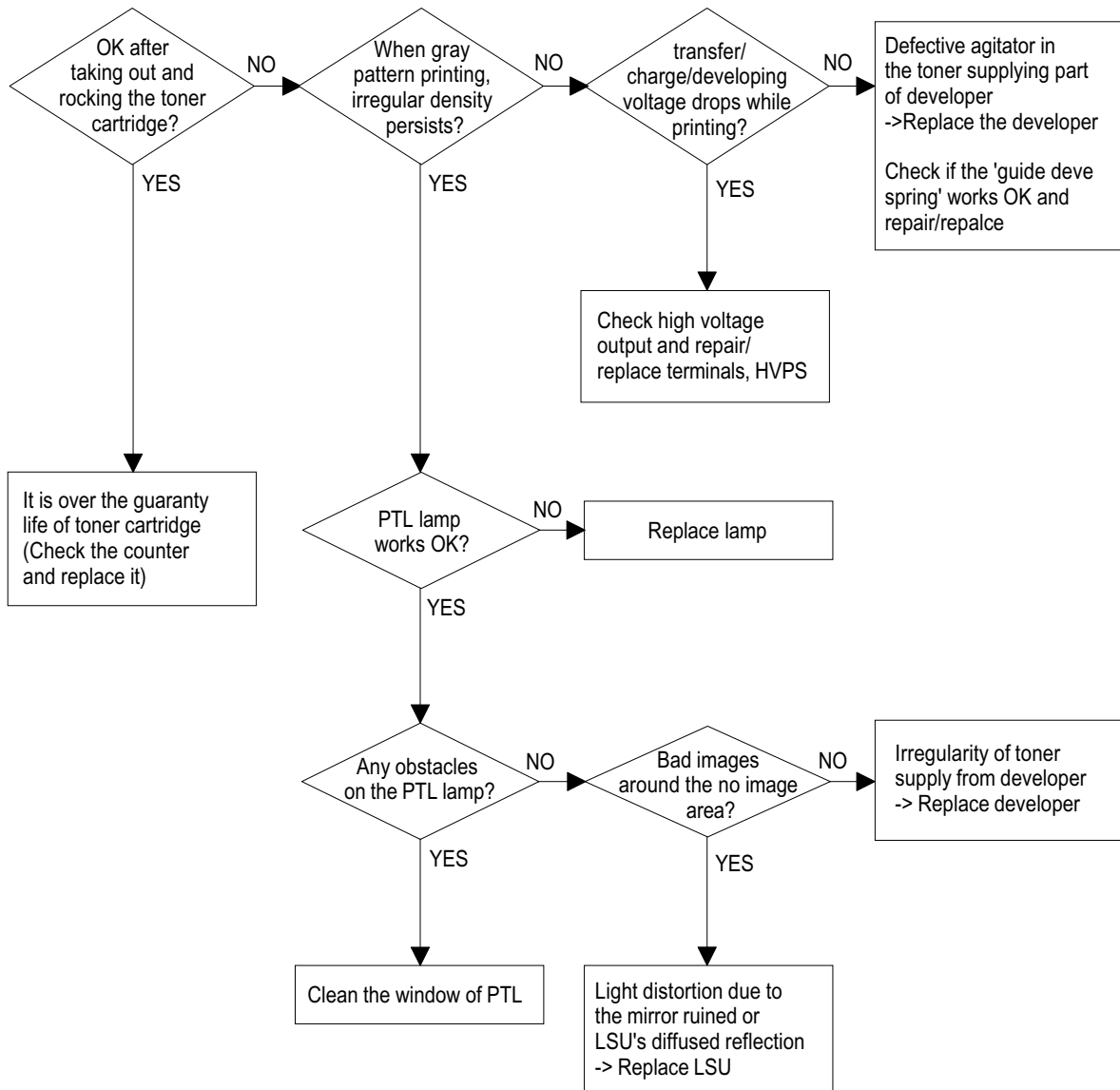

## White Spot

Digital Printer  
 Digital Printer  
 Digital Printer  
 Digital Printer  
 Digital Printer

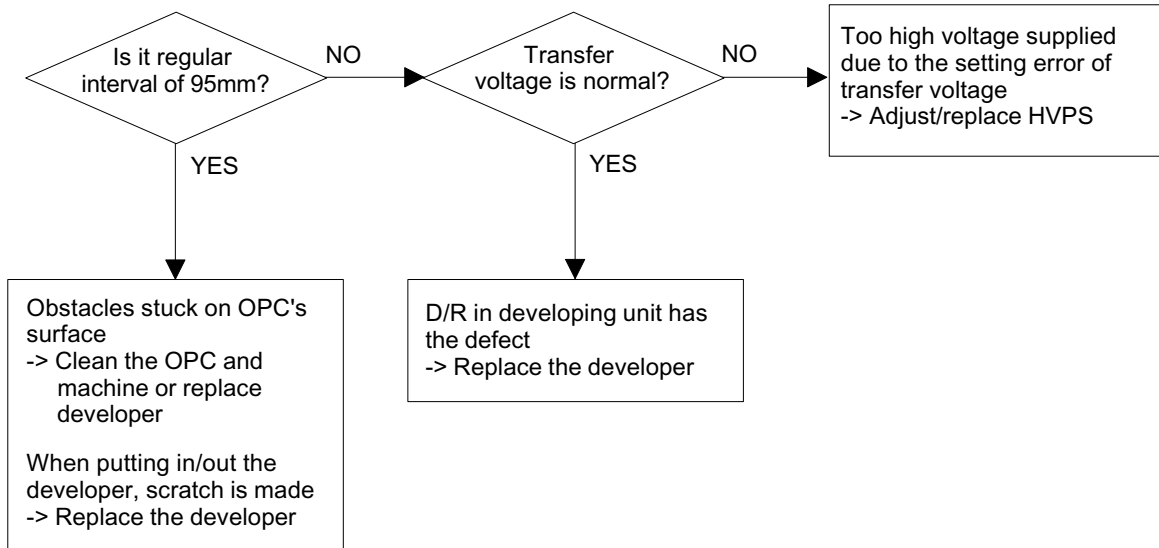

### Trembling at the End When OHP Print-

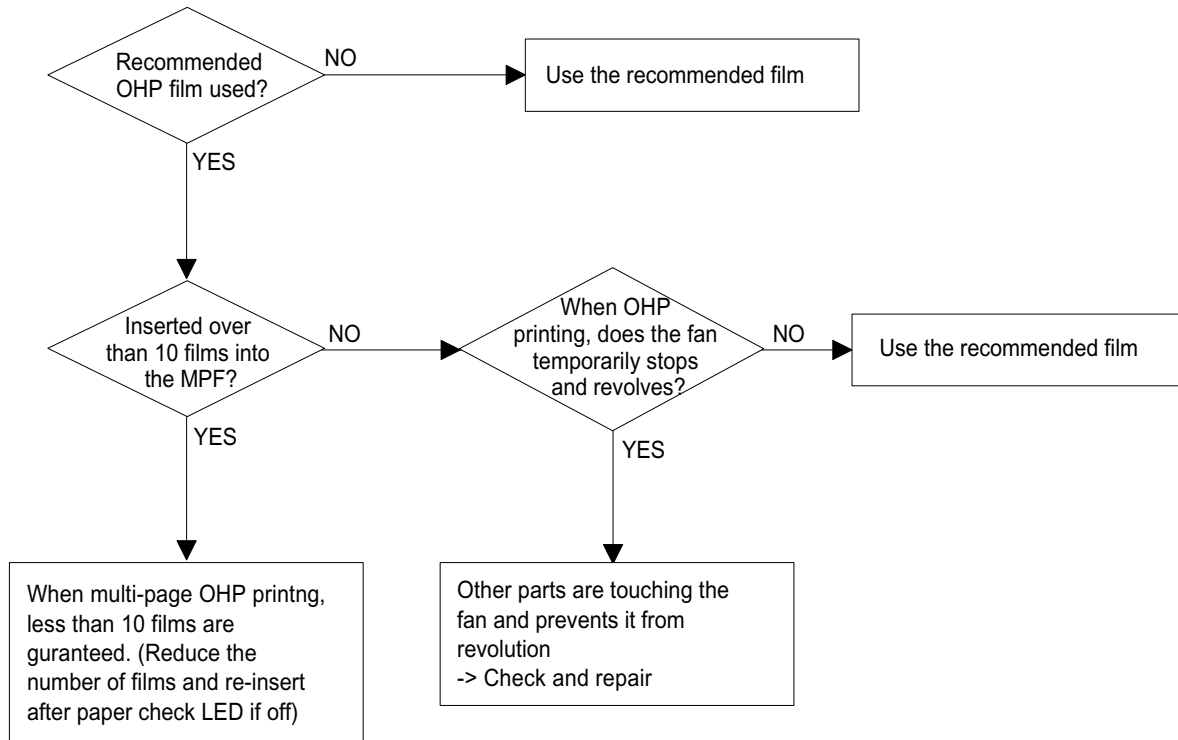

## Poor Fusing Grade

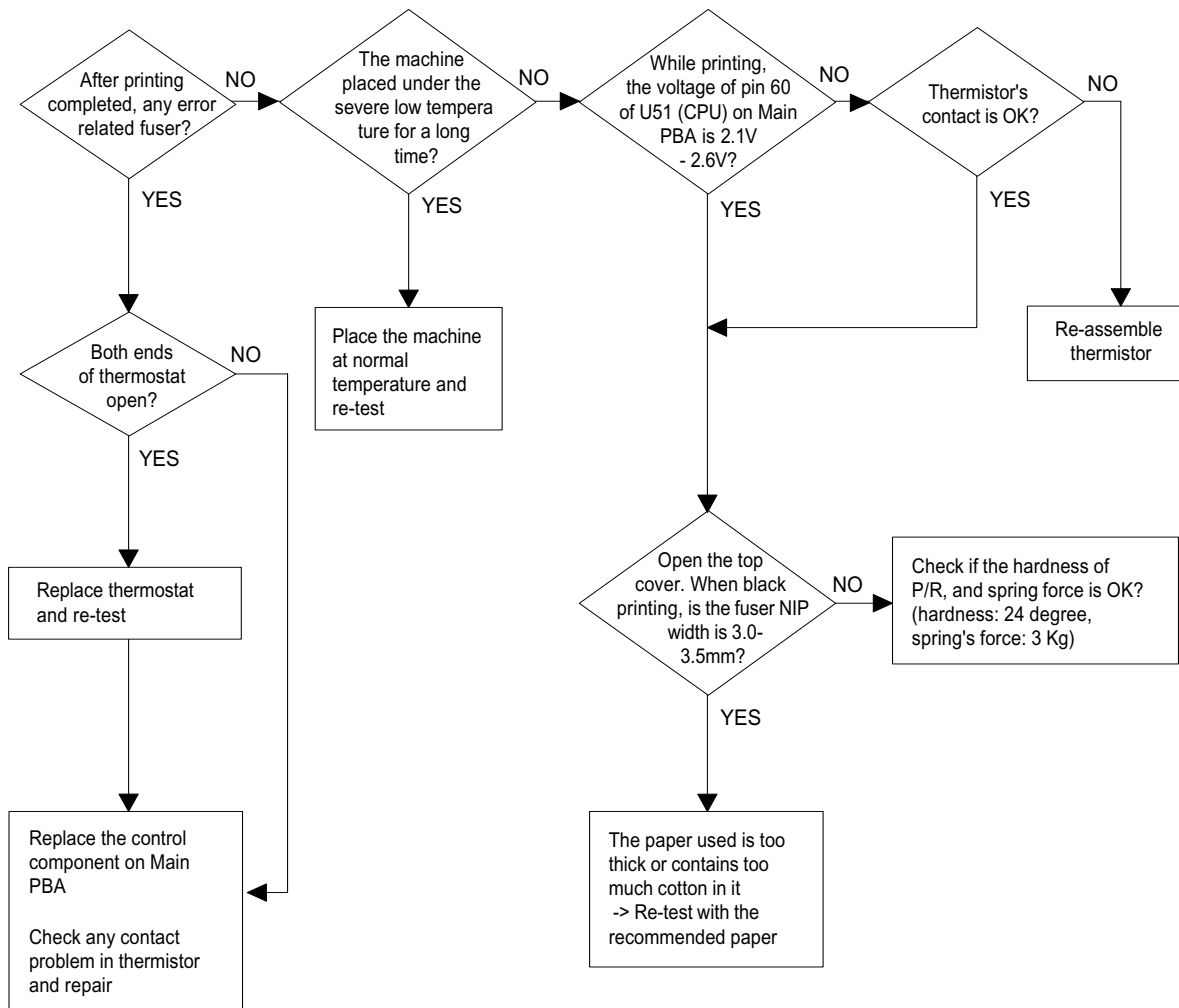

## 4-7-2 Malfunction

Error Status	Check	Solution
No power	<ol style="list-style-type: none"> <li>1. Check power is supplying</li> <li>2. Check fuse F1 open</li> </ol>	<ol style="list-style-type: none"> <li>1. If supplying power differs from machine's power rating, replace the machine.</li> <li>2. Replace it.</li> </ol>
Fuser Error	<ol style="list-style-type: none"> <li>1. Thermostat open</li> <li>2. AC wire open</li> <li>3. Thermistor wire open</li> <li>4. Main PBA</li> </ol>	<ol style="list-style-type: none"> <li>1. Detach AC connector and measure the resistance between pin 1 and 2. If it is megohm, thermostat is open, Replace it.</li> <li>2. Check bad connector contact or wire is cut.</li> <li>3. Check thermistor wire and its connection.</li> <li>4. Replace Main PBA</li> </ol>
Cover open	<ol style="list-style-type: none"> <li>1. When close Side cover, check the lever is pressed</li> <li>2. Micro switch's contact</li> <li>3. CPU and related circuit</li> </ol>	<ol style="list-style-type: none"> <li>1. Open Side cover and press the lever with pen. If Controller detects cover close, there is some mechanical trouble in Side cover and lever's assembly. If not so there is electrical problem.</li> </ol>
Jam 0	<p>Check where Jam 0 happens</p> <ol style="list-style-type: none"> <li>1. Paper is not picked up</li> <li>2. Paper is located in feed sensor</li> <li>3. Happened when inserting specific papers such as envelope into the MPF (Multipurpose Paper Feeder)?</li> <li>4. Happened when inserting specific papers such as envelope into the Manual Feeder?</li> <li>5. Is the Stacker Extender is folded out?</li> <li>6. Does not the Guide Adjust distort the papers</li> </ol>	<ol style="list-style-type: none"> <li>1. Check whether solenoid is working or not by using Engine test mode</li> <li>2. Check feed sensor malfunction.</li> <li>3. Re-try inserting a fewer papers. <ul style="list-style-type: none"> <li>•fan the papers and align</li> <li>•take out the loaded papers and insert them reverse direction</li> </ul> </li> <li>4. Take out the loaded papers and insert them reverse direction <ul style="list-style-type: none"> <li>•inserted papers as recommended for Manual Feeding? <ul style="list-style-type: none"> <li>•When loading, tap the papers until paper detect sensor senses loading</li> </ul> </li> </ul> </li> <li>5. When using long papers, use the Stacker Extender</li> <li>6. Adjust Guide to fit the paper width</li> </ol>
Jam 1	<p>Paper is stopped in just after of fuser unit.</p>	<ol style="list-style-type: none"> <li>1. It is mostly resulted from double feeding. Check paper is well stocked in feeder.</li> <li>2. Check feed actuator position and actuator's operating. There may be stiff movind or double reflection. If not so, check the operation of feed sensor by Engine test mode.</li> <li>3. Check exit lever operation. Remore jam and check actuator moving by hand. If actuator is too stiff, paper is wrapped around the heat roller. Remove obstacles or replace.</li> </ol>
Jam 2	<p>Check where Jam 2 happens</p> <ol style="list-style-type: none"> <li>1. Paper is curled and cannot exit.</li> <li>2. Paper is curled in the exit cover?.</li> </ol>	<ol style="list-style-type: none"> <li>1. Remove paper using pinset or some tool and watch if separate claws have any trouble. Clean around fuser.</li> <li>2. Check locking works wells. Watch whether the ribs of exit cover hace any burr or resisitive edge. If they do, remove obstacles or replace.</li> </ol>

Error Status	Check	Solution
Jam 2 at face-down tray	<ol style="list-style-type: none"> <li>1. Then paper is not drawn in because of the stack of papers in the Out tray.</li> <li>2. Does it curl while coming out?</li> </ol>	<ol style="list-style-type: none"> <li>1. Load recommended quantity of papers</li> <li>2. Open the Cover Front and check whether roller or spring, which are related to paper out, is not out of position. If so, re-locate or replace.</li> </ol>
Clutch error	<ol style="list-style-type: none"> <li>1. Check the spring of solenoid</li> <li>2. Check the armature assembly/cushion</li> <li>3. Electrical check</li> </ol>	<ol style="list-style-type: none"> <li>1. Check whether the spring is expanded or not.</li> <li>2. Check armature is well installed. It may be unstable assemble.</li> <li>3. Remove the Main PBA.</li> </ol>
High voltage error	<ol style="list-style-type: none"> <li>1. Check the terminal output voltage</li> <li>2. Check HVPS</li> </ol>	<ol style="list-style-type: none"> <li>1. Remove the Toner cartridge and open the cover and press cover open switch lever and measure the voltage with high voltage probe and sending printing data. If the voltage is normal, change the toner cartridge.</li> <li>2. Disassemble the left side cover, and check HV of the solder side of HVPS and change it.</li> </ol>
Feeding obstacles	Does the Plate-knockup prevent the paper loading?	<p>MPF :</p> <p>Turn the power off and on. Open and close the Side cover to return to the original state.</p> <p>Cassette :</p> <p>Adjust Guide to fit the paper width.</p>
Skew	Is the Guide adjust set to the paper width?	Fit the paper width using the Guide adjust.
Stacking	<ol style="list-style-type: none"> <li>1. Took out the Stacker extender to support long papers?</li> <li>2. Stacked too many papers more than Stacker can hold?</li> </ol>	<ol style="list-style-type: none"> <li>1. Use extender as per the paper length.</li> <li>2. The Face-up stacker normally can hold 100 pages when using 75g/m2, however, stacking capacity can be lowered depending on the type of papers.</li> </ol>
Engine Error	Check CBF Harness_CN1. (Main PBA to LSU)	Refer to troubleshooting "ENGINE ERROR".
Document Jam	Document is not picked up(in ADF).	<ol style="list-style-type: none"> <li>1. Check document is well stocked in ADF.</li> <li>2. Check whether document was been fastened together by staple or clip.</li> <li>3. Load recommended quantity of papers.</li> </ol>
	Document is stopped after it has fed into the ADF.	<ol style="list-style-type: none"> <li>1. Check whether the Reg. sensor is working or not.</li> <li>2. Check whether the Feed Roller is working or not.</li> </ol>
	Does it curl while coming out?	<ol style="list-style-type: none"> <li>1. Check the Open Cover whether there are bosses.</li> <li>2. Check the ADF ass'y is well assemble.</li> </ol>

## No Power (LCD NO display LED Off)

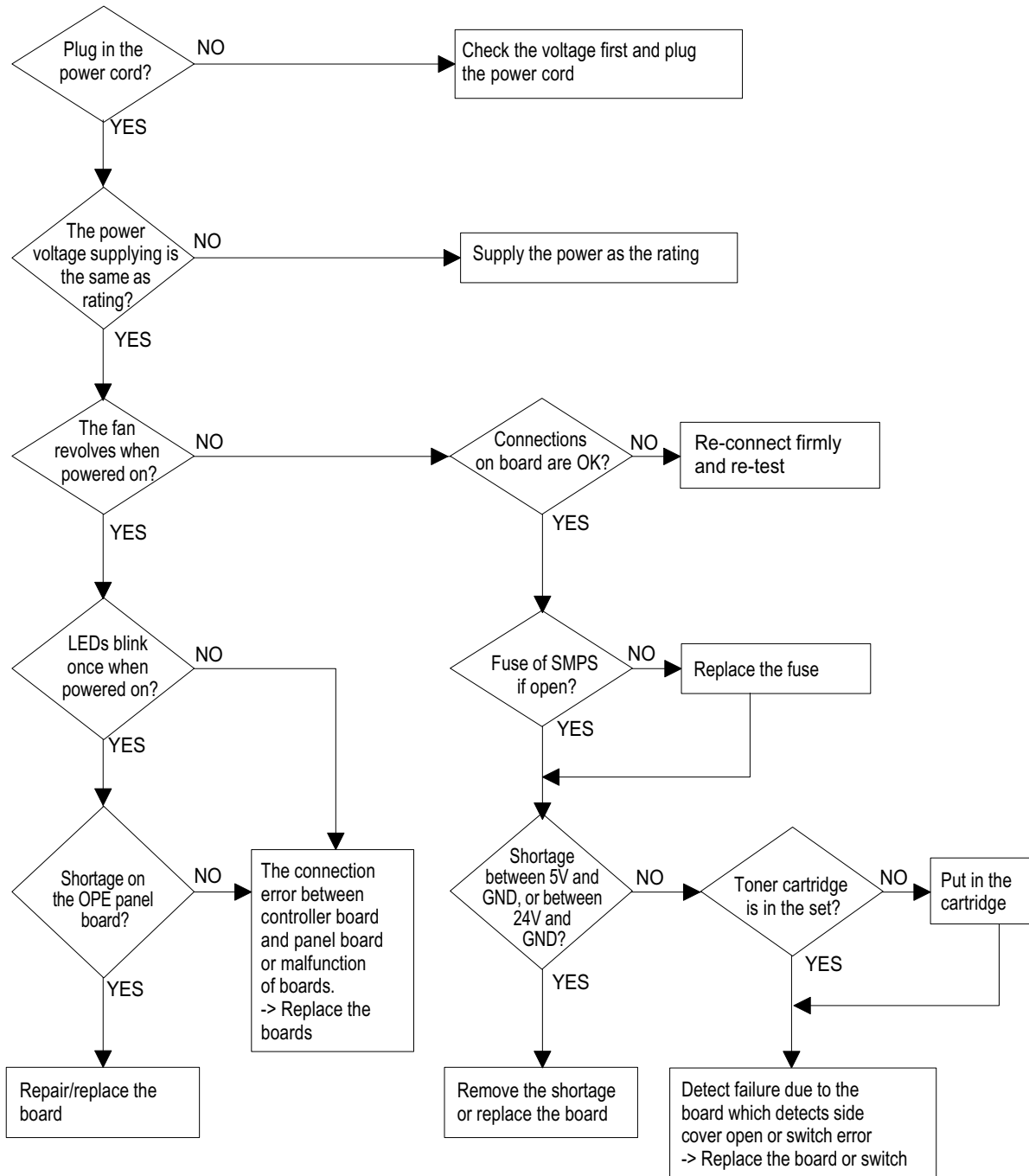

## Fuser Error

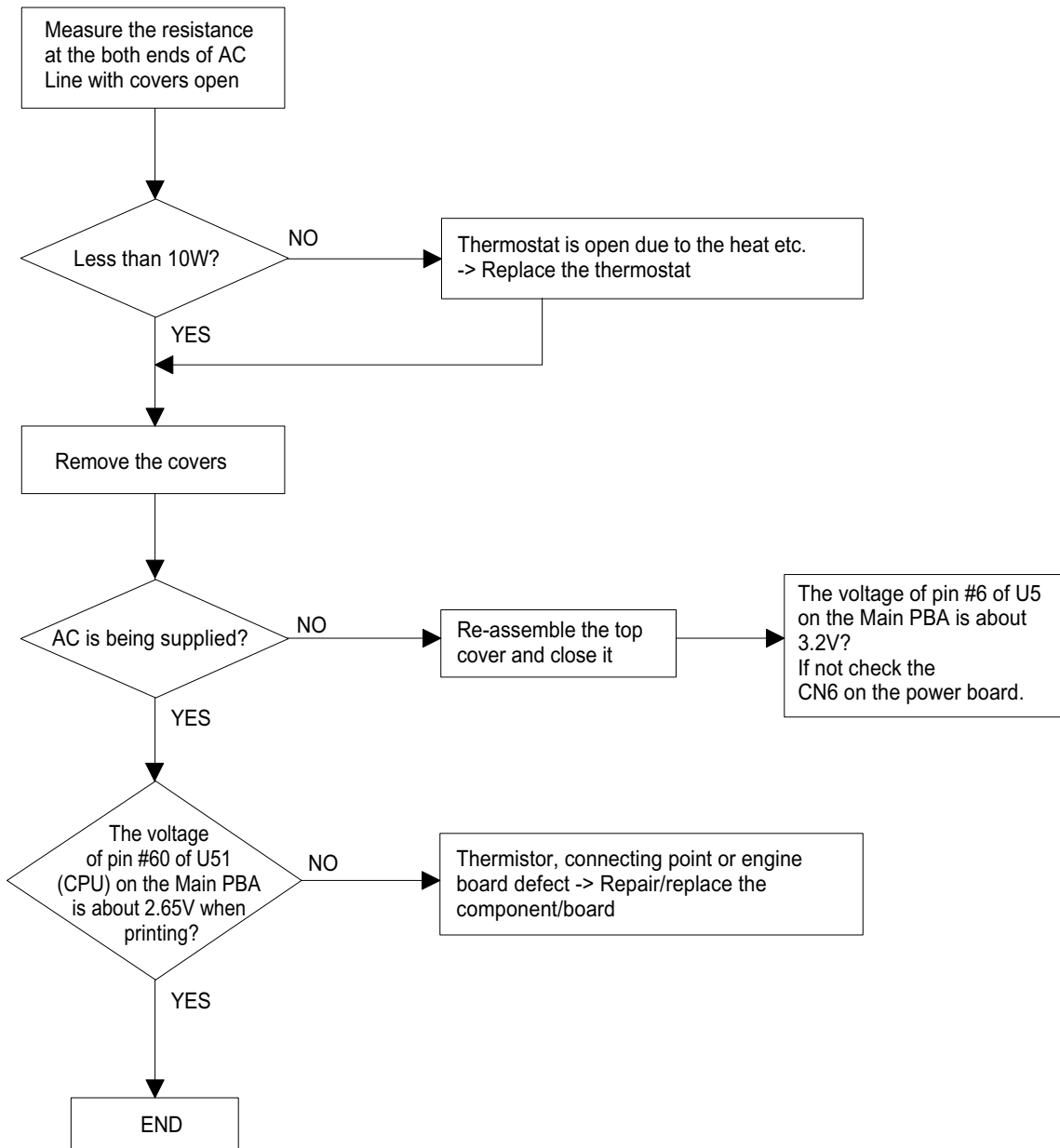

## Paper Jam (Mis-Feeding)

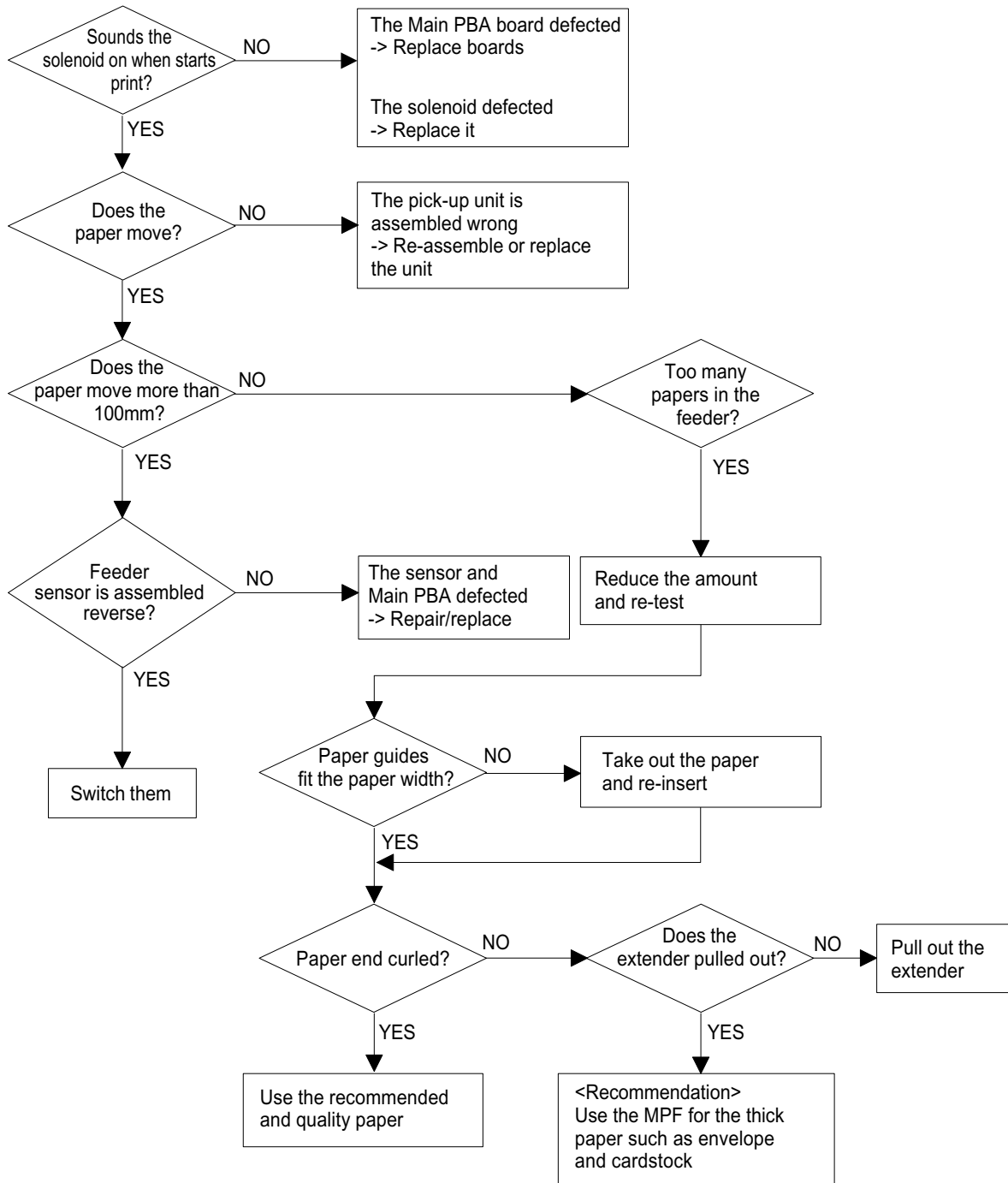

## Paper Jam(Jam 1)

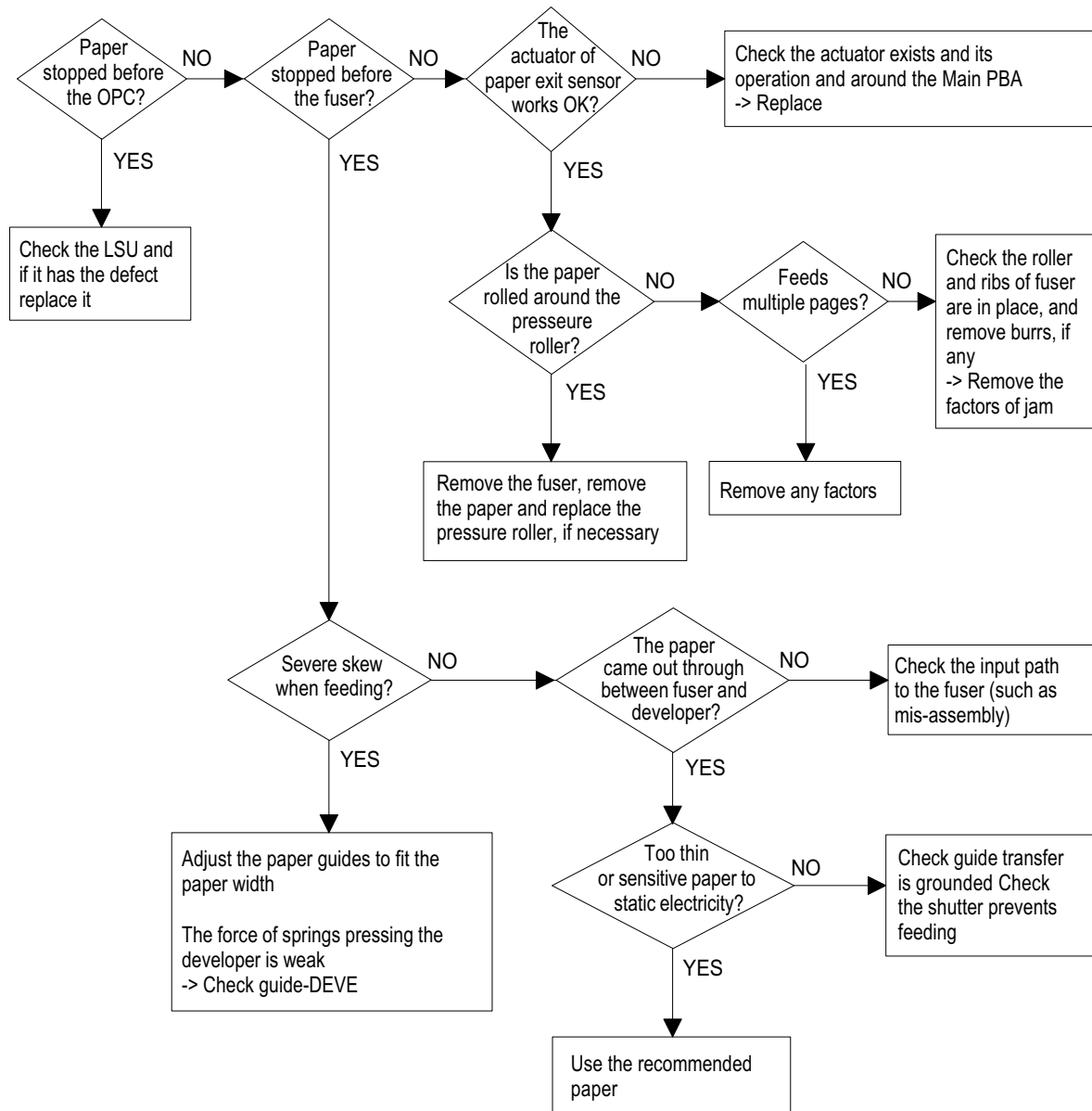

# Engine Error

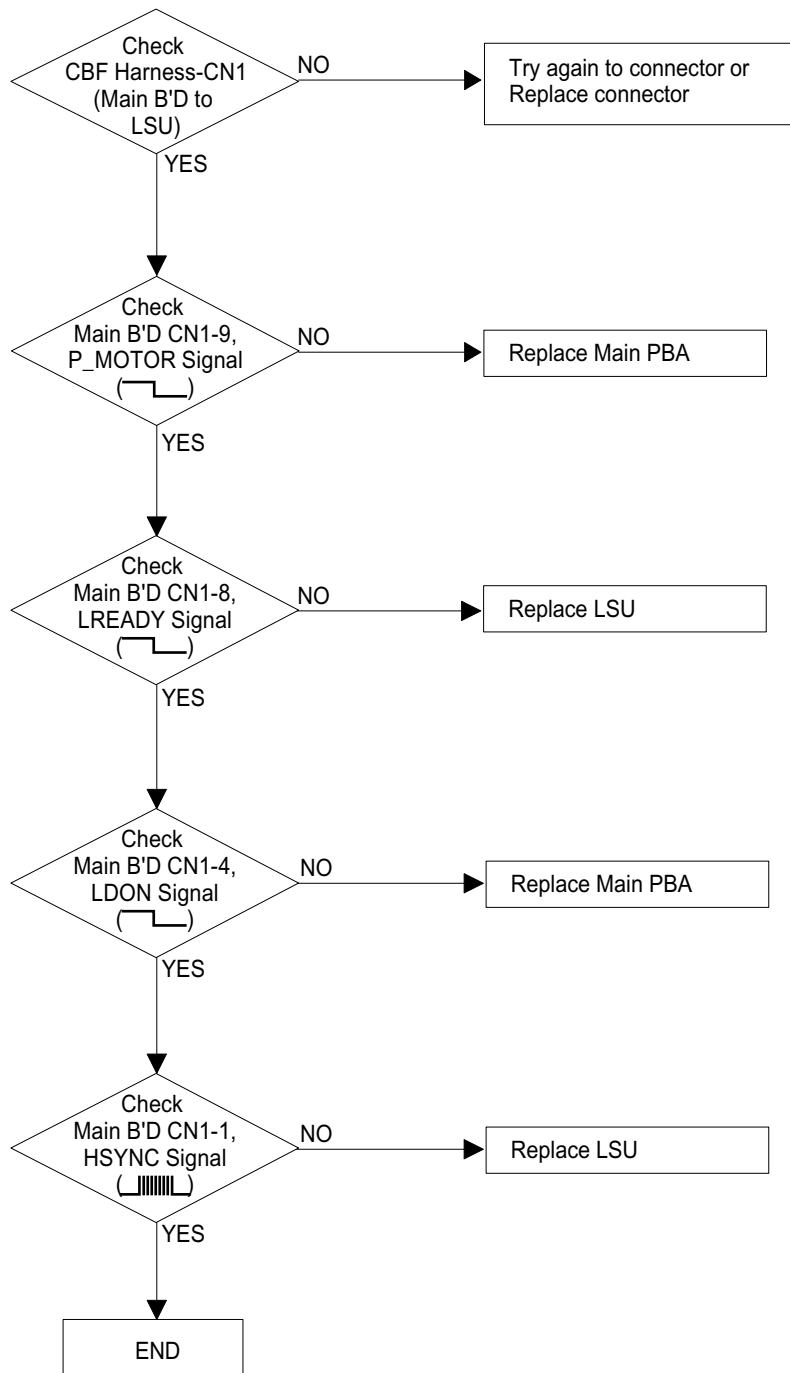

## **4-7-3 Toner Cartridge and Drum Cartridge Service**

It is not guaranteed for the default caused by using other toner and Drum Cartridge cartridge other than the cartridge supplied by the Samsung Electronic or caused by non-licensed refill production.

### **Precautions on Safe-keeping of the Drum Cartridge**

---

Excessive exposure to direct light more than a few minutes may cause damage to the cartridge.

### **Service for the Life of Toner Cartridge**

---

If the printed image is light due to the life of the toner, you can temporarily improve the print quality by redistributing the toner(Shake the toner cartridge), however, you should replace the toner cartridge to solve the problem thoroughly.

### **Service for Judgement of Inferior Expendables and the Standard of Guarantee**

---

Please refer to User's Manual or Instructions on Fax/Printer Expendables SVC for the judgement of inferior expendables and the standard of guarantee besides this service manual.

### 4-7-3-1 Signs and Measures at Poor toner cartridge

Fault	Signs	Cause & Check	Solution
<p>Light image and partially blank image (The life is ended.)</p> <div style="border: 1px solid black; padding: 5px; margin-top: 10px;"> <p>Digital Printer Digital Printer Digital Printer Digital Printer Digital Printer</p> </div>	<ul style="list-style-type: none"> <li>• The printed image is light or unclean and untidy.</li> <li>• Some part of the image is not printed.</li> <li>• Periodically a noise as "tick tick" occurs.</li> </ul>	<ol style="list-style-type: none"> <li>1. If the image is light or unclean and untidy printed image - Shake the developer and then recheck. (1)NG: Check the weight of the developer (2)OK: Lack of toner, so the life is nearly closed.</li> <li>2. Some part of image is not printed - Shake the developer and then recheck. (1)NG: Check the weight of the developer and clean the LSU window with a cotton swab, then recheck. (2)OK: Lack of toner, so the life is nearly closed.</li> <li>3. Periodically a noise as "tick tick" occurs - Measure the cycle and the weight of the developer.</li> <li>4. White vertical stripes on the whole screen or partly : Check the weight of the developer.</li> </ol>	<ol style="list-style-type: none"> <li>1. All of 1, 2, 3 above- If it become better by shaking, replace with a new developer after 50-100 sheets in the closing state of the life span.</li> <li>2. In case of 2- If it becomes better after cleaning the LSU window, then the developer is normal. (Because of foreign substance on the LSU window, the image has not been printed partly.)</li> <li>3. In case of 3- If the cycle of noise is about 2 seconds, the toner inside the developer has been nearly exhausted. ( Purchase and replace with a new developer after using about 200 sheets at the point of occurrence)</li> <li>4. In case of 3- This is a phenomenon caused by lack of toner, so replace with a new developer.</li> </ol>
<p>Toner Contamination</p>	<ul style="list-style-type: none"> <li>• Toner is fallen on the papers periodically.</li> <li>• Contaminated with toner on prints partly or over the whole surface.</li> </ul>	<ol style="list-style-type: none"> <li>1. Toner is fallen on the paper periodically. (1)Check the cycle of the falling of the toner. (2)Check the appearance of both ends of the developer OPC drum.</li> <li>2. The center of the printed matter is contaminated with toner. (1)Check whether foreign substances or toner are stuck to the terminal (contact point) of the developer. (2)Check whether the state of the terminal assembly is normal.</li> </ol>	<ol style="list-style-type: none"> <li>1. If both ends of the OPC drum are contaminated with toner: Check the life of the developer.</li> <li>2. Check whether it could be recycled.</li> </ol>

Fault	Signs	Cause & Check	Solution
<p>White Black spot</p> 	<ul style="list-style-type: none"> <li>• Light or dark black dots on the image occur periodically.</li> <li>• White spots occur in the image periodically.</li> </ul>	<ol style="list-style-type: none"> <li>1. If light or dark periodical black dots occur, this is because the developer rollers are contaminated with foreign substance or paper particles.               <ul style="list-style-type: none"> <li>(1)37.7mm interval : Charged roller</li> <li>(2)94.3mm interval : OPC cycle</li> </ul> </li> <li>2. If white spots occur in a black image at intervals of 94, 29mm, or black spots occur elsewhere, the OPC drum is damaged or foreign substance is stuck to the surface.</li> <li>3. If a black and white or graphic image is partially broken at irregular intervals, the transfer roller's life has been expired or the transfer voltage is abnormal.</li> </ol>	<ol style="list-style-type: none"> <li>1. In case of 1 above -               <ul style="list-style-type: none"> <li>Run OPC Cleaning Mode Print 4-5 times repeatedly to remove. Especially check foreign substance on the OPC surface, then remove them with a clean gauze moistened with IPA(Isopropyl Alcohol) not to damage OPC if necessary.</li> <li>Caution : Never use usual alcohol.</li> </ul> </li> <li>2. In case of 2               <ul style="list-style-type: none"> <li>If they are not disappeared by running OPC Cleaning Mode Print 4-5 times.                   <ul style="list-style-type: none"> <li>: at intervals of 94.3mm - Replace the developer.</li> <li>: at intervals of 37.7mm - Remove foreign substance, Clean the Charged Roller</li> <li>: Broken image - Replace the developer according to carelessness.</li> </ul> </li> </ul> </li> <li>3. In case of 3 - Exchange the transfer roller because the life of the transfer roller in use has been expired. (Check the transfer voltage and readjust if different.)</li> </ol>
<p>Recycled product</p>	<ul style="list-style-type: none"> <li>• Poor appearance of the developer.</li> <li>• Unclean and rough printouts.</li> <li>• Bad background in the image.</li> </ul>	<ol style="list-style-type: none"> <li>1. Poor appearance of the developer.               <ul style="list-style-type: none"> <li>(1)Check the damage to label and whether different materials are used.</li> <li>(2)Check the appearance of parts of the developer, such as frame, hopper.</li> </ul> </li> <li>2. Unclean and rough printouts.               <ul style="list-style-type: none"> <li>(1)Check whether foreign substance or toner are stuck to the terminal (contact point) of the developer.</li> <li>(2)Check whether the state of the terminal assembly is normal.</li> </ul> </li> </ol>	<ol style="list-style-type: none"> <li>1. In case of 1 -               <ul style="list-style-type: none"> <li>(1)If there is an evidence of disassembling the developer.</li> <li>(2)If materials other than normal parts of the developer are added or substituted.</li> </ul> </li> <li>2. In case of 2 - If there are any abnormalities in connection with the situation of 1.               <ul style="list-style-type: none"> <li>(1)It occurs when the developer is recycled over 2 times.</li> <li>(2)If toner nearly being expired are collected to use, it is judged as the recycled developer.</li> </ul> </li> </ol>

Fault	Signs	Cause & Check	Solution
<p>Ghost &amp; Image Contamination</p>	<ul style="list-style-type: none"> <li>• The printed image is too light or dark, or partially contaminated black.</li> <li>• Totally contaminated black. (Black image printed out)</li> </ul>	<p>1. The printed image is too light or dark, or partially contaminated black.</p> <p>(1) Check whether foreign substance or toner are stuck to the terminal (point of contact) of the developer.</p> <p>(2) Check whether the terminal assembly is normal.</p> <p>2. Totally contaminated black. (Black image printed out)</p> <p>(1) Check whether foreign substances are stuck to the terminal (point of contact) of the developer and the state of assembly. (Especially check the charged roller terminal.)</p>	<p>1. All of 1, 2, 3 above</p> <p>(1) Remove toner and foreign substances adhered to the contact point of the developer.</p> <p>(2) The contact point of the unit facing that of the developer also must be cleaned.</p> <p>(3) If the terminal assembly is unsafe:</p> <ul style="list-style-type: none"> <li>• Fully stick the terminal to or reassemble it after disassembling.</li> <li>• Disassemble the side plate and push the terminal to be stuck, then reassemble it.</li> </ul> <p>2. In case of 2</p> <p>It is a phenomenon when the OPC drum of the developer is not electrically charged. Clean the terminals of the charged roller, then recheck it.</p>

## 4-7-4 The cause and solutions of bad environment of the software

### 4-7-4-1 The printer is not working (1)

- **Description** : While Power turned on, the printer is not working in the printing mode.

Check and Cause	Solution
<p>1. Check if the PC and the printer is properly connected and the toner cartridge installed.</p> <p>2. Printing is nor working in the Windows.</p> <p>3. Check if the printer cable is directly connected to peripheral devices</p>	<p>1. Replace the printer cable. If the problems not solved even after the cable replaced, check the amount of the remaining tone.</p> <p>2. Check if the connection between PC and printer port is proper. If you use windows, check if the printer driver in the controller is set up. If the printer driver is properly set up, check in which program the printing is not working. The best way to find out is to open the memo pad to check the function of printing. If it is not working in a certain program, adjust the setup the program requires. Sometimes, the printout is normal within the Windows basic programs, but it's not working in a particular program. In such case, install the new driver again. If not working in the Windows basic program, Check the setup of the port of CMOS is on ECP. And check the address of IRQ 7 and 378</p> <p>3. If the scanner needs to be connected to the printer, first the remove the scanner from the PC to see if the printer is properly working alone.</p>

### 4-7-4-2 The printer is not working (2)

- **Description** : After receiving the printing order, no response at all or the low speed of printing occurs due to wrong setup of the environment rather than malfunction of the printer itself.

Check and Cause	Solution
<p>1. Secure more space of the hard disk.</p> <p>2. Printing error occurs even if there is enough space in the hard disk.</p> <p>3. Check the parallel-port-related items in the CMOS Setup.</p> <p>4. Reboot the system to print.</p>	<p>1. Not working with the message 'insufficient printer memory' means hard disk space problem rather than the RAM problem. In this case, provide more space for the hard disk. Secure more space using the disk utilities program.</p> <p>2. The connection of the cable and printer port is not proper. Check if the connection is properly done and if the parallel port in CMOS is rightly set up.</p> <p>3. As a printer port, Select ECP or SPP among SPP(Normal), ECP, and EPP modes(increase printing speed) SPP normal mode support 8-bit data transfer, while ECP Mode transfer the 12-bit data.</p> <p>4. If the regular font is not printing, the cable or the printer driver may be defective. Turn the PC and printer off, and reboot the system to print again. If not solved, double-click the printer in my computer. If the regular fonts are not printed this time again. the cable must be defective so replace the cable with new one.</p>

### 4-7-4-3 Abnormal Printing

- **Description :** The printing is not working properly even when the cable has no problem. (even after the cable is replaced) If the printer won't work at all or the strange fonts are repeated, the printer driver may be defective or wrong setup in the CMOS Setup.

Check and Cause	Solution
1. Set up the parallel port in the CMOS SETUP.	1. Select SPP(Normal) or ECP LPT Port the among ECP, EPP or SPP in the CMOS Setup.
2. Printer Driver Error.	2. Check the printer in My Computer.(to see if the printer driver is compatible to the present driver or delete the old driver, if defective and reinstall the new driver)
3. Error message from insufficient memory. (The printing job sometimes stops or due to insufficient virtual memory, but it actually comes from the insufficient space of the hard disk.)	3. Delete the unnecessary files to secure enough space of the hard disk and start printing job again.

### 4-7-4-4 SPOOL Error

- **Description :** To spool which stands for "simultaneous peripheral operations online" a computer document or task list (or "job") is to read it in and store it, usually on a hard disk or larger storage medium so that it can be printed or otherwise processed at a more convenient time (for example, when a printer is finished printing its current document).

Check and Cause	Solution
1. Insufficient space of the hard disk in the directory assigned for the basic spool.	1. Delete the unnecessary files to provide more space to start printing job.
2. If the previous printing error not solved.	2. If there are some files with the extension name of ****.jnl, Delete them and Reboot the Windows to restart printing job.
3. When expected to collide with other program.	3. Shut down all other programs except the current one, if possible.
4. When an application program or the printer driver is damaged.	4. Delete the printer driver completely and reinstall it.
5. When some files related to OS are damaged or virus infected.	5 After rebooting the computer, check for viruses, restore the damaged files and reinstall the program to do the printing job.
6. Memory is less than suggested one.	6. Add up enough memory to the PC.

#### How to delete the data in the spool manager.

In the spool manager, the installed drivers and the list of the documents waiting to be printed are shown. Select the document to be deleted and check the delete menu.

If you intend to delete the current document being printed, the data being transferred to the printer will be put out and then the document is removed. Before choosing the document, the menu is still inactive.

Or put the document out of the list and repeat the routine as in the above or finish the spool manager.

# 5. Exploded View & Parts List

You can search for the updated part code through ITSELF Web Site

URL : <http://itself.sec.samsung.co.kr>

- 5-1 Main Exploded View & Parts List ..... page(5-2)
- 5-2 Scanner Ass'y Exploded View & Parts List ..... page(5-5)
- 5-3 ADF UpperAss'y Exploded View & Parts List..... page(5-7)
- 5-4 Scan Lower Ass'y Exploded View & Parts List..... page(5-9)
- 5-5 Side Cover Ass'y Exploded View & Parts List..... page(5-12)
- 5-6 OPE Ass'y Exploded View & Parts List..... page(5-14)
- 5-7 Cassette Ass'y Exploded View & Parts List ..... page(5-16)
- 5-8 Exit Ass'y Exploded View & Parts List..... page(5-18)
- 5-9 Feeder Ass'y Exploded View & Parts List ..... page(5-20)
- 5-10 MP Ass'y Exploded View & Parts List ..... page(5-22)
- 5-11 Base Frame Exploded View & Parts List..... page(5-24)
- 5-12 Pick-up Ass'y Exploded View & Parts List..... page(5-25)
- 5-13 Drive Ass'y Exploded View & Parts List ..... page(5-26)
- 5-14 Main Frame Ass'y Exploded View & Parts List..... page(5-28)
- 5-15 Fuser Ass'y Exploded View & Parts List ..... page(5-30)
- 5-16 SCF Ass'y Exploded View & Parts List ..... page(5-32)
- 5-17 Screw ..... page(5-34)

- Deal drawings and service parts are declared for the items with higher rate of inferiority and replaceable in the level of service description only.
- If inferiority occurs, you can replace the parts by the unit declared in deal drawings and service items.

### Way to observe Part Code & Description

Part code and Description is quoted and controlled by determined standard. Refer to this determined standard, it will help with ordering Part.

- There are two kinds of Part code inscription type.

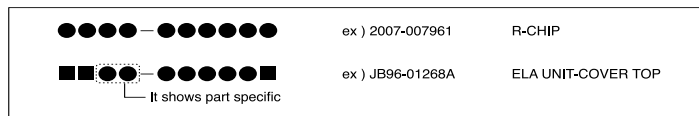

( ● : figure, ■ : character (alphabet) )

**Type 1** : Controlled by Company : It can be commonly used for all kinds of product SEC produce. Mostly, electronics Parts.

**Type 2** : Controlled by Division : It is used on one produce. Mostly, Mostly, mechanical Parts.

- **A/S privately used part** : It is only used for A/S .
- **Ass'y part** : Assembled by more than 2 Parts. If necessary part is not A/S Part, Ass'y part including necessary par can be used. It is shown in the diagram and drawing of SVC manual.
- Ass'y part and A/S privately used Part is distinguished by part Code and Description. The are inscription type 2. It is recognized by Part character and front side of description.

DIVISION	PART CODE	DESCRIPTION
A/S Private	**81_***** (JB81-00039A)	AS-***** (AS-USE)
ASS'Y Part	**75_***** (JB75-00068A)	MEC-***** (MEC-CHUTE)
ASS'Y Part	**92_***** (JB92-01131A)	PBA ***** (PBA MAIN-CONTROLLER)
ASS'Y Part	**97_***** (JB97-01089A)	MEA ***** (MEA UNIT-PULLEY IDLE)

## Appendix information

The following list shows different materials by model.

The material codes mentioned in the manual are subject to change without prior notice.

For the latest exact information, see ITSELF SYSTEM. (<http://itself.sec.samsung.co.kr>)

### •SF-835P/XAA

DESCRIPTION	SEC.CODE
AS-SCANNER ASS'Y	JC81-00780A
ASSY PBA SUB-LIU	JC92-01355A
AS-OPE ASS'Y	JC81-00784A
ELA HOU-OPE ASS'Y	JC96-02300A
PCT-COVER LCD	JC72-00932B

### •SF-835P/XEF

DESCRIPTION	SEC.CODE
AS-SCANNER ASS'Y	JC81-00780D
ASSY PBA SUB-LIU	JC92-01355E
AS-OPE ASS'Y	JC81-00784C
ELA HOU-OPE ASS'Y	JC96-02300C
PCT-COVER LCD	JC72-00932J

### •SF-835P/XEG

DESCRIPTION	SEC.CODE
AS-SCANNER ASS'Y	JC81-00780C
ASSY PBA SUB-LIU	JC92-01355E
AS-OPE ASS'Y	JC81-00784B
ELA HOU-OPE ASS'Y	JC96-02300B
PCT-COVER LCD	JC72-00932H

### •SF-835P/XEU

DESCRIPTION	SEC.CODE
AS-SCANNER ASS'Y	JC81-00780B
ASSY PBA SUB-LIU	JC92-01355G
AS-OPE ASS'Y	JC81-00784A
ELA HOU-OPE ASS'Y	JC96-02300A
PCT-COVER LCD	JC72-00932M

### •SF-835P/XIL (ML-920)

DESCRIPTION	SEC.CODE
AS-SCANNER ASS'Y	JC81-00780E
ASSY PBA SUB-LIU	JC92-01355A
AS-OPE ASS'Y	JC81-00784D
ELA HOU-OPE ASS'Y	JC96-02300F
PCT-COVER LCD	JC72-00932P

### •SF-830/XAA

DESCRIPTION	SEC.CODE
AS-SCANNER ASS'Y	JC81-00780F
ASSY PBA SUB-LIU	JC92-01355A
AS-OPE ASS'Y	JC81-00784A
ELA HOU-OPE ASS'Y	JC96-02300A
PCT-COVER LCD	JC72-00932A

### •SF-830/XEF

DESCRIPTION	SEC.CODE
AS-SCANNER ASS'Y	JC81-00780J
ASSY PBA SUB-LIU	JC92-01355E
AS-OPE ASS'Y	JC81-00784C
ELA HOU-OPE ASS'Y	JC96-02300C
PCT-COVER LCD	JC72-00932F

### •SF-830/XEG

DESCRIPTION	SEC.CODE
AS-SCANNER ASS'Y	JC81-00780H
ASSY PBA SUB-LIU	JC92-01355E
AS-OPE ASS'Y	JC81-00784B
ELA HOU-OPE ASS'Y	JC96-02300B
PCT-COVER LCD	JC72-00932E

### •SF-830/XEU

DESCRIPTION	SEC.CODE
AS-SCANNER ASS'Y	JC81-00780G
ASSY PBA SUB-LIU	JC92-01355G
AS-OPE ASS'Y	JC81-00784A
ELA HOU-OPE ASS'Y	JC96-02300A
PCT-COVER LCD	JC72-00932D

### •SF-830/XIL

DESCRIPTION	SEC.CODE
AS-SCANNER ASS'Y	JC81-00780K
ASSY PBA SUB-LIU	JC92-01355A
AS-OPE ASS'Y	JC81-00784D
ELA HOU-OPE ASS'Y	JC96-02300F
PCT-COVER LCD	JC72-00932L

### 5-1. Main Exploded View & Parts List

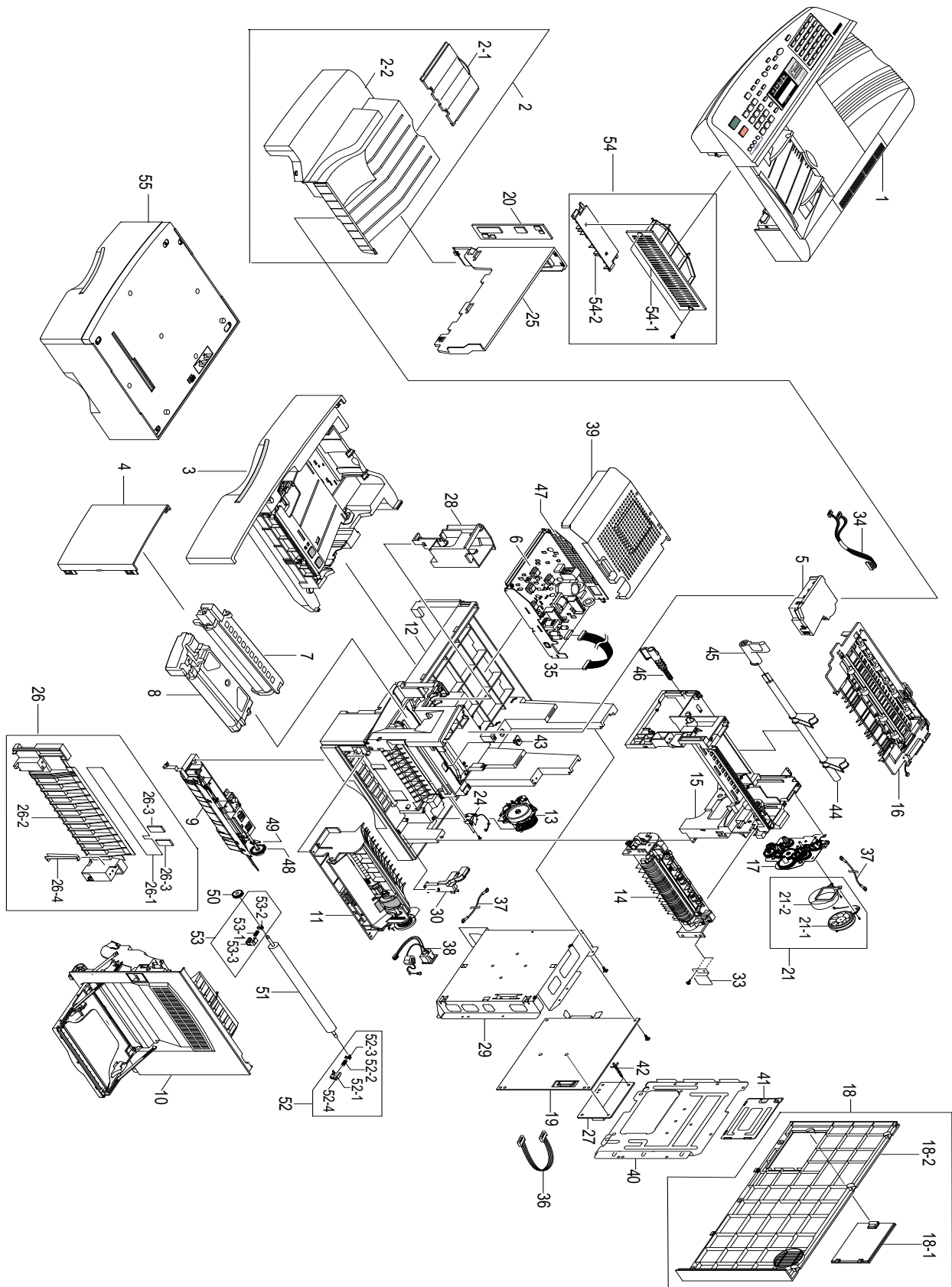

## Main Parts List

( SA. : Service Available )

NO	DESCRIPTION	SEC CODE	Q'TY	SA	REMARK
1	AS-SCANNER ASS'Y	refer to info.	1	O	
2	MEA UNIT-COVER PA EXIT ASS'Y	JC97-01556A	1	O	
2-1	PMO-TRAY EXTENTION MP NE	JC72-00354B	1	O	
2-2	PMO-COVER PAPER EXIT	JC72-00786A	1	O	
3	MEC-UNIT-CASSETTE ASS'Y	JC97-01642A	1	O	LETTER/A4
4	MEA UNIT-COVER FRONT ASS'Y	JC97-01572B	1	O	
5	UNIT-LSU, 600DPI, 12	JC59-00014A	1	O	
6	ELA ETC-SHIELD SMPS COVER(V1)	JC96-02310B	1	O	110V
	ELA ETC-SHIELD SMPS COVER(V2)	JC96-02317A	1	O	220V
7	ELA-OPC UNIT 15K E	JC96-02460A	1	X	
8	ELA-TONER UNIT SET	JC96-02461A	1	X	
9	ELA HOU-PICKUP ASS'Y	JC96-02180A	1	O	
10	ELA HOU-SIDE COVER ASS'Y	JC96-02183A	1	O	
11	ELA HOU-MP ASS'Y	JC96-02182A	1	O	
12	ELA HOU-BASE FRAME ASS'Y	JC96-02414A	1	O	
13	MEC-FEED ASS'Y	JC75-00143A	1	O	
14	ELA HOU-FUSER(110V)ASS'Y	JC96-02194A	1	O	110V
	ELA HOU-FUSER(220V)ASS'Y	JC96-02178A	1	O	220V
15	ELA HOU-FRAME MAIN ASS'Y	JC96-02184A	1	O	
16	MEC-UNIT EXIT ASS'Y	JC97-01625A	1	O	
17	ELA HOU-DRIVE ASS'Y	JC96-02181A	1	O	
18	MEA UNIT-COVER REAR ASS'Y	JC97-01557A	1	O	
18-1	PMO-COVER SIMM,XR X	JC72-41224B	1	O	
18-2	PMO-COVER REAR	JC72-00788A	1	O	
19	ASS'Y PBA MAIN-MAIN B'D	JC92-01375A	1	O	SF-835P
	ASS'Y PBA MAIN-MAIN B'D	JC92-01375B	1	O	SF-830
20	PMO-CONNECT PANER MFP	JC72-00782A	1	O	SF-835P
	PMO-CONNECT PANER MFP	JC72-00782C	1	O	SF-830
21	ELA HOU-DUCT FAN	JC96-02311A	1	O	
21-1	FAN-DC	JC31-00012A	1	O	
21-2	PMO-DUCT FAN	JC72-00807A	1	O	
24	SOLENOID-PICK UP	JC33-00007A	1	O	
25	PMO-COVER EXIT REAR	JC72-00790A	1	O	
26	MEA UNIT GUIDE CST PA ASS'Y	JC97-01624A	1	O	
26-1	PMO-SHEET GUIDE PAPER	JC72-00836A	1	X	
26-2	PMO-GUIDE CASSETTE RAIL	JC72-00791A	1	X	
26-3	SHEET FEED	JC72-00078A	2	X	
26-4	IPR-GUIDE CST PAPER	JC70-00244A	1	X	
27	ASSY PBA SUB-LIU	refer to info.	1	O	
28	PMO-DUMMY BASE FRAME	JC72-00789A	1	O	
29	IPR-SHIELD MAIN LOWER	JC70-00245A	1	O	
30	PMO-COVER FEED AY	JC72-00801A	1	O	
31	PMO-COVER BRKT MOTER	JC72-00834A	1	O	
32	PMO-GUIDE PAPER OUT	JC72-00835A	1	O	
33	SHEET-CONNECTOR	JC63-00072A	1	X	

O : Service available X : Service not available

**Main Parts List (Cont.)**

( SA. : Service Available )

NO	DESCRIPTION	SEC CODE	Q'TY	SA	REMARK
34	CBF HARNESS-LSU	JC39-00163A	1	O	
35	CBF HARNESS-POWER+HVPS	JC39-00162A	1	O	
36	CBF HARNESS-LIU	JB39-00104A	1	O	
37	CBF HARNESS-LIU GND	JB39-00103A	1	O	
38	CBF HARNESS-INLET	JC39-00172A	1	O	
39	IPR-SHIELD SMPS UPPER	JC70-00248A	1	O	
40	IPR-SHIELD MAIN UPPER	JC70-00246A	1	O	
41	IPR-SHIELD SIMM	JC70-10234A	1	O	
42	SUPPORTER	6103-001048	2	O	
43	PMO-WINDOW SENSOR DEVE	JC72-00792A	1	O	
44	PMO-CAM JAM REMOVE	JC72-00799A	1	O	
45	PMO-LOCKER DEVE	JC72-00805A	1	O	
46	PMO-LEVER JAM REMOVE	JC72-00804A	1	O	
47	IPR-SHIELD SMPS LOWER	JC70-00247A	1	O	
48	GEAR-PICK-UP	JC66-00335A	1	O	
49	PMO-BEARING SHAFT	JC72-41191A	1	O	
50	GEAR-TRANSFER	JC66-40947A	1	O	
51	TRANSFER MEC-ROLLER	JC75-00148A	1	O	
52	MEA UNIT-HOLDER GEAR ASS'Y	JC97-01573A	1	O	
52-1	SPRING ETC-PLATE TR	*	1	X	
52-2	SPRING ETC-TR_L	*	1	X	
52-3	PMO-BUSH	*	1	X	
52-4	PMO-HOLDER GND TR	*	1	X	
53	MEA UNIT-HOLDER GND ASS'Y	JC97-01574A	1	O	
53-1	SPRING ETC-TR_R	*	1	X	
53-2	PMO-BUSH	*	1	X	
53-3	PMO-HOLDER GEAR TR	*	1	X	
54	MEA ETC-COVER REAR ASS'Y	JC97-01620A	1	O	
54-1	PMO-GUIDE-EXIT-OPEN	JC72-00939A	1	O	
54-2	PMO-COVER REAR	JC72-00915A	1	O	
55	ELA UNIT-CSF ASS'Y(ZEUS)	*	1	X	OPTIONAL

O : Service available X : Service not available

## 5-2. Scanner Ass'y Exploded View & Parts List

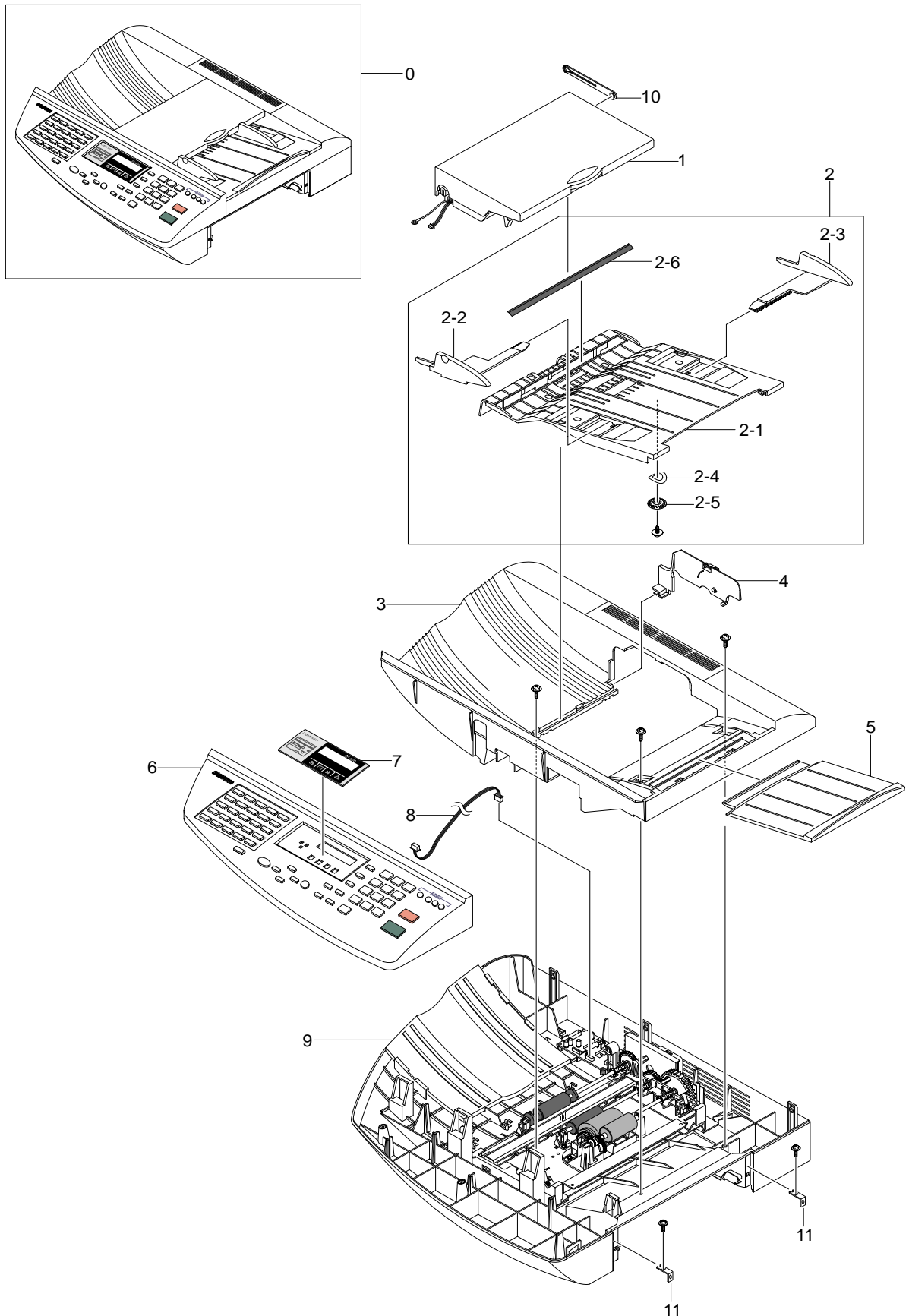

**Scanner Ass'y Parts List**

( SA. : Service Available )

NO	DESCRIPTION	SEC CODE	Q'TY	SA	REMARK
0	AS-SCANNER ASS'Y	refer to info.	1	O	
1	ELA HOU-ADF UPPER ASS'Y	JC96-02301A	1	O	
2	MEA HOU-GUIDE LOWER ASS'Y	JC97-01627A	1	O	
2-1	PMO-GUIDE LOWER	JC72-00900A	1	O	
2-2	PMO-GUIDE DOC R	JC72-00902A	1	O	
2-3	PMO-GUIDE DOC L	JC72-00901A	1	O	
2-4	IPR-WASHER SPRING CU	JF70-10616A	1	O	
2-5	GEAR-PINION	JG66-40003A	1	O	
2-6	PPR-FILM CIS	JC72-00931A	1	O	
3	PMO-HOUSING UPPER ADF	JC72-00894A	1	O	
4	PMO-COVER GEAR	JC72-00914A	1	O	
5	PMO-TRAY INPUT DOC	JC72-00897A	1	O	
6	AS-OPE ASS'Y	refer to info.	1	O	
7	PCT-COVER LCD	refer to info.	1	O	
8	CBF HARNESS-OPE	JC39-00167A	1	O	
9	AS-HOU LOWER ASS'Y	JC81-00785A	1	O	
10	PMO-TRAY LINK,MP	JC72-00857A	1	O	
11	IPR B/K JOINT COVER	JC70-00297A	2	O	
S6	SCREW-TAPTITE	6003-000196	14	O	

O : Service available X : Service not available

### 5-3. ADF Upper Ass'y Exploded View & Parts List

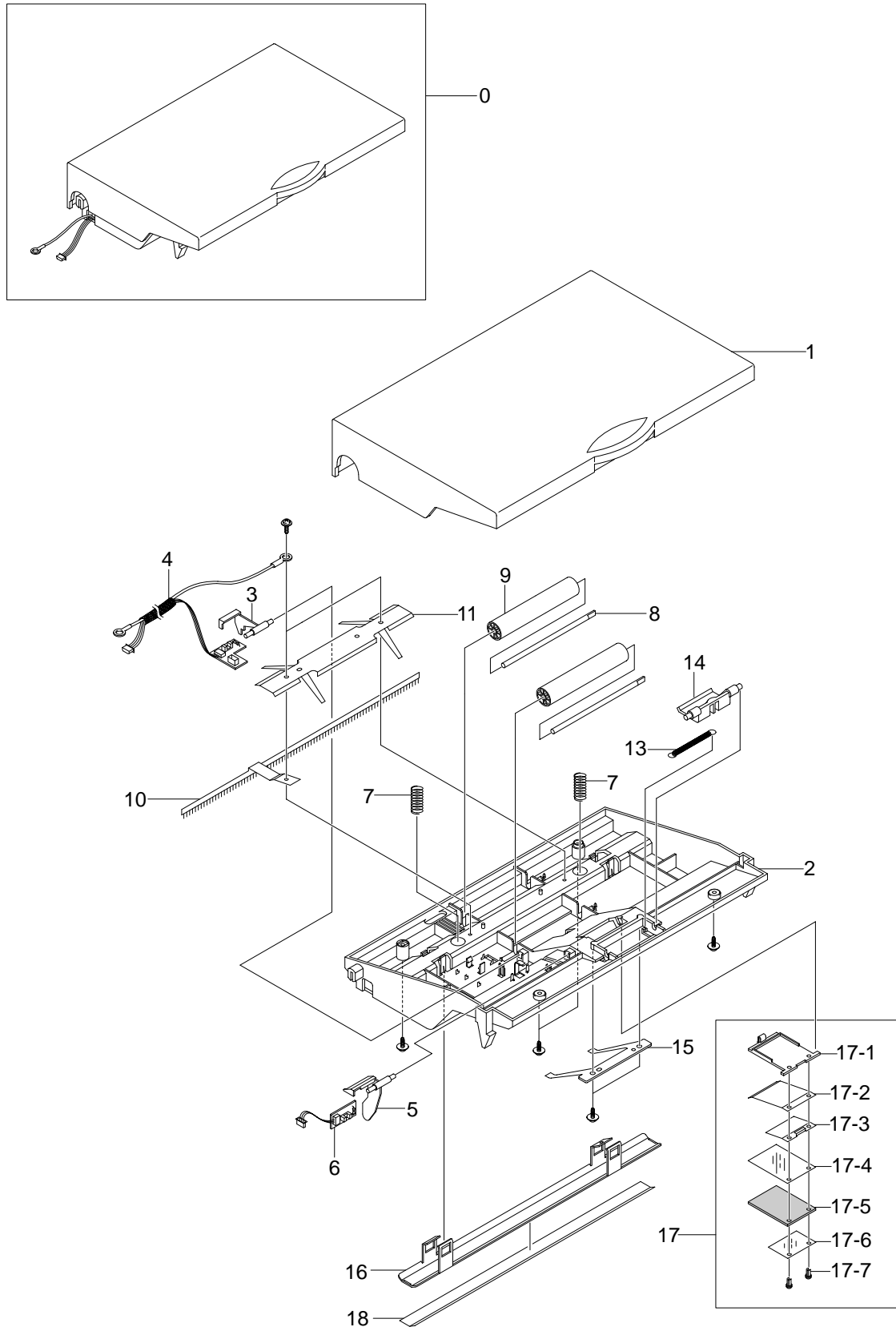

**ADF Upper Ass'y Parts List**

( SA. : Service Available )

NO	DESCRIPTION	SEC CODE	Q'TY	SA	REMARK
0	ELA HOU-ADF UPPER ASS'Y	JC96-02301A	1	O	
1	PMO-COVER TOP	JC72-00898A	1	O	
2	PMO-GUIDE UPPER	JC72-00899A	1	O	
3	PMO-ACTUATOR SCAN	JC72-00904A	1	O	
4	CBF HARNESS-ADF POS SCAN ASS'Y	JC39-00227A	1	O	
5	PMO-ACTUATOR DOC	JC72-00903A	1	O	
6	PBA SUB-ADF DET SEN	JC92-01366A	1	O	
7	SPRING ETC-PICK UP MP	JC61-00041A	2	O	
8	ICT-SHAFT IDLE ROLLER	JC70-00295A	2	O	
9	MEC IDLE ROLLER	JC75-00160A	2	O	
10	MEC-BRUSH ANTISTATIC	JC75-00095A	1	O	
11	IPR-SPRING IDLE ROLLER	JC70-00287A	1	O	
12	IPR-GROUND EXTENSION	JC70-00294A	1	O	
13	SPRING ETC-PAPER OUT	JB61-00070A	1	O	
14	PMO-HOLDER PICK UP	JC72-00926A	1	O	
15	PMO-SPRING ADF SET	JC72-00922A	1	O	
16	IPR-BRKT WHITE BAR	JC70-00225A	1	O	
17	MEA HOU-PRESSER ADF ASSY	JC97-01664A	1	O	
17-1	PMO-HOLDER ADF	*	1	X	
17-2	IPR-SPRING ADF1	*	1	X	
17-3	IPR-SPRING ADF2	*	1	X	
17-4	PPR-FILM ADF2	*	1	X	
17-5	SILICON/RUBBER-PAD ADF	*	1	X	
17-6	PPR-FILM ADF1	*	1	X	
17-7	RIVET-SNAP	*	2	X	
18	PPR-WHITE BAR SHEET	JC72-00752A	1	O	

O : Service available X : Service not available

### 5-4. Scan Lower Ass'y Exploded View & Parts List

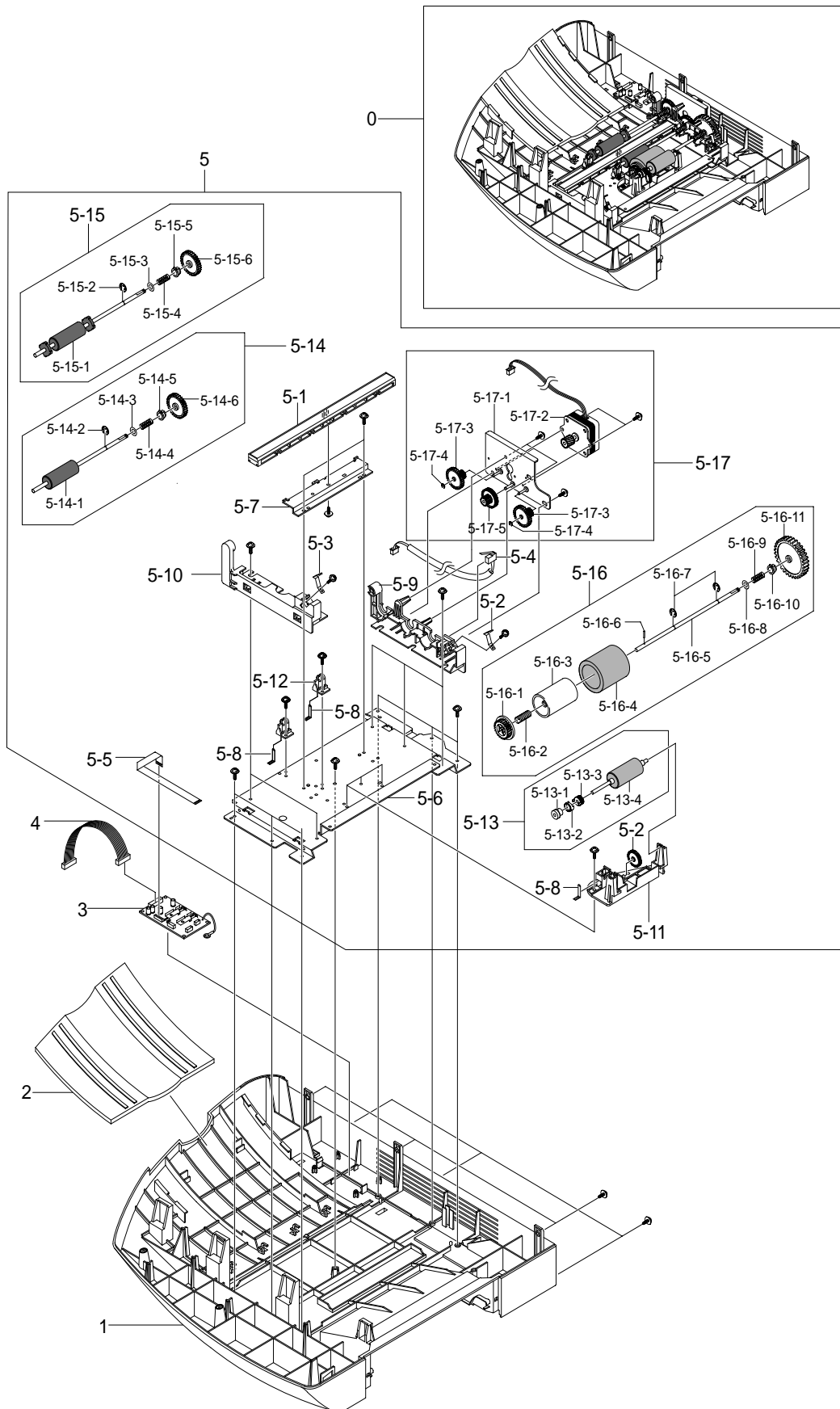

## Scan Lower Ass'y Parts List

( SA. : Service Available )

NO	DESCRIPTION	SEC CODE	Q'TY	SA	REMARK
0	AS-HOU LOWER ASSY	JC81-00785A	1	O	
1	PMO-HOUSING LOWER ADF	JC72-00895A	1	O	
2	PMO-TRAY EXIT DOC	JC72-00896A	1	O	
3	AS-SCAN PBA	JC81-00786A	1	O	
4	CBF HARNESS-MAIN-ENGINE	JC39-00030A	1	O	
5	AS-ADF LOWER ASSY	JC81-00787A	1	O	
5-1	CONTACT IMAGE SENSOR	0609-001162	1	O	
5-2	GEAR-PICK UP IDEL 38	JB66-00102A	1	O	
5-3	IPR-LOKER TX	JB70-10958A	2	O	
5-4	CBF HARNESS-COVER SW	JC39-00142A	1	O	
5-5	CBF FLAT CBL-FFC	JC39-00191A	1	O	
5-6	IPR-BRKT BASE	JC70-00289A	1	O	
5-7	IPR-BRKT CIS	JC70-00290A	1	O	
5-8	IPR-GROUND SHAFT	JC70-00293A	3	O	
5-9	PMO-FRAME SIDE L	JC72-00907A	1	O	
5-10	PMO-FRAME SIDE R	JC72-00908A	1	O	
5-11	PMO-BRACKET PICK UP	JC72-00909A	1	O	
5-12	PMO-HOLDER SHAFT	JC72-00913A	2	O	
5-13	MEA HOU-PICK UP ASS'Y	JC97-01661A	1	O	
5-13-1	PMO-BUSHING PICK UP	*	1	X	
5-13-2	PMO-PICK UP CLUTCH SUB	*	1	X	
5-13-3	GEAR-PICK UP	*	1	X	
5-13-4	MEC-ROLLER PICK UP	*	1	X	
5-14	MEA HOU-ROLLER SCAN ASS'Y	JC97-01658A	1	O	
5-14-1	MEC-ROLLER SCAN	*	1	X	
5-14-2	RING-E	*	1	X	
5-14-3	WASHER-PLAIN	*	1	X	
5-14-4	SPRING ETC-SHAFT	*	1	X	
5-14-5	PMO-BUSHING SHAFT	*	1	X	
5-14-6	GEAR-AGITATOR_1	*	1	X	
5-15	MEA ETC-ROLLER EXIT ASS'Y	JC97-01659A	1	O	
5-15-1	MEC-ROLLER EXIT	*	1	X	
5-15-2	RING-E	*	1	X	
5-15-3	WASHER-PLAIN	*	1	X	
5-15-4	SPRING ETC-SHAFT	*	1	X	
5-15-5	PMO-BUSHING SHAFT	*	1	X	
5-15-6	GEAR-AGITATOR_1	*	1	X	
5-16	MEA HOU-ROLLER ADF ASS'Y	JC97-01613A	1	O	
5-16-1	GEAR-ADF ROLL	*	1	X	
5-16-2	SPRING ETC-CLUTCH	*	1	X	
5-16-3	PMO-SLEEVE ADF	*	1	X	
5-16-4	MEC-ROLLER ADF	*	1	X	
5-16-5	ICT-SHAFT ADF	*	1	X	
5-16-6	ICT-PIN ADF	*	1	X	

NO	DESCRIPTION	SEC CODE	Q'TY	SA	REMARK
5-16-7	RING-E	*	2	X	
5-16-8	WASHER-PLAIN	*	1	X	
5-16-9	SPRING ETC-SHAFT	*	1	X	
5-16-10	PMO-BUSHING SHAFT	*	1	X	
5-16-11	GEAR-ADF	JC66-00363A	1	O	
5-17	AS-MOTOR ASSY	JC81-00788A	1	O	
5-17-1	IPR-BRKT GEAR	*	1	X	
5-17-2	MOTOR-STEPPING HELICAL	*	1	X	
5-17-3	GEAR-REDUCTION 45/19	*	2	X	
5-17-4	RING-C	*	2	X	
5-17-5	GEAR-RDCN 4316	*	1	X	

O : Service available X : Service not available

### 5-5. OPE Ass'y Exploded View & Parts List

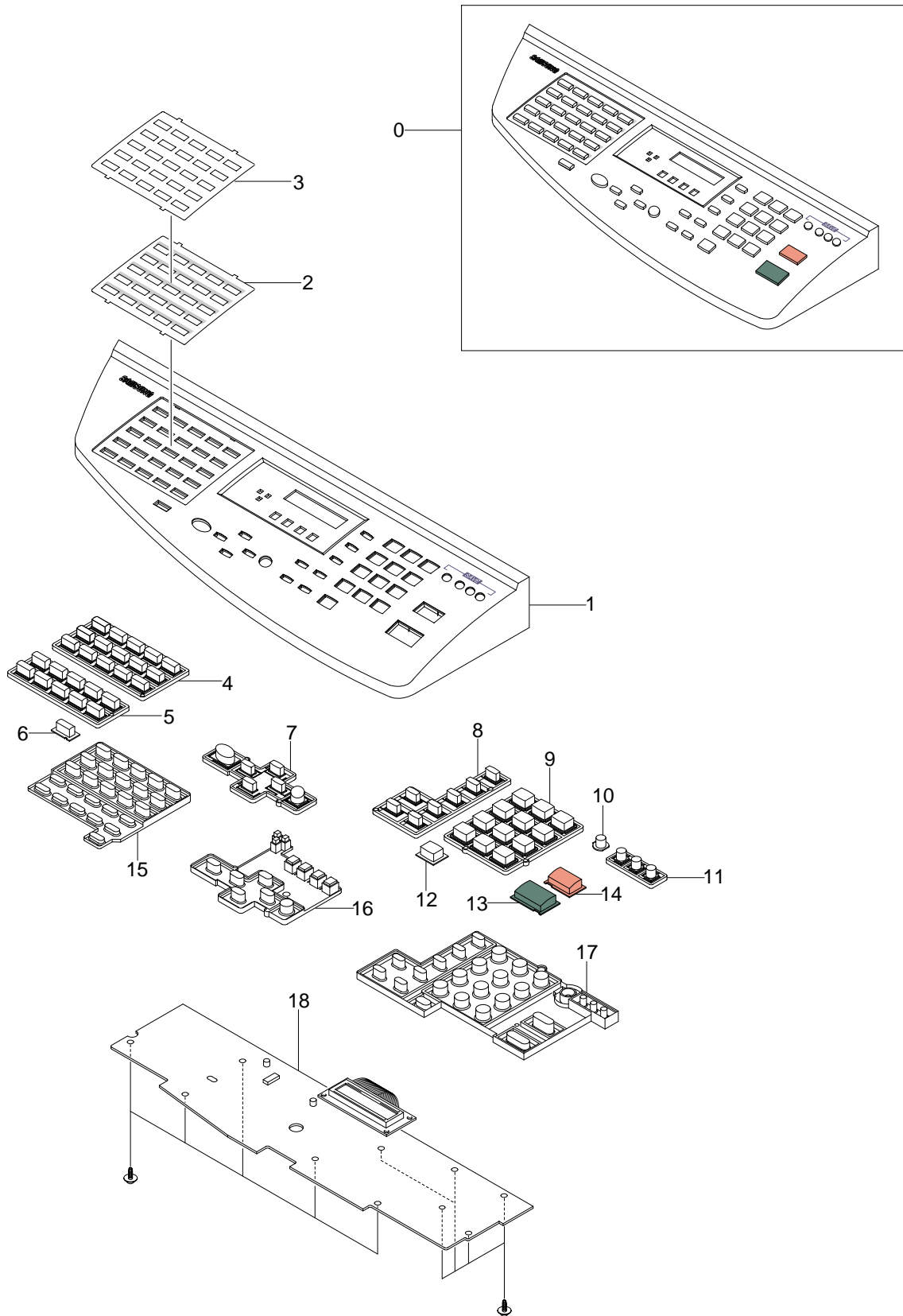

**OPE Ass'y Parts List**

( SA. : Service Available )

NO	DESCRIPTION	SEC CODE	Q'TY	SA	REMARK
0	AS-OPE ASS'Y	refer to info.	1	O	
1	PMO-OPE COVER	JC72-00891A	1	O	
2	PCT-PAPER MEMORY	JC72-00934A	1	O	
3	PCT-CARD MEMORY	JC72-00933A	1	O	
4	PMO-KEY MEMORY(A)	JC72-00888A	1	O	
5	PMO-KEY MEMORY(B)	JC72-00889A	1	O	
6	PMO-KEY SHIFT	JC72-00893A	1	O	
7	PMO-KEY SCROLL	JC72-00866A	1	O	
8	PMO-KEY FUNCTION	JC72-00890A	1	O	
9	PMO-KEY TEL	JC72-00865A	1	O	
10	PMO-KEY SAVE(T)	JC72-00923A	1	O	
11	PMO-KEY SAVE	JC72-00892A	1	O	
12	PMO-KEY OHD	JC72-00864A	1	O	
13	PMO-KEY START	JC72-00868A	1	O	
14	PMO-KEY STOP	JC72-00869A	1	O	
15	RMO-KEY RUBBER MEMORY	JC73-00111A	1	O	
16	RMO-KEY RUBBER NAVI	JC73-00110A	1	O	
17	RMO-KEY RUBBER TEL	JC73-00109A	1	O	
18	AS-OPE PBA	JC81-00789A	1	O	
S	SCREW-TAPPING	6002-000319	9	O	

O : Service available X : Service not available

## 5-6. Side Cover Ass'y Exploded View & Parts List

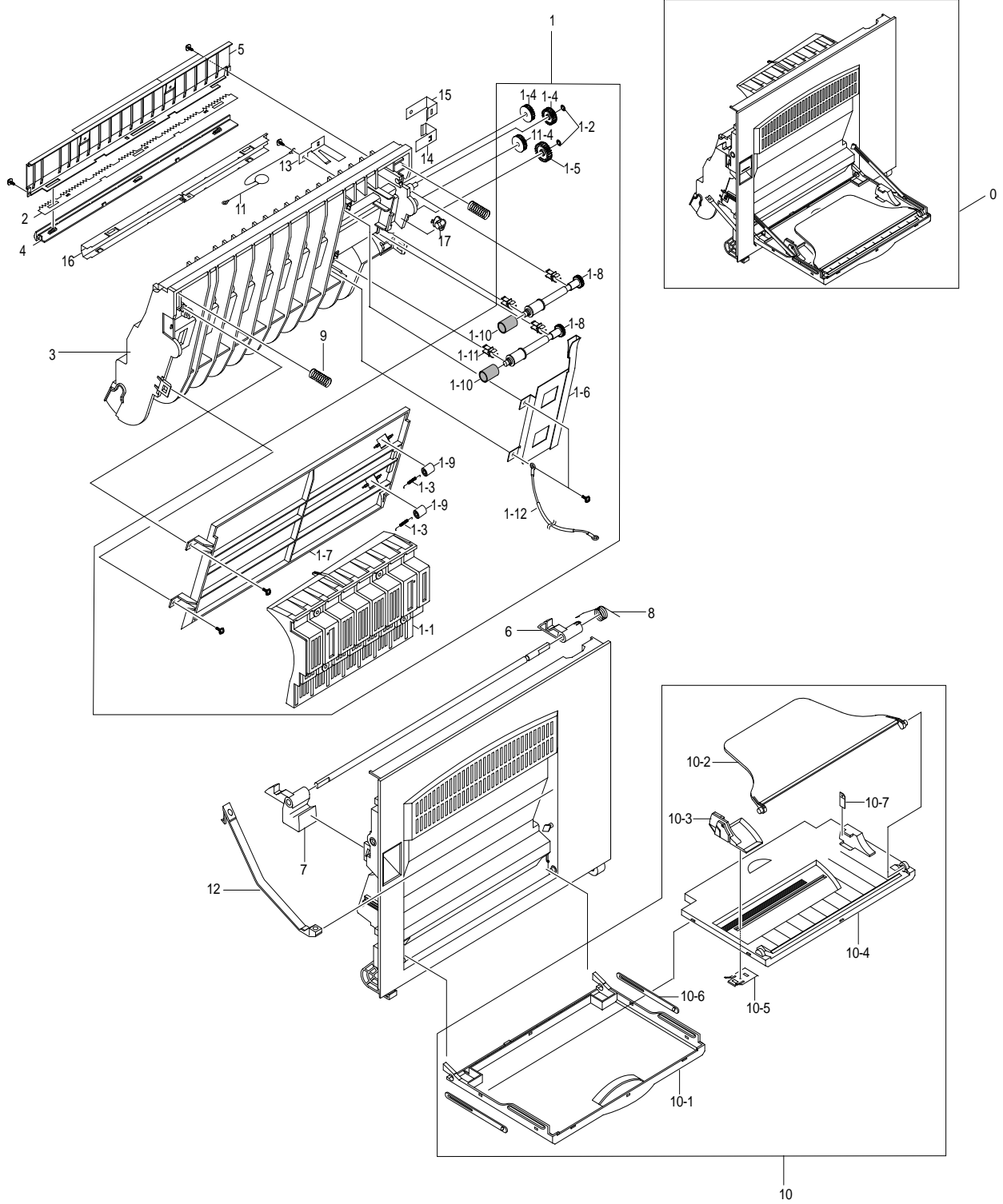

## Side Cover Ass'y Parts List

( SA. : Service Available )

NO	DESCRIPTION	SEC CODE	Q'TY	SA	REMARK
0	ELA HOU-SIDE COVER ASS'Y	JC96-02183A	1	O	
1	MEA UNIT-DUPLEX ASS'Y	JC97-01578A	1	O	
1-1	PMO-GUIDE DP SIDE	*	1	X	
1-2	RING-CS	*	2	X	
1-3	SPRING-FUSER EXIT	*	2	X	
1-4	GEAR-DUP IDLER 17	*	3	X	
1-5	GEAR-MP/DUP DRV	*	1	X	
1-6	IPR-BRKT G DUP	*	1	X	
1-7	PMO-GP LOWER DP	*	1	X	
1-8	PMO-SHAFT DUP DRIVER	*	2	X	
1-9	PMO-ROLLER_EXIT	*	2	X	
1-10	RPR-RUBBER EXIT	*	2	X	
1-11	PMO-BUSHING TX(B4)	*	4	X	
1-12	CBF HARNESS-SCAN GND	*	1	X	
2	IPR-PLATE SAW	JC70-10232A	1	O	
3	PMO-FEED FRAME	JC72-00731A	1	O	
4	PMO-HOLDER SAW	JC72-41213A	1	O	
5	IPR-BRACKET GUIDE A	JC70-00229A	1	O	
6	PMO-LOCKER SIDE R	JC72-00763A	1	O	
7	PMO-LOCKER OPEN	JC72-00762A	1	O	
8	SPRING-LOCKER TORSION	JC61-00479A	1	O	
9	SPRING-FEED	JC61-00478A	2	O	
10	MEC UNIT-TRAY ASS'Y	JC97-01577A	1	O	
10-1	PMO-TRAY CASE, MP	*	1	X	
10-2	PMO-TRAY-EXT, MP	*	1	X	
10-3	PMO-SIDE GUIDE, MP	*	1	X	
10-4	PMO-TRAY COVER, MP	*	1	X	
10-5	IPR-GUIDE LATCH	*	1	X	
10-6	PMO-TRAY LINK,MP	*	1	X	
10-7	LABEL(R)-HEIGHT,MP	*	1	X	
11	CBF HARNESS-OPE GND	*	1	X	
12	PMO-TIE STOPPER	JC72-00766A	2	O	
13	IPR-BRKT GROUND B	JC70-00230A	1	O	
14	IPR-BRKT GROUND TR	JC70-00231A	1	O	
15	IPR-BRKT GROUND A	JC70-00232A	1	O	
16	IPR-BRACKET GUIDE B	JC70-00234A	1	O	
17	PMO-BUSHING FEED	JC72-00730A	1	O	

O : Service available X : Service not available

### 5-7. Cassette Ass'y Exploded View & Parts List

---

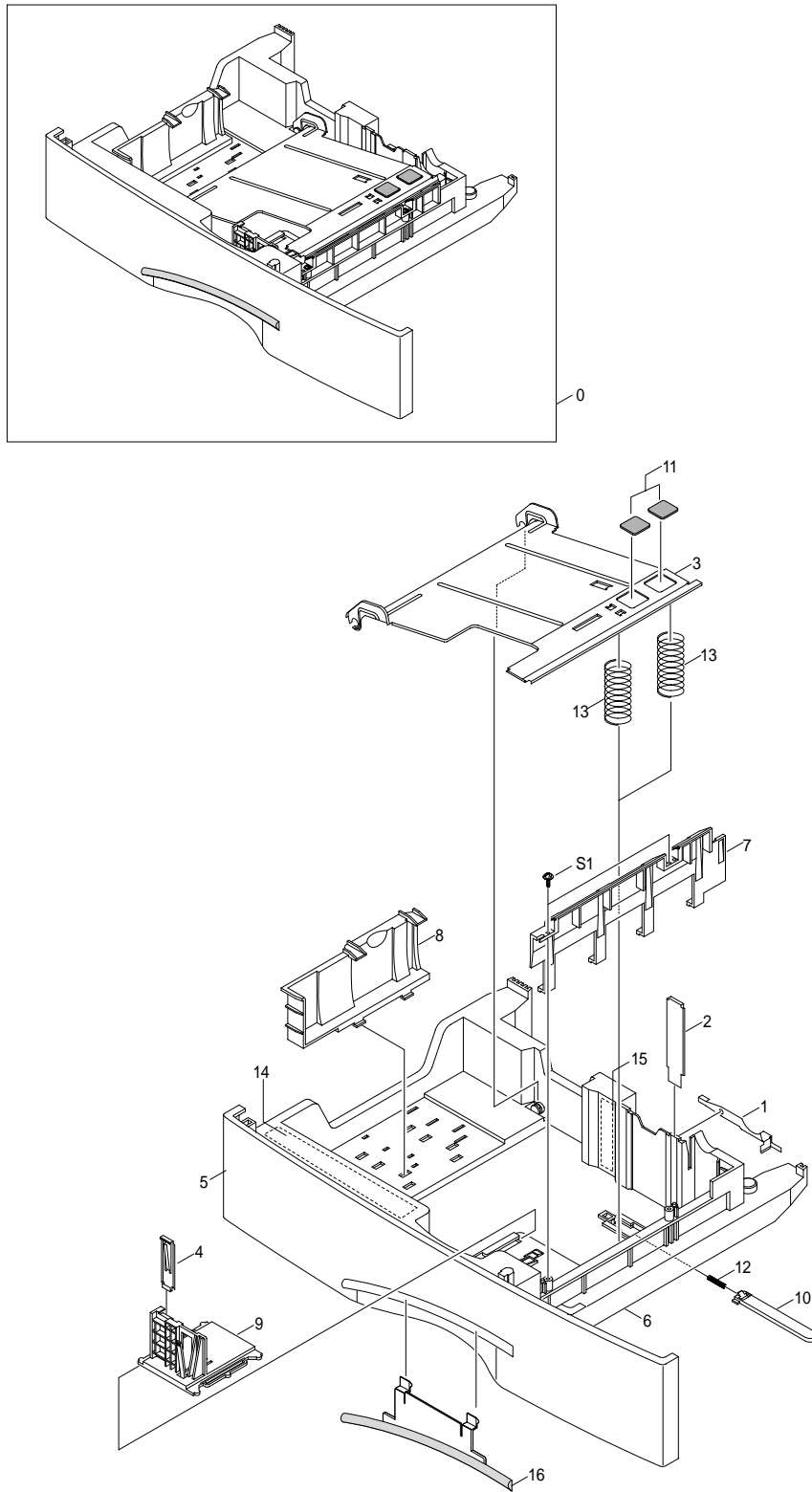

**Cassette Ass'y Parts List**

( SA. : Service Available )

NO	DESCRIPTION	SEC CODE	Q'TY	SA	REMARK
0	MEA UNIT-CASSETTE ASS'Y	JC97-01642A	1	O	
1	IPR-FINGER	*	1	X	
2	IPR-GUIDE PLT PAPER	*	1	X	
3	IPR-PLATE K/UP	*	1	X	
4	IPR-SPR PLT G/SIDE	JC70-10929A	1	O	
5	PMO-COVER CASSETTE	*	1	X	
6	PMO-FRAME CASSETTE	*	1	X	
7	PMO-GUIDE FRONT CST	*	1	X	
8	PMO-GUIDE REAR	JC72-00717A	1	O	
9	PMO-GUIDE/SIDE CST	JC72-40967D	1	O	
10	PMO-LOCKER PLATE	JC72-41210A	1	O	
11	PRP-PAD CST	JC73-10910A	2	O	
12	SPRING ETC-LOCKER PLATE	JG61-70531A	1	O	
13	SPRING ETC-PLATE K/UP	JC61-00455A	2	O	
14	LABEL(R)-INSTRUCTION CST	*	1	X	
15	LABEL(R)-HEIGHT CST	*	1	X	
16	PMO-IMPACT CASSETTE	*	1	X	

O : Service available X : Service not available

### 5-8. Exit Ass'y Exploded View & Parts List

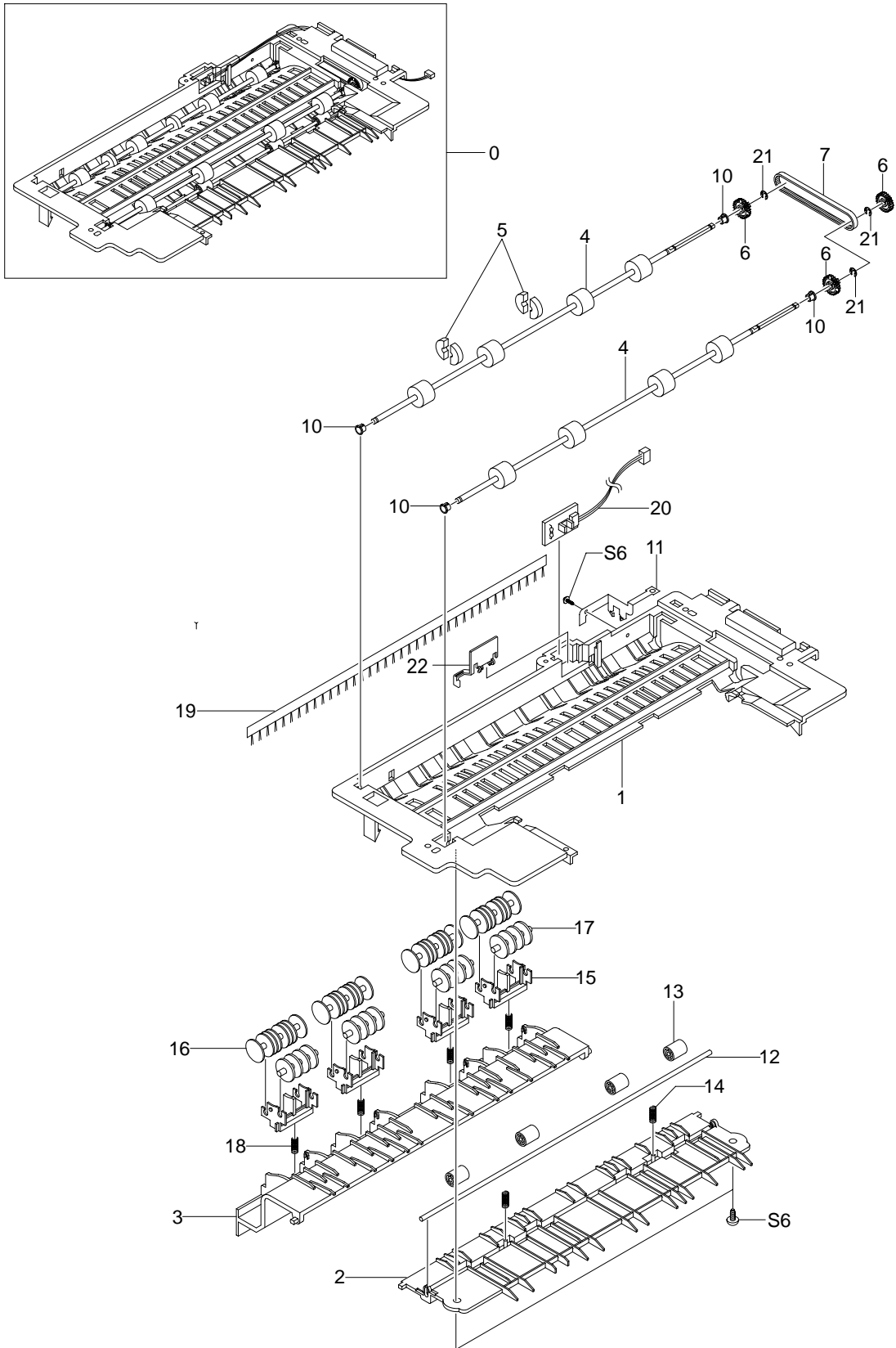

**Exit Ass'y Parts List**

( SA. : Service Available )

NO	DESCRIPTION	SEC CODE	Q'TY	SA	REMARK
0	MEC UNIT-EXIT ASS'Y	JC97-01625A	1	O	
1	PMO-GUIDE-EXIT UPPER ZE	*	1	X	
2	PMO-GUIDE-EXIT LOWER	*	1	X	
3	PMO-GUIDE-JAM REMOVE	*	1	X	
4	MEC-ROLLER EXIT DRV	JC75-00127A	2	O	
5	PMO-ROLLER DECURL	JC72-00833A	4	O	
6	PMO-PULLEY DUPLEX	*	2	X	
7	BELT-TIMING GEAR	*	1	X	
8	GEAR-DUPLEX	*	1	X	
9	PMO-BEARING LARGE DP	*	3	X	
10	PMO-BEARING LARGE DP	JC72-40978A	1	O	
11	IPR-GROUND-EXIT	*	1	X	
12	ICT-SHAFT-EXIT LOWER ID	*	1	X	
13	PMO-ROLLER_EXIT	*	4	X	
14	SPRING-EXIT ROLL FD	*	2	X	
15	PMO-HOLDER EXIT ROLL	*	4	X	
16	PMO-ROLLER FD F	*	4	X	
17	PMO-ROLLER FD R	*	4	X	
18	SPRING ETC-EXIT LOWER IDLE	*	4	X	
19	MEC- BRUSH ANTISTATIC	JC75-00095A	1	O	
20	PBA SUB-BIN-FULL SENSOR	JC92-01400A	1	O	
21	RING-C	*	3	X	
22	PMO-LEVER STACKING	JC72-00709A	1	O	

O : Service available X : Service not available

### 5-9. Feeder Ass'y Exploded View & Parts List

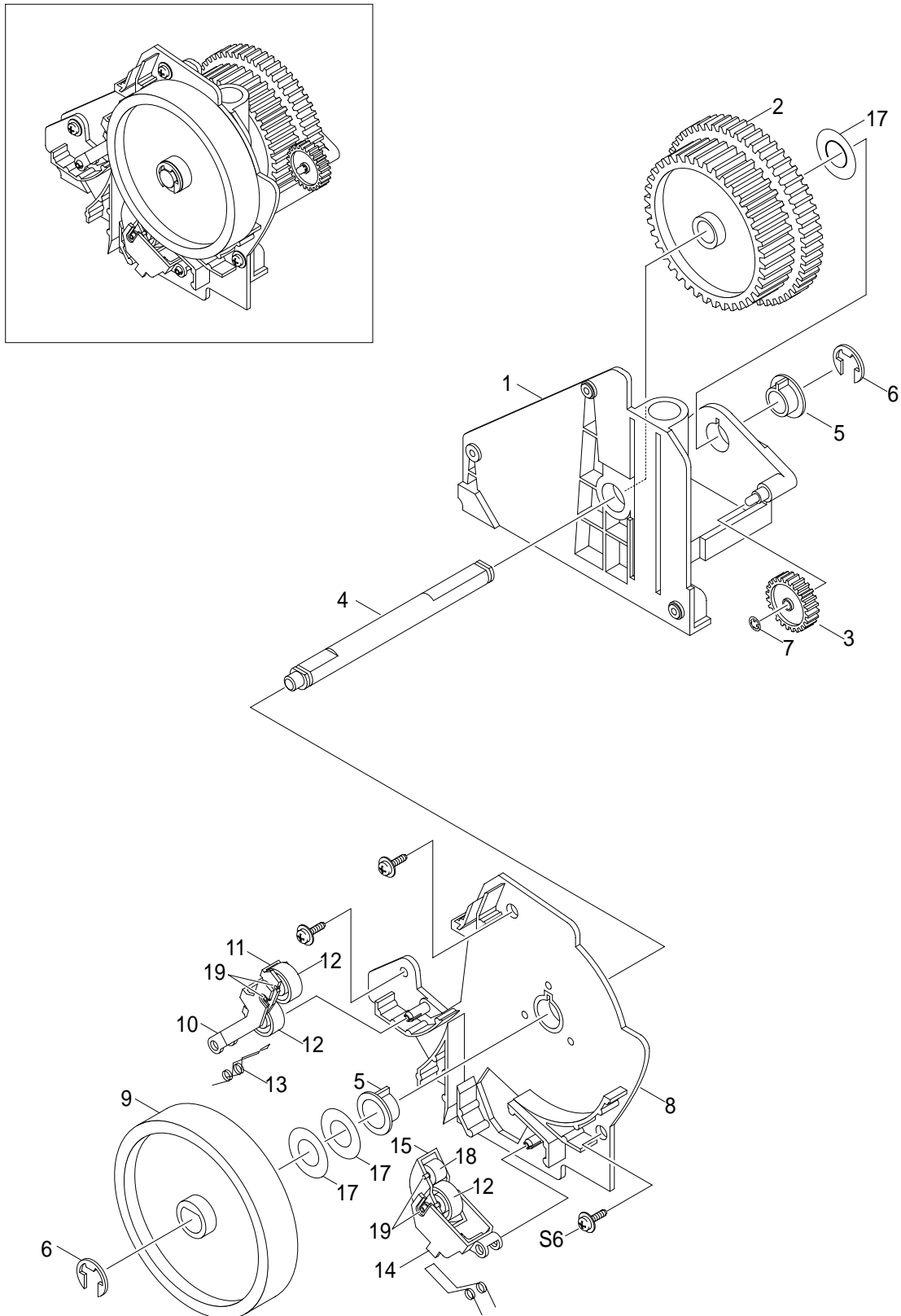

**Feeder Ass'y Parts List**

( SA. : Service Available )

NO	DESCRIPTION	SEC CODE	Q'TY	SA	REMARK
0	MEC-FEED ASS'Y	JC75-00143A	1	O	
1	PMO-FRAME FEED	*	1	X	
2	GEAR-FEED	*	1	X	
3	GEAR-MP/DUP DRV	*	1	X	
4	ICT-SHAFT FEED	*	1	X	
5	BEARING-PICKUP	*	2	X	
6	RING-E	*	2	X	
7	RING-CS	*	1	X	
8	PMO-BRKT FEED	*	1	X	
9	PMO-ROLLER FEED	JC72-00727A	1	O	
10	PMO-HOLDER PINCH C	*	1	X	
11	PMO-HOLDER PINCH SUB	*	1	X	
12	PMO-ROLLER FEED L	*	3	X	
13	SPRING-FEED CAST	*	1	X	
14	PMO-HOLDER PINCH M	*	1	X	
15	PMO-SUB HOLDER FEED	*	1	X	
16	SPRING ETC-FEED MP	*	1	X	
17	WASHER-PLAIN	*	3	X	
18	PMO-ROLLER FEED S	*	1	X	
19	IPR-SHAFT FEED IDLER	*	4	X	

O : Service available X : Service not available

### 5-10. MP Ass'y Exploded View & Parts List

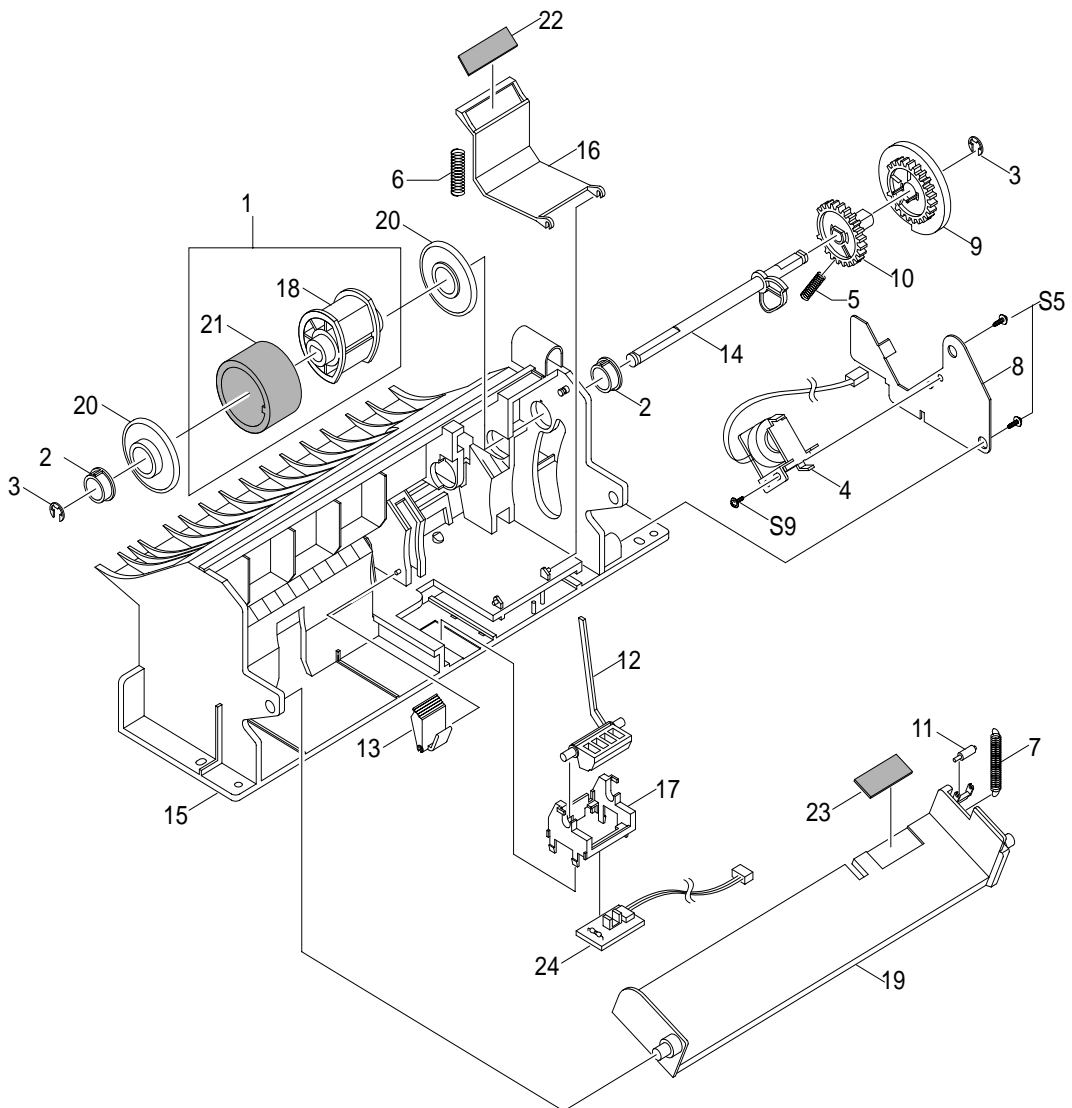
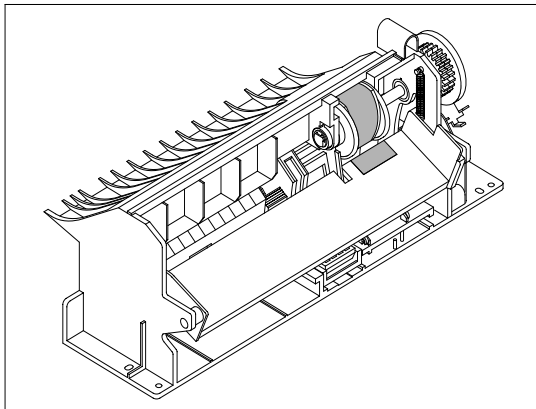

## MP Ass'y Parts List

( SA. : Service Available )

NO	DESCRIPTION	SEC CODE	Q'TY	SA	REMARK
0	ELA HOU-MP ASS'Y	JC96-02182A	1	O	
1	A/S-PICK UP, MP AS(FRV)	JC81-00427A	1	O	
2	PMO-BUSHING PICK UP,MP	JC72-41364A	2	O	
3	RING-E	6044-000125	2	O	
4	SOLENOIDE,MP	JC33-00006A	1	O	
5	SPRING ETC-CAM MP	JC61-00003A	1	O	
6	SPRING ETC-PICK UP,MP	*	1	X	
7	SPRING ETC-KNOCKUP,MP	JC61-00483A	1	O	
8	IPR-BRACKET SOLENOIDE	*	1	X	
9	PMO-HOLDER CAM MPF	*	1	X	
10	PMO-GEAR P/U MPF	*	1	X	
11	PMO-ROLLER CAM.MP	*	1	X	
12	PMO-ACTUATOR,MP	JC72-00767A	1	O	
13	PMO-ADJUSTER,MP	JC72-00768A	1	O	
14	PMO-CAM PICK UP,MP	JC72-00769A	1	O	
15	PMO-FRAME,MP	*	1	X	
16	PMO-HOLDER PAD,MP	JC72-00771A	1	O	
17	PMO-HOLDER SENSOR,MP	JC72-00772A	1	O	
18	PMO-HOUSING PICK UP,MP	*	1	X	
19	PMO-PLATE KNOCK UP,MP	*	1	X	
20	PMO-IDLE PICK UP,MP	JC72-41027A	2	O	
21	RPR-RUBBER PICK UP,MP	*	1	X	
22	RPR-RCT-PAD-PICKUP,MP	JC73-00090A	1	O	
23	RPR-PAD KNOCK UP,MP	JC73-10906A	1	O	
24	PBA SUB-MP SEN	JC92-01362A	1	O	

O : Service available X : Service not available

### 5-11. Base Frame Exploded View & Parts List

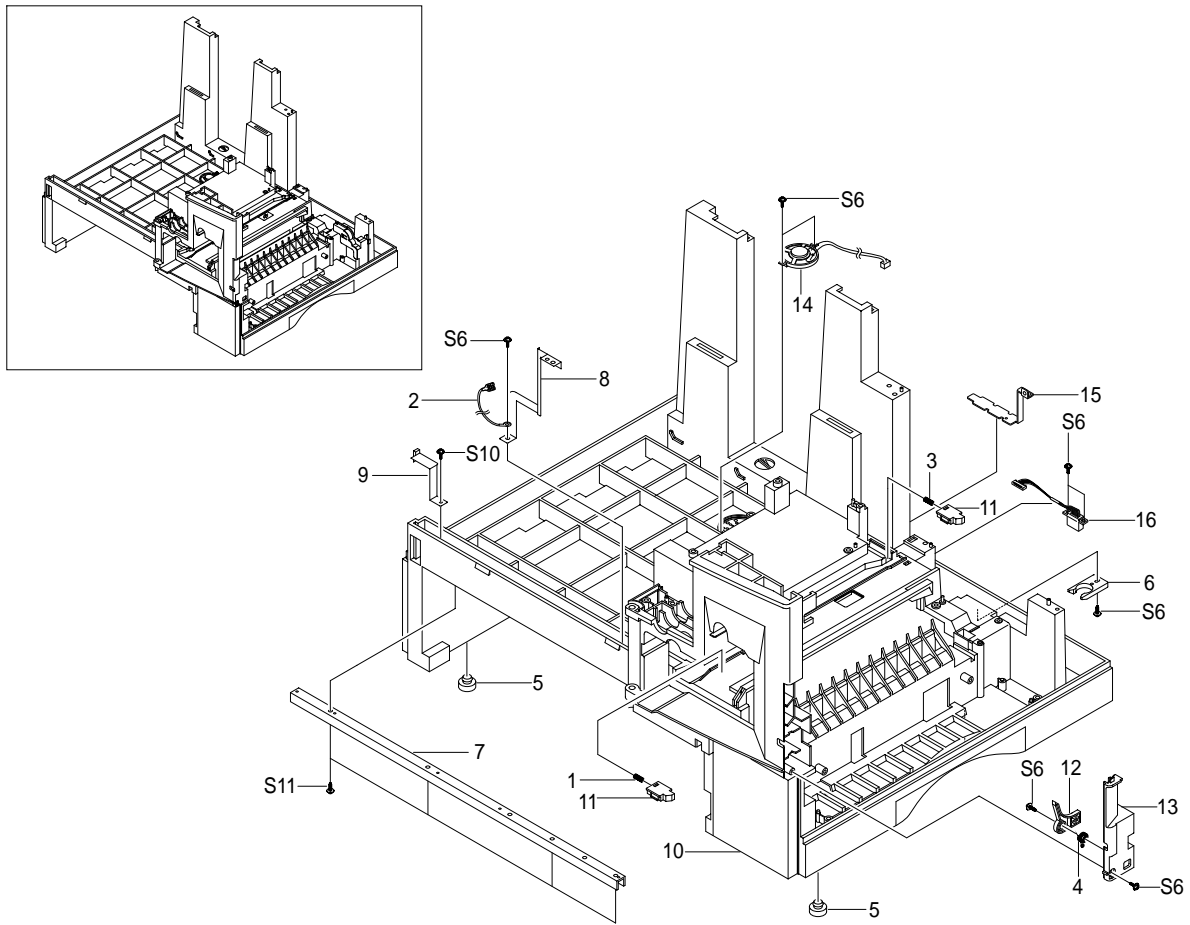

#### Base Frame Parts List

( SA. : Service Available )

NO	DESCRIPTION	SEC CODE	Q'TY	SA	REMARK
0	ELA HOU-BASE FRAME ASS'Y	JC96-02414A	1	O	
1	SPRING ETC-DEVE FRONT	*	1	X	
2	CBF HARNESS-OPC GND	*	1	X	
3	SPRING ETC-DEVE REAR	*	1	X	
4	SPRING ETC-TORSION	*	1	X	
5	FOOT-ML80	JC61-40001A	2	O	
6	CAM-CATCH	*	1	X	
7	IPR-CHANNEL BASE FRAME	*	1	X	
8	IPR-GROUND PLATE A(OPC)	JC70-00240A	1	O	
9	IPR-GROUND PLATE B(BASE)	JC70-00241A	1	O	
10	PMO-BASE FRAME	*	1	X	
11	PMO-BRACKET PUSH DEVE	*	2	X	
12	PMO-BRACKET SIDE OPEN	JC72-00781A	1	O	
13	PMO-COVER FRONT DUMMY	*	1	X	
14	ELA M/MEDIO AUD-SPEAKER	JC96-01607A	1	O	
15	IPR-GROUND PLATE SCF	JC70-00243A	1	O	
16	CBF HARNESS SCF	JC39-00082A	1	O	

O : Service available X : Service not available

## 5-12.Pick-up Ass'y Exploded View & Parts List

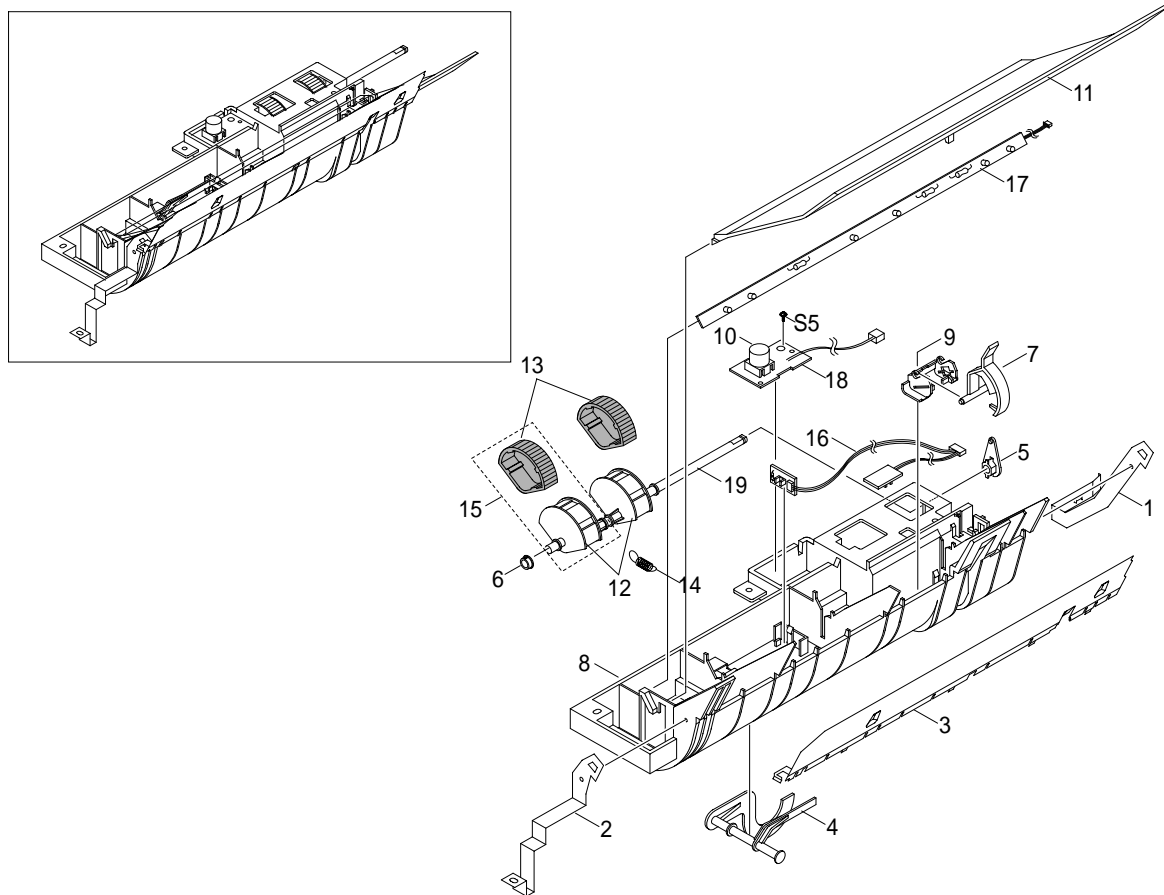

### Pick-up Ass'y Parts List

( SA. : Service Available )

NO	DESCRIPTION	SEC CODE	Q'TY	SA	REMARK
0	ELA HOU-PICKUP ASS'Y	JC96-02180A	1	O	
1	IPR-GND FEED	*	1	X	
2	IPR-GND INPUT	JC70-00235A	1	O	
3	IPR-GUIDE INPUT	JC70-00222A	1	O	
4	PMO-ACTUATOR EMPTY	JC72-00719A	1	O	
5	PMO-BEARING SHAFT	JC72-41191A	1	O	
6	PMO-BUSHING_P/U, MP	*	1	X	
7	PMO-FEED SENSOR	*	1	X	
8	PMO-GUIDE PAPER	*	1	X	
9	PMO-HOLDER SENSOR FEED	*	1	X	
10	PMO-LENS TONER SENSOR	*	1	X	
11	PMO-PTL PATH	*	1	X	
12	PMO-SHAFT PICK UP	*	1	X	
13	RPR-RUBBER PICK UP	JC73-00086A	2	O	
14	SPRING-PICKUP	JC61-00482A	1	O	
16	PBA SUB-FEED+P.EMP SEN.	JC92-01363A	1	O	
17	PBA SUB-PTL	JC92-01361A	1	O	
18	PBA SUB-TONER_TX	JC92-01359A	1	O	
19	PICK UP, CSTAS (FRU)	JC81-00428A	1	O	

O : Service available X : Service not available

### 5-13. Drive Ass'y Exploded View & Parts List

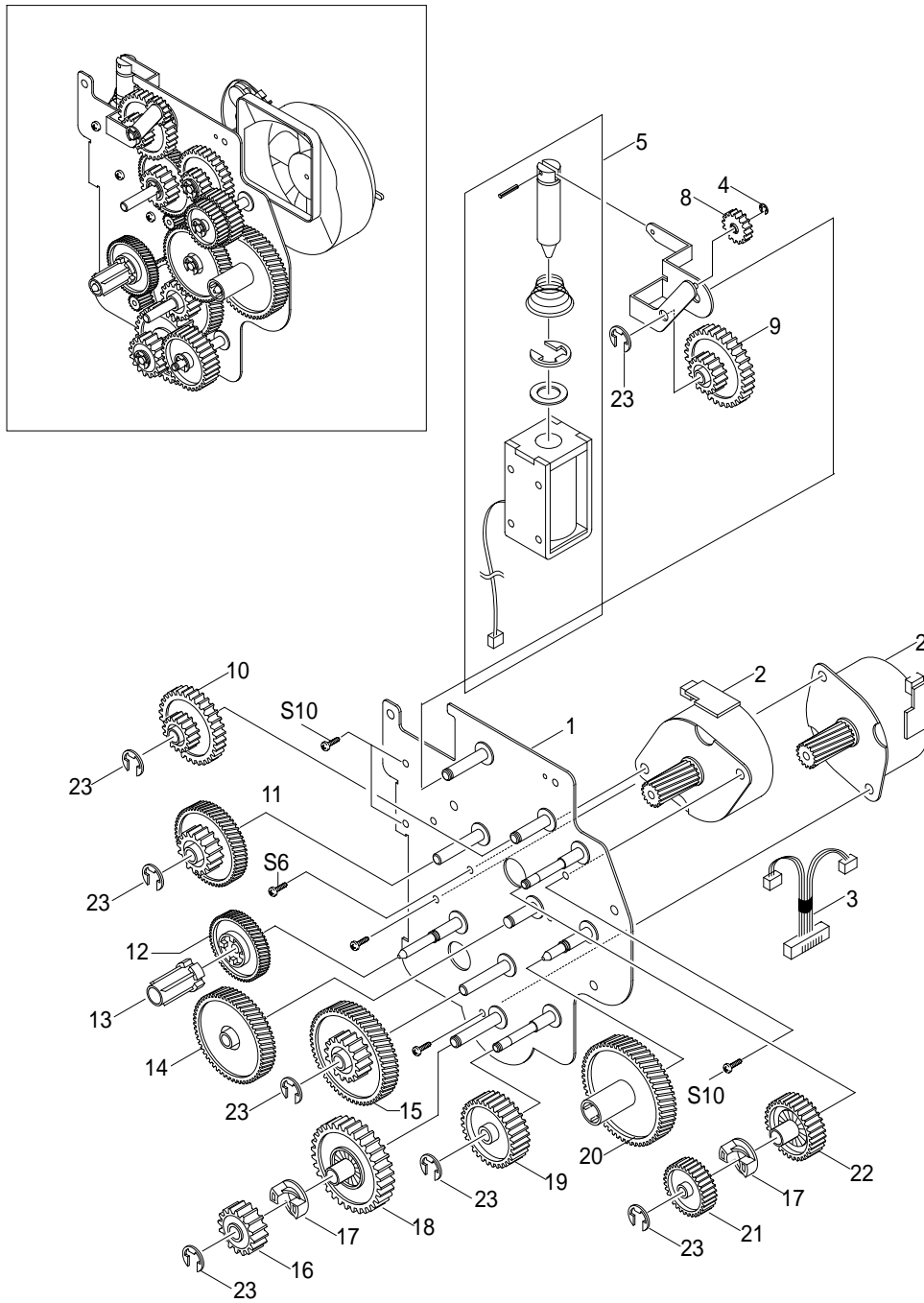

## Drive Ass'y Parts List

( SA. : Service Available )

NO	DESCRIPTION	SEC CODE	Q'TY	SA	REMARK
0	ELA HOU-DRIVE ASS'Y	JC96-02181A	1	O	
1	IPR-BRKT MOTOR	*	1	X	
2	MOTOR-STEP	JC31-00002B	2	O	
3	CBF-HARNESS-MOTOR	*	1	X	
4	RING-C	*	1	X	
5	SOLENOID-DUPLEX	JC33-00008A	1	O	
6	SPRING SOLENOID DP	*	1	X	
7	IPR-LINK SOLENOID	*	1	X	
8	GEAR-EXIT/U,ID	*	1	X	
9	GEAR-SWING DRV	*	1	X	
10	GEAR-35/19	*	1	X	
11	GEAR-71/23	*	1	X	
12	GEAR-DEVE DRV	*	1	X	
13	PMO-DEV/COUPLING	*	1	X	
14	GEAR-RDCN,OPC	*	1	X	
15	GEAR-86/23	*	1	X	
16	GEAR-RDCN FEED OUTER	*	1	X	
17	GEAR-HUB CLUTCH	*	2	X	
18	GEAR-RDCN FEED INNER	*	1	X	
19	GEAR-FEED DRV	*	1	X	
20	GEAR-OPC DRV	*	1	X	
21	GEAR-GEAR FUSER DRV OUTER	*	1	X	
22	GEAR-FUSER DRV INNER	*	1	X	
23	RING-E	*	7	X	

O : Service available X : Service not available

### 5-14. Main Frame Ass'y Exploded View & Parts List

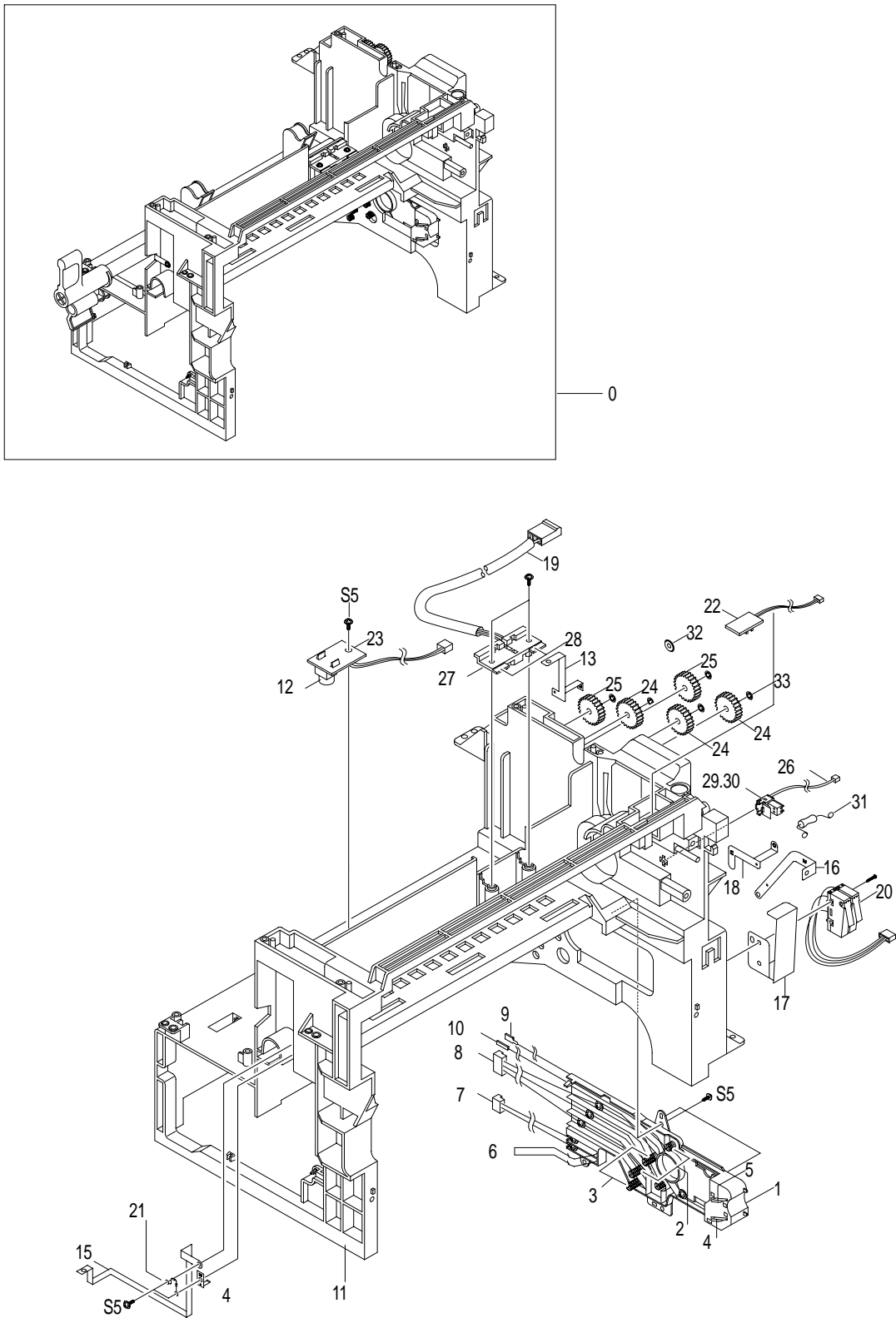

## Main Frame Ass'y Parts List

( SA : Service Available )

NO	DESCRIPTION	SEC CODE	Q'TY	SA	REMARK
0	ELA HOU-FRAME MAIN ASS'Y	JC96-02184A	1	O	
1	PMO-HOUSING TERMINAL	JC72-00802A	1	O	
2	IPR-TERMINAL BLADE	*	2	X	
3	IPR-TERMINAL SUPPLY	*	2	X	
4	IPR-TERMINAL TR	*	1	X	
5	IPR-TERMINAL GND	*	1	X	
6	IPR-TERMINAL DEVE KEY	*	2	X	
7	CBF-HARNESS-DEV-ID	*	1	X	
8	CBF-HARNESS-BLADE+SUPPLY+DEV	*	1	X	
9	CBF-HARNESS-THV WIRE	*	1	X	
10	CBF-HARNESS-MHV WIRE	*	1	X	
11	PMO-FRAME MAIN	*	1	X	
12	PMO-LENS TONER SENSOR	*	1	X	
13	IPR-GND EXIT	*	1	X	
14	IPR-GND OPC	*	1	X	
15	IPR-GND OPC BASE	*	1	X	
16	IPR-GND FUSER	*	1	X	
17	IPR-GUARD C/O S/W	*	1	X	
18	IPR-GND TERMINAL	*	1	X	
19	CBF HARNESS-AC WIRE	*	1	X	
20	AS-SWITCH MICRO(FRU)	JC81-00438A	1	O	
21	CBF-HARNESS-EARTH(TX MOTOR)	*	1	X	
22	PBA SUB-EXIT SENSOR	JC92-01364A	1	O	
23	PBA SUB-TONER_RX	JC92-01360A	1	O	
24	GEAR-EXIT/U,ID	*	3	X	
25	GEAR-EXIT,IDLE(Z17)	*	2	X	
26	CBF-HARNESS THERMISTOR_JOINT	JC39-00164A	1	O	
27	PMO-HOUSING TERMINAL	*	1	X	
28	IPR-TERMINAL FU	*	2	X	
29	PMO-CAP CONNECTOR L	JC72-00463A	1	O	
30	PMO-CAP CONNECTOR U	JC72-00465A	1	O	
31	ELA HOU-MOTOR GND	*	1	X	
32	SPRING-CLUTCH	*	2	X	
33	RING-CS	*	5	X	

O : Service available X : Service not available

## 5-15. Fuser Ass'y Exploded View & Parts List

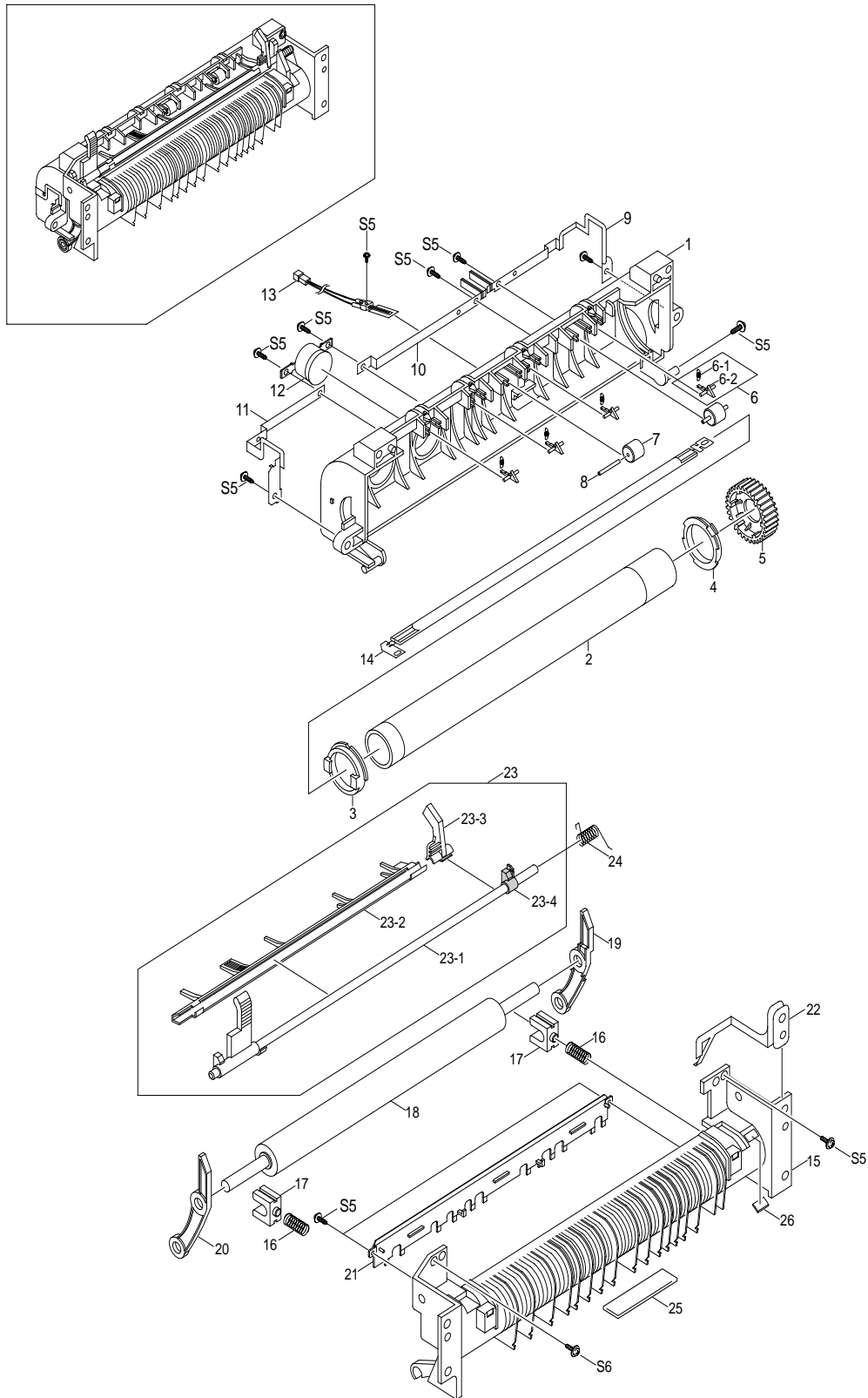

## Fuser Ass'y Parts List

( SA. : Service Available )

NO	DESCRIPTION	SEC CODE	Q'TY	SA	REMARK
0	ELA HOU-FUSER(110V)ASS'Y	JC96-02194A	1	O	110V
0	ELA HOU-FUSER(220V)ASS'Y	JC96-02178A	1	O	220V
1	PMO-UPPER FUSER	*	1	X	
2	RMO-ROLLER HEAT	*	1	X	
3	PMO-BEARING H/R-F	*	1	X	
4	BEARING-H/R L	*	1	X	
5	GEAR-FUSER 7300	JC66-40913B	1	O	
6	MEA UNIT-CLAW ASS'Y	*	4	X	
6-1	SPRING-SAPERATION	*	1	X	
6-2	PMO-GUIDE CLAW	*	1	X	
7	PEX-ROLLER EXIT F-UP	*	2	X	
8	IPR-PIN ROLLER EXIT	*	2	X	
9	NPR-ELECTRODE GEAR	*	1	X	
10	NPR-ELECTRODE M	*	1	X	
11	NPR-ELECTRODE F	*	1	X	
12	THERMOSTAT	4712-000001	1	O	
13	THERMISTOR-FUSER	JC14-00001A	1	O	
14	LAMP-HALOGEN (110V)	4713-001158	1	O	110V
14	LAMP-HALOGEN(220V)	4713-001157	1	O	220V
15	PMO-LOWER FUSER	*	1	X	
16	SPRING-PR	*	1	X	
17	BEARING-PRESSURE/R	*	2	X	
18	RMO-ROLLER PRESSURE	*	1	X	
19	PMO-LEVER JAM R	*	1	X	
20	PMO-LEVER JAM F	*	1	X	
21	PMO-GUIDE INPUT	*	1	X	
22	IPR-GROUND FU	*	1	X	
23	MEA UNIT-ACTUATOR ASS'Y	JC97-01611A	1	O	
23-1	PMO-ACTUATOR EXIT	*	1	X	
23-2	PMO-GUIDE DUPLEX	*	1	X	
23-3	PMO-ARM ACTUATOR	*	1	X	
23-4	GUIDE REMOVE	*	1	X	
24	SPRING-ACTUATOR 6G	*	1	X	
25	LABEL(R)CAU_HOT.FU	*	1	X	
26	LABEL(R)-LV FUSER	*	1	X	110V
	LABEL(R)-HV FUSER	*	1	X	220V

O : Service available X : Service not available

## 5-16. SCF Ass'y Exploded View & Parts List

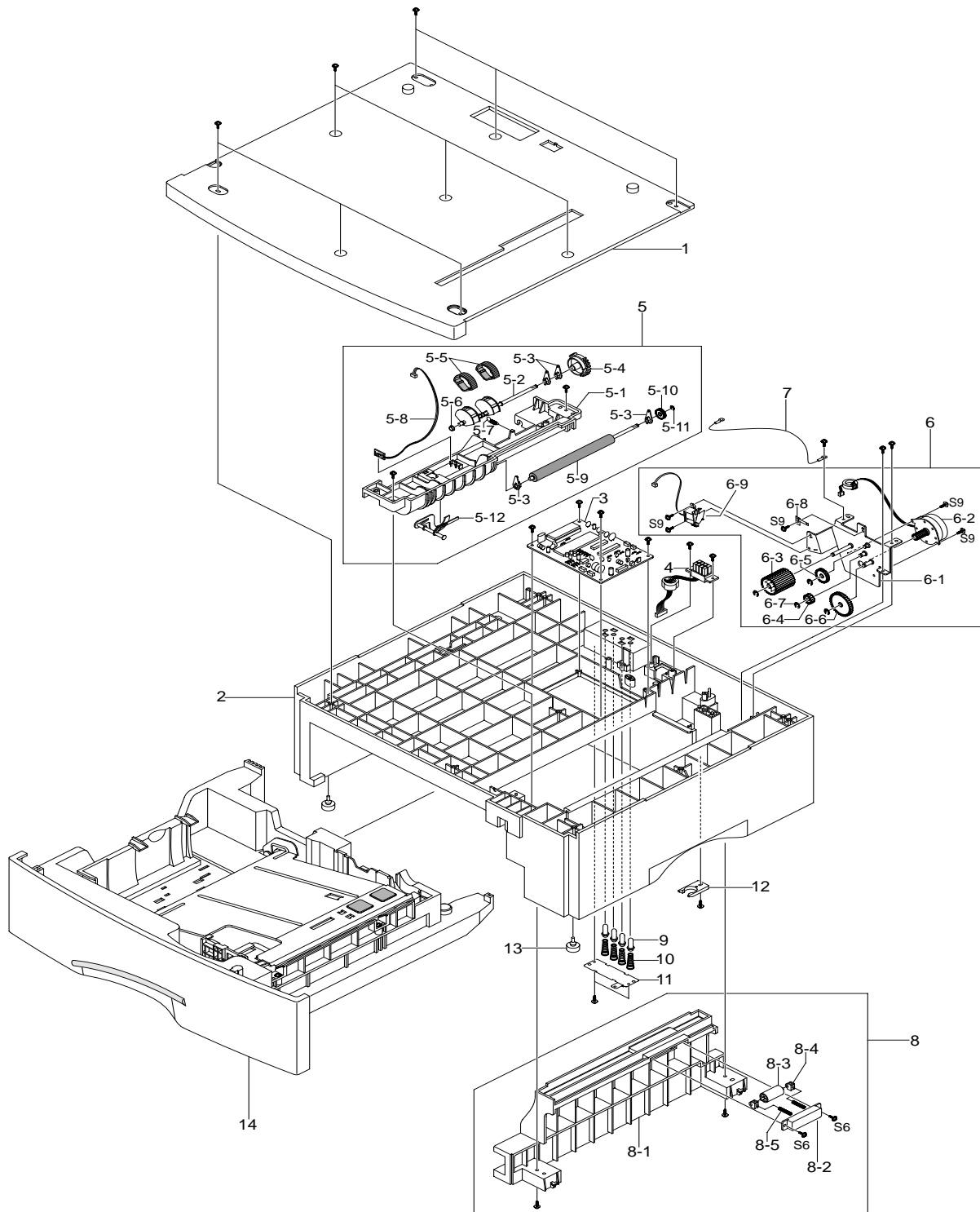

## SCF Ass'y Parts List

( SA. : Service Available )

NO	DESCRIPTION	SEC CODE	Q'TY	SA	REMARK
0	ELA UNIT-SCF ASS'Y(ZEUS)	*	1	X	OPTIONAL
1	PMO-COVER TOP SCF	*	1	X	
2	PMO-BASE FRAME-SCF	*	1	X	
3	PBA MAIN-SCF	*	1	X	
4	CBF HARNESS-SCF_8P	*	1	X	
5	MEA ETC-GUIDE PAPERUPPER SCF	*	1	X	
5-1	PMO-GUIDE PAPER UPPERSCF	*	1	X	
5-2	PMO-SHAFT PICK UP	*	1	X	
5-3	PMO-BEARING SHAFT	*	4	X	
5-4	GEAR-PICK UP	*	1	X	
5-5	RPR-RUBBER PICK UP	*	2	X	
5-6	PMO-BUSHING_P/U,MP	*	1	X	
5-7	SPRING ETC-PICKUP	*	1	X	
5-8	PBA SUB-BIN_FULL_SEN.	*	1	X	
5-9	RPR-ROLLER FEED SCF	*	1	X	
5-10	GEAR-FEED (SCF)	*	1	X	
5-11	RING-E	*	1	X	
5-12	PMO-ACTUATOR EMPTY	*	1	X	
6	ELA HOU-MOTOR SCF	*	1	X	
6-1	IPR-BRKT GEAR	*	1	X	
6-2	MOTOR-SCF	*	1	X	
6-3	GEAR-P/UP DRV SCF	*	1	X	
6-4	GEAR-IDLER OPTION	*	1	X	
6-5	GEAR-IDLE(Z=30)	*	1	X	
6-6	GEAR-IDLE(SCF)	*	1	X	
6-7	RING-E	*	4	X	
6-8	IPR-GROUND_ROLLER	*	1	X	
6-9	SOLENOID-PICK UP	*	1	X	
7	CBF HARNESS-GND	*	1	X	
8	ELA HOU-GUIDE PAPER LOWERSCF	*	1	X	
8-1	PMO-GUIDE PAPER LOWER	*	1	X	
8-2	PMO-HOLDER IDLE ROLL16	*	1	X	
8-3	PMO-IDLE ROLLER SCF16	*	1	X	
8-4	PMO-BUSH IDLE ROLL-SCF16	*	2	X	
8-5	SPRING ETC-PAD	*	2	X	
9	ICT-SHAFT HV LARGE	*	4	X	
10	SPRING ETC--HV LARGE	*	4	X	
11	IPR-PLATE GROUND(A)	*	1	X	
12	CAM-CATCH	*	1	X	
13	FOOT-ML80	*	2	X	
14	MEA UNIT-CASSETTE(A4) ASS'Y	*	1	X	

O : Service available X : Service not available

## 5-17. Screw

NO	SEC CODE	DESCRIPTION	SPEC	
S1	6006-000127	SCREW-ASS'Y MACH	"WS,PH,+,M3,L6,ZPC(YEL),MSWR15"	
S2	6001-000568	SCREW-MACHINE	"PH,+,M3,L8,NI PLT,SM20C,-"	
S3	6002-000175	SCREW-TAPPING	"PWH,+,2,M3,L8,ZPC(YEL),SM20C"	
S4	6002-000351	SCREW-TAPPING	"PH,+,2,M2,L8,ZPC(YEL),SM20C"	
S5	6003-000119	SCREW-TAPTITE	"BH,+,B,M3,L8,CBLACK,SWRCH18A"	
S6	6003-000196	SCREW-TAPTITE	"PWH,+,B,M3,L10,NI PLT,SWRCH18A"	
S7	6003-000198	SCREW-TAPTITE	"PWH,+,B,M3,L12,ZPC(YEL),SWRCH1"	
S8	6003-000221	SCREW-TAPTITE	"PWH,+,S,M4,L8,ZPC(YEL),SWRCH18"	
S9	6003-000266	SCREW-TAPTITE	"PWH,+,S,M3,L6,ZPC(YEL),SWRCH18"	
S10	6003-000269	SCREW-TAPTITE	"BH,+,S,M3,L6,ZPC(YEL),SWRCH18A"	

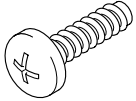
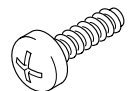
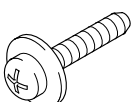

NO	SEC CODE	DESCRIPTION	SPEC	
S11	6003-001256	SCREW-TAPTITE	"BH,+,B,M4,L10,NI PLT,SWRCH18A"	
S12	6002-000319	SCREW-TAPPING	"PH,+,2,M3,L8,ZPC(YEL),SM20C"	
S13	6003-000267	SCREW-TAPTITE	"PWH,+,S,M3,L8,ZPC(YEL),SWRCH18"	

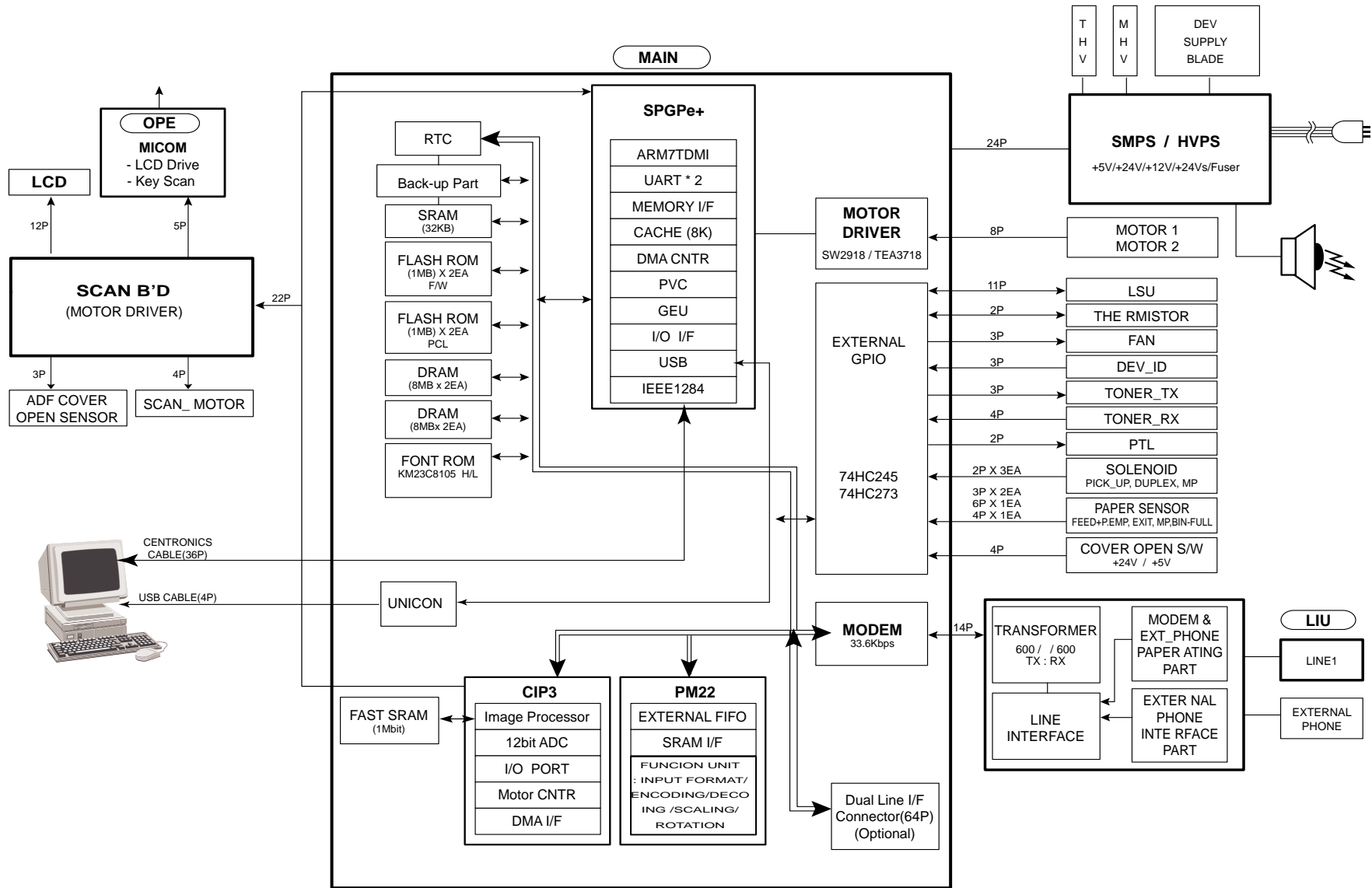

# 6. Block Diagrams



# 7. Connection Diagrams

**REMARK**  
 : Normal Connector  
 : Board on type Connector

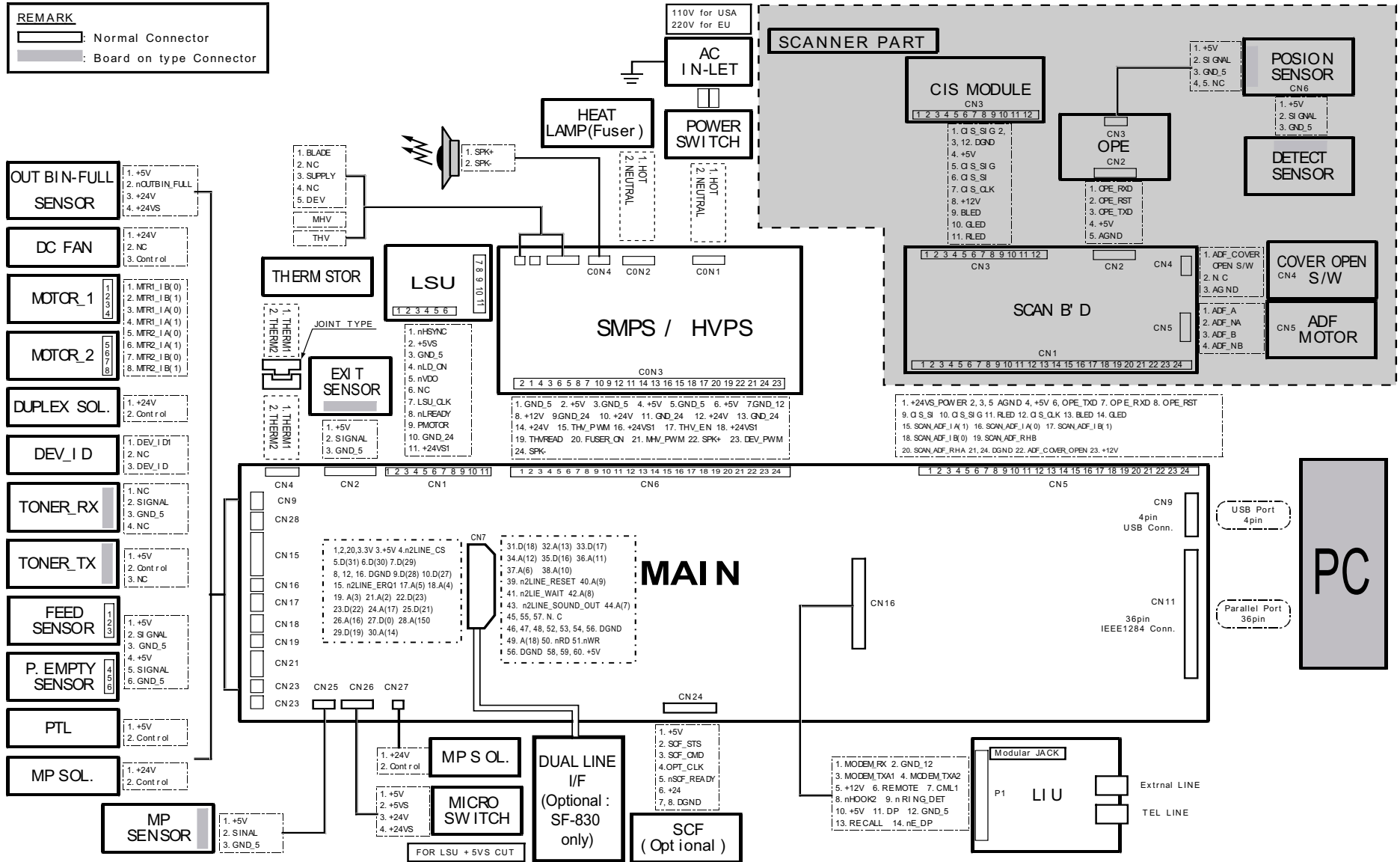

# 8. Dual Line Option

## 8-1 Introduction

Dual Line has two communications line ports. Each Line supports maximum 33.6kbps Modem speed. It is designed by Master and Slave Board. Each board has its own processor, communicate with shared memory. The below shows how to communicate each other.

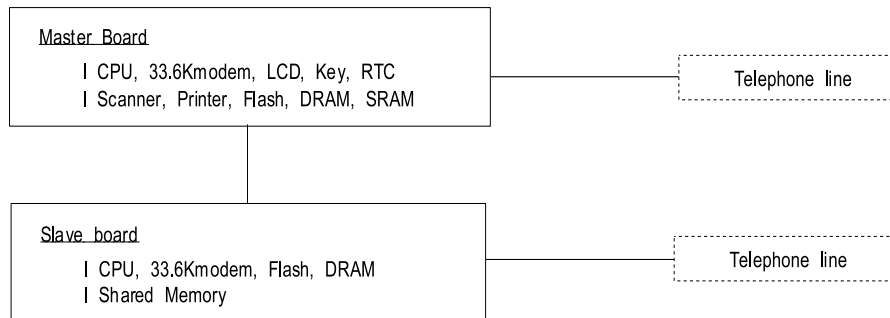

### 8-1-1 Master Board Role

It is independent Fax Board. It scan image and print received fax image. Also It transmit scanned image and receive image from remote fax. It supports 33.6kbps Modem . It detects all kinds of key from keyboard. It displays current status on the LCD. It can dial the number according to pre- programmed dial number like general Telephone set. Also it print out various reports such as transmission and reception results.

### 8-1-2 Slave Board Role

This board has transmission and reception capability without scanner, printer. This board receive all data from Master Board and send image to remote fax. In case of receive from remote fax, it sends signal to Master Board to notify Event, then received data would transferred to Master Board. The Master Board Received image from Slave Board and save them to User Memory. So there should be some specification between Master Board and Slave Board.

## 8-2 Specification

ITEM		Description
NetBridge Chip		Samsung NETBRIDGE
Hardware	CPU	32bit RISC Processor, KS32C65100, 30MHz
	Flash Memory	1 Mbyte
	DRAM	2 Mbyte
	Modem	FM336R66719, 33.6Kbps
	Shared memory	64Kbyte SRAM
Communication mode		Half-Duplex
Max. modem speed		33.6Kbps
Coding		MH, MR, MMR
Dimension(HxWxD)		15 x 130 x 90
Power Consumption		Max. 0.8A / +5VDC

## 8-3 Dual Line Board Connector Pin Assignment

ITEM	Description	Pin No.	Idle	Active	In/Out
Dual Line Interface (CN3)	Addr 0 ~Addr 15	21, 19, 18, 17, 37, 44, 42, 40, 38, 36, 34, 32, 30, 28, 26, 24	Pulse	Pulse	I
	Data 0 ~ Data 15	35, 33, 31, 29, 27, 25, 23, 22, 14, 13, 11, 10, 9, 7, 6, 5	Pulse	Pulse	I/O
	nDL_WAIT	41	+5V	DGND	O
	nDL_RST	39	+5V	DGND	I
	nDL_CS	4	+5V	DGND	I
	nDL_ERQ1	15	+5V	DGND	O
	nDL_RD	50	+5V	DGND	I
	nDL_WR	51	+5V	DGND	I
	DL_SOUND_OUT	43	DGND	+5V	O
	+5V	3, 58, 58, 60	+5V	+5V	-
	DGND	8, 12, 16, 48, 52, 56	DGND	DGND	-
LIU Interface (CN2)	MODEM_RX	1	DGND	AC signal	I
	MODEM_TXA1	3	DGND	AC signal	O
	MODEM_TXA2	4	DGND	AC signal	O
	REMOTE	6	DGND	+5V	I
	nHOOK_OFF2	8	+5V	DGND	I
	CML1	7	DGND	+5V	O
	nRING_DET	9	+5V	DGND	I
	DP	11	DGND	+5V	O
	RECALL	13	DGND	+5V	O
	nE_DP	14	+5V	DGND	O
	+12V	5	+12V	+12V	-
	DGND	2, 12	DGND	DGND	-
	Serial Connector (CN1)	+5V	1	+5V	+5V
TxD		2	+5V	Pulse	O
RxD		3	+5V	Pulse	I
DGND		4	DGND	DGND	-

## 8-4 Troubleshooting of Dual Line Board

### 8-4-1 Troubleshooting Flow Chart

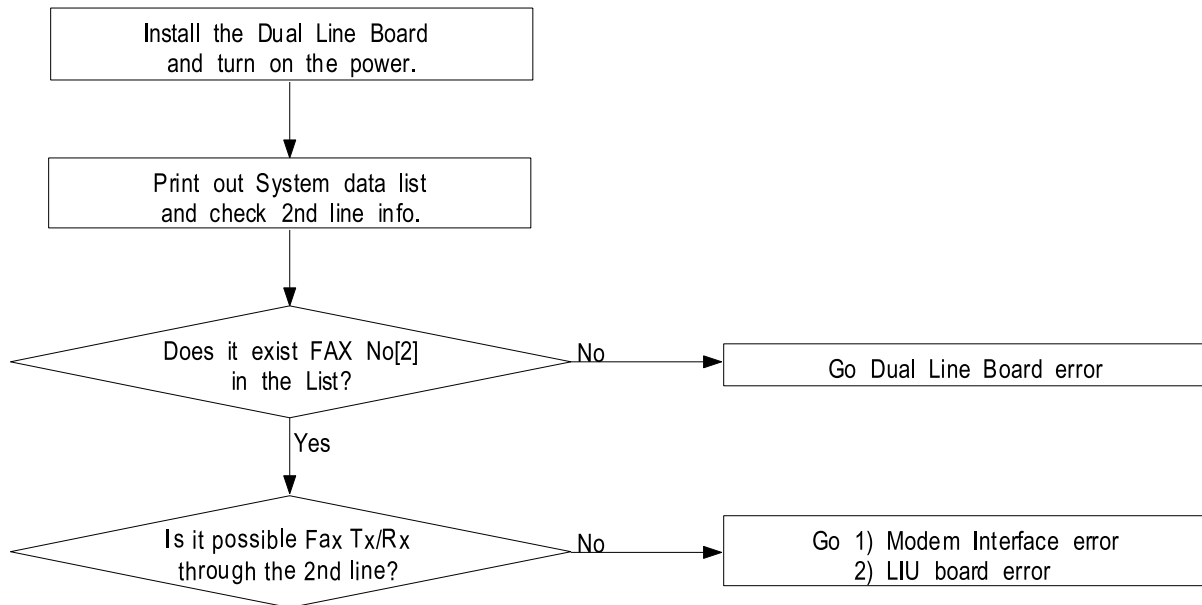

### 8-4-2 Dual Line Board error

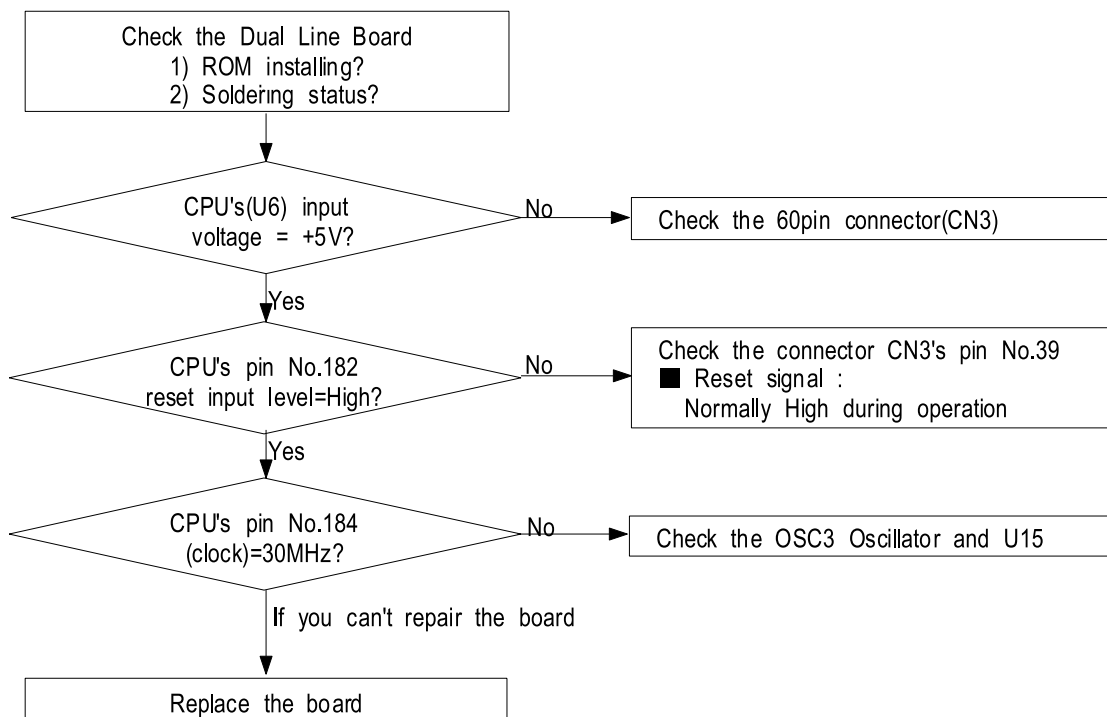

### 8-4-3 Modem interface error

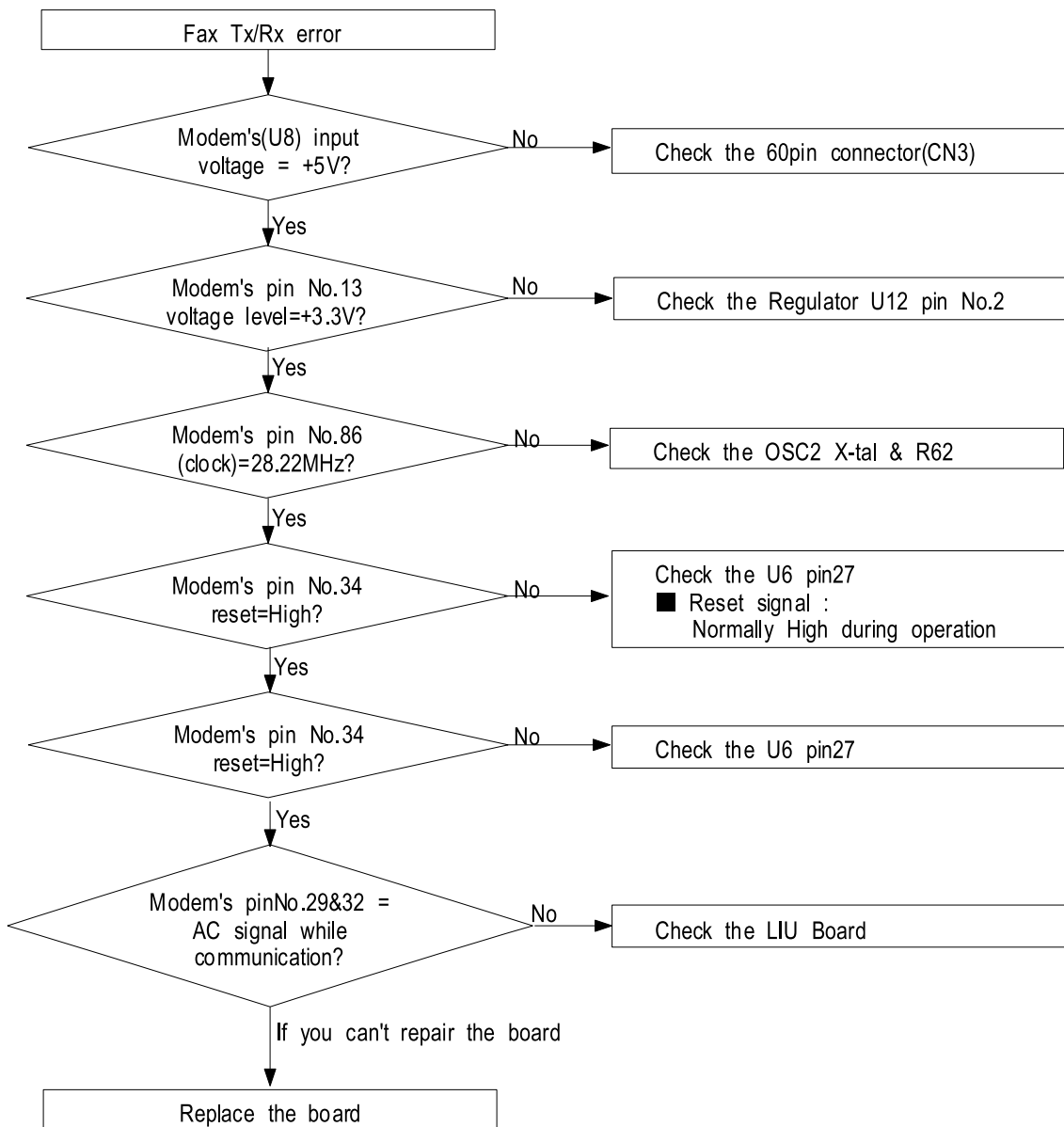

8-4-4 LIU interface error

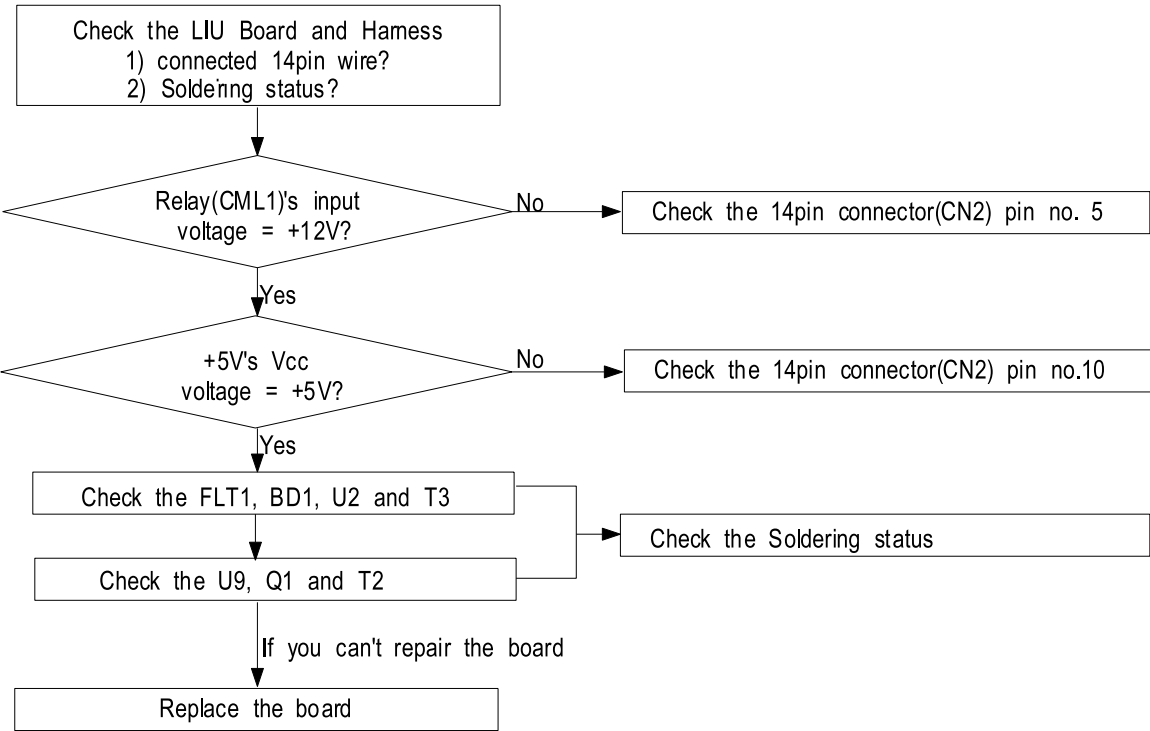



# *Repair Manual*

## **Digital Laser MFP**

SF-835P / SF-830  
Msys835P / Msys830

### CONTENTS

1. Block Diagram
2. Connection Diagram
3. Circuit Description
4. Schematic Diagrams

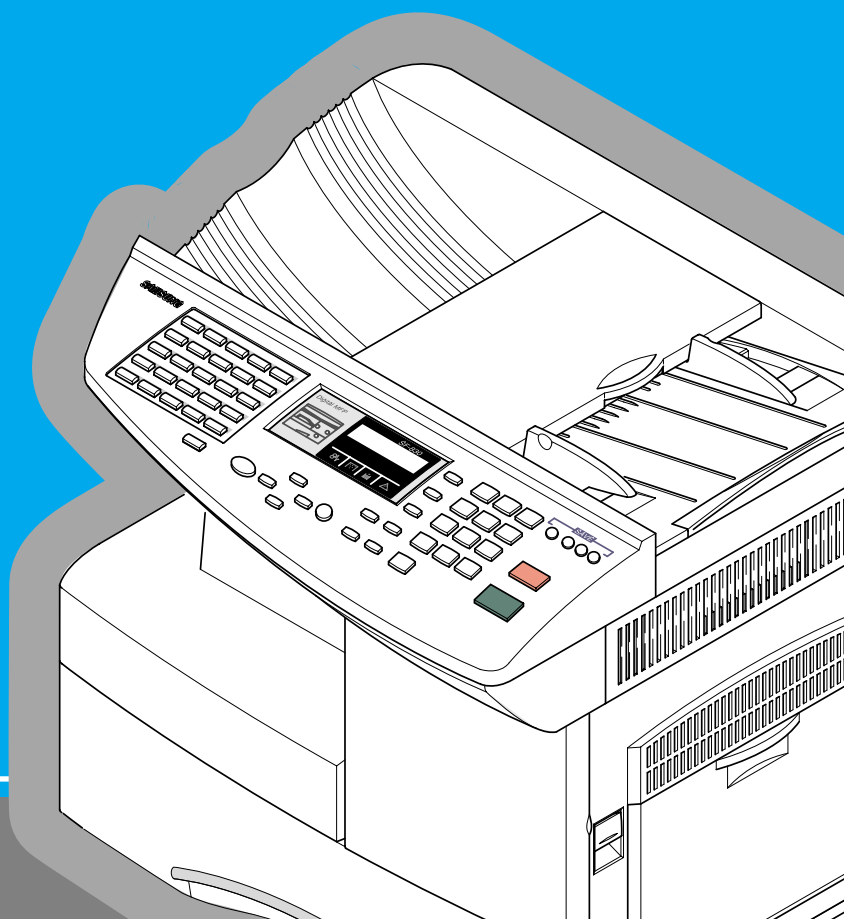



The Samsung logo, consisting of the word "SAMSUNG" in white capital letters inside a blue oval.

*This manual is made and  
described centering around  
circuit diagram  
and circuit description needed  
in the repair center  
in the form of appendix.*

**Samsung Electronics Digital Printing  
CS Group**

Copyright (c) 2002. 02

# 1. Block Diagram

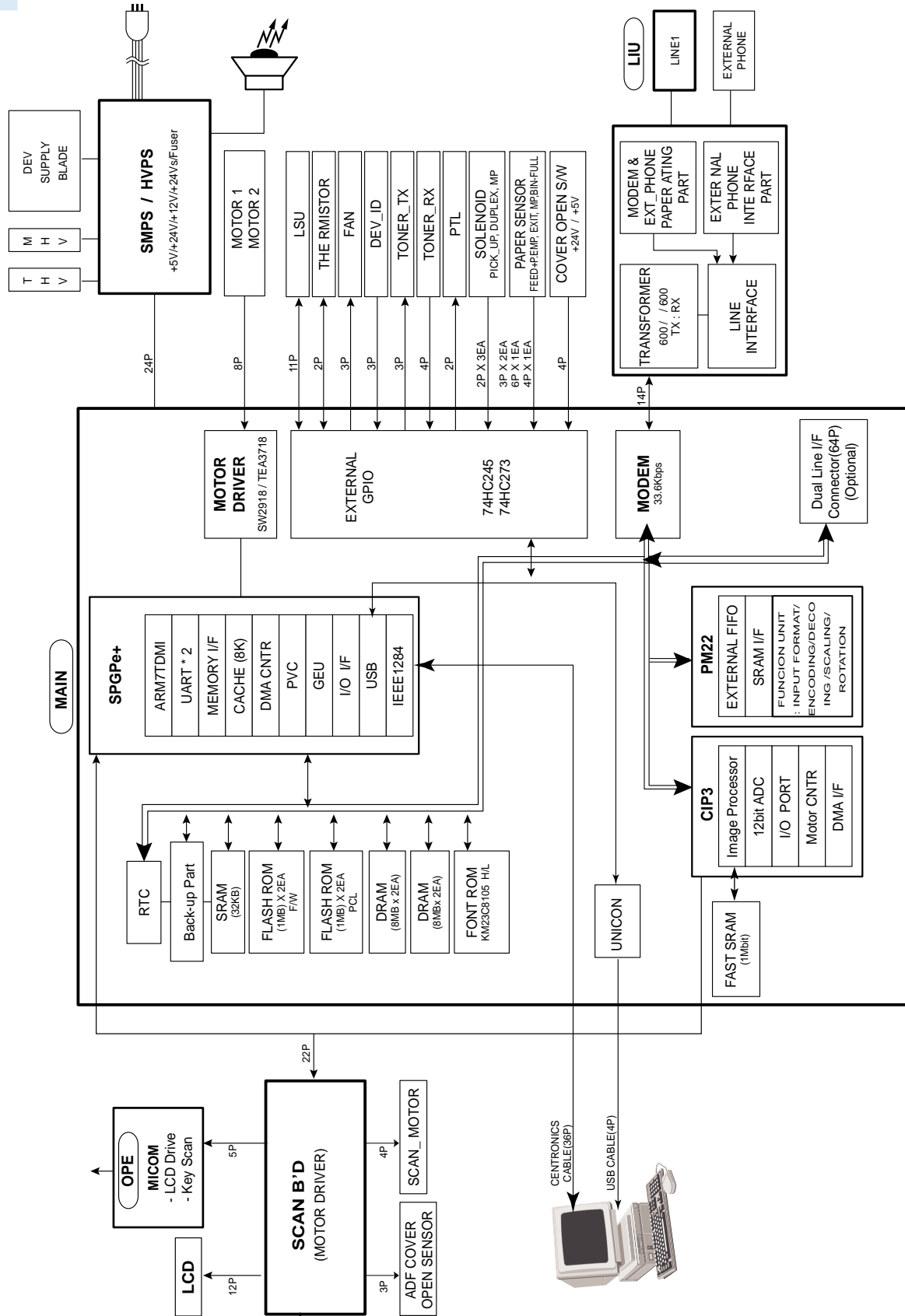

# 2. Connection Diagram

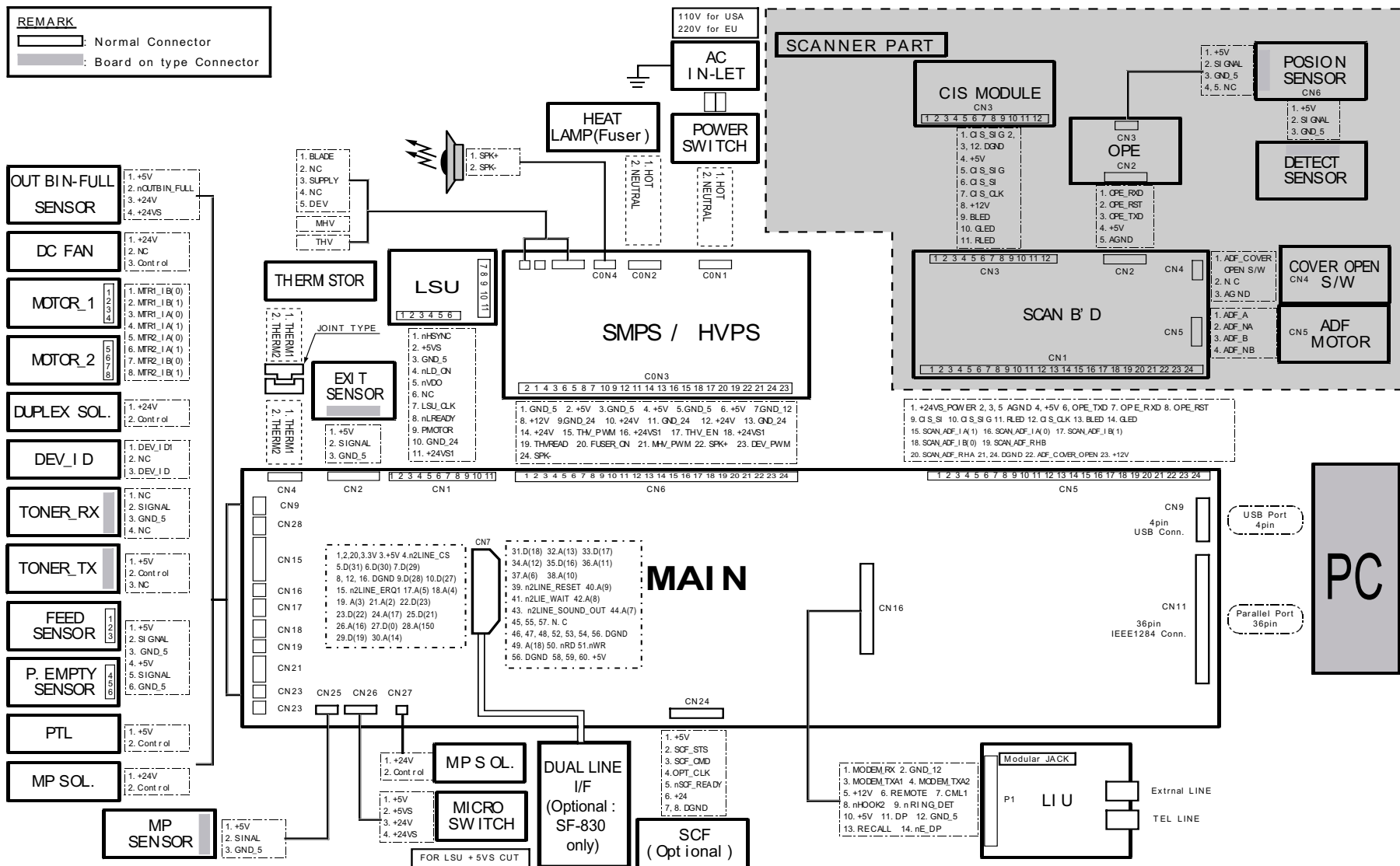

# 3. Circuit Description

## • Main B'D

### 3-1 Main PBA

#### 3-1-1 SUMMARY

The main circuit that consists of CPU, MFP controller (built-in 32bit RISC processor core: ARM7TDMI) including various I/O device drivers, system memory, scanner, printer, motor driver, PC I/F, and FAX transceiver controls the whole system. The entire structure of the main circuit is as follows :

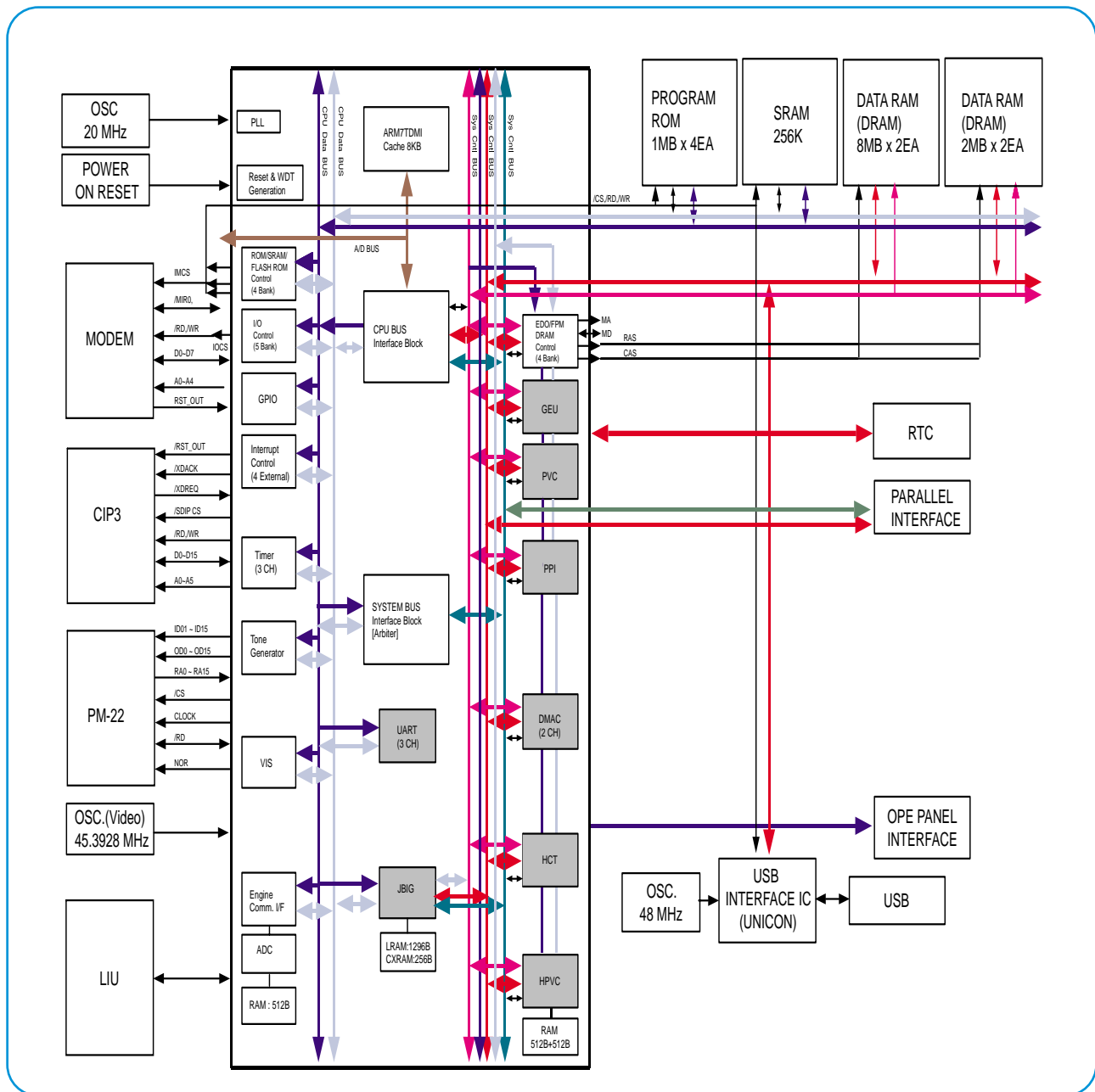

<Block Diagram>

### 3-2 Circuit Operation

#### 3-2-1 CLOCK

##### 1) System Clock

Device	Oscillator
Frequency	20 MHz±%

- KS32C61200 RISC PROCESSOR: drives PLL internally and uses 60MHz.

##### 2) Video Clock

Device	Oscillator
Frequency	45.3928 MHz±%

- $F_{vd} = ((\text{PAPER 1SCAN LINE sending time} * \text{SCAN effective late} / \text{1SCAN LINE DOT \#}) * 4) = (600\text{dpi} * 600\text{dpi} * 58.208\text{mm/s} * 216\text{mm}^4) / (25.4\text{mm} * 25.4\text{mm} * 76.1\%) = 28.697\text{MHz}$
- PAPER 1SCAN LINE sending time = SCAN LINE interval / DOCUMENT SPEED (58.208mm/S)
- 1SCAN LINE DOT # = MAZ SCAN distance (216mm) \* DOT# per 1mm

##### 3) USB Clock

Device	Oscillator
Frequency	48 MHz±%

##### 4) PM-22 Clock

Device	Oscillator
Frequency	66 MHz±%

#### 3-2-2 POWER ON/OFF RESET

##### 1) Signal Operation

Input Signal	+5V Power Line (VCC)
Output Signal	KS32C61200 nRESET 29F800B nRESET

- POWER ON/OFF DETECT                      VCC RISING/FALLING 4.5°±4.6V

RESET TIME (Td)	1.48~1.52ms
-----------------	-------------

- $T_d = (C_t * V_{\text{sensing}}) / I_{\text{charge}}$  (...  $C_t = 33\mu\text{F}$ ,  $I_s = 100\mu\text{A}$ )

##### 2) TIMING CHART

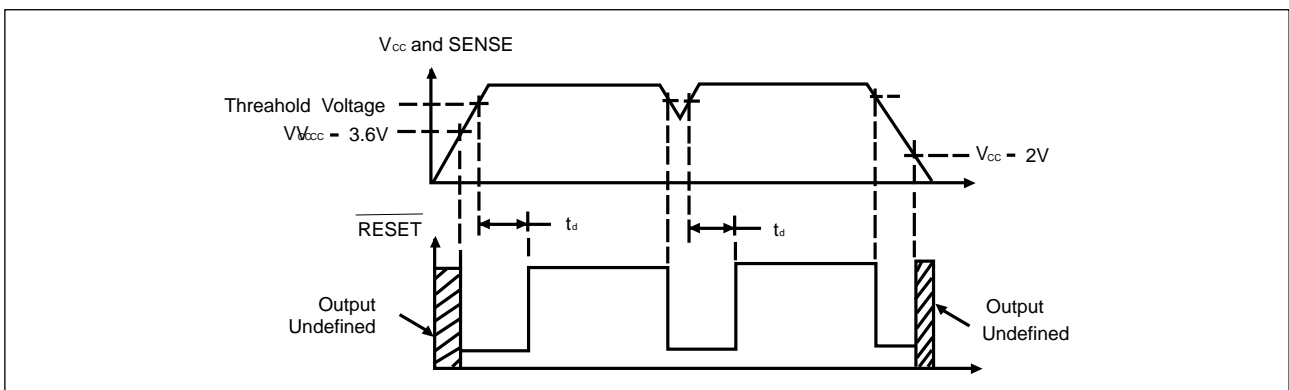

### 3-2-3 RISC MICROPROCESSOR

#### 1) RISC MICROPROCESSOR PIN & INTERFACE

No	Pin Name	I/O	Reset Value	Description	PAD
1	DATA0	I/O	Input	CPU Data Bus 0	PHBTT8, 8 mA
2	DATA1	I/O	"	CPU Data Bus 1	"
3	DATA2	I/O	"	CPU Data Bus 2	"
4	DATA3	I/O	"	CPU Data Bus 3	"
5	Vsso	Vss	-	5 V Gnd	
6	DATA4	I/O	Input	CPU Data Bus 4	PHBTT8, 8 mA
7	Vddo	Vdd	-	5 V	
8	DATA5	I/O	Input	CPU Data Bus 5	PHBTT8, 8 mA
9	DATA6	I/O	"	CPU Data Bus 6	"
10	DATA7	I/O	"	CPU Data Bus 7	"
11	DATA8	I/O	"	CPU Data Bus 8	"
12	Vssi	Vss	-	3.3 V Gnd	
13	DATA9	I/O	Input	CPU Data Bus 9	PHBTT8, 8 mA
14	Vddi	Vdd		3.3 V	
15	DATA10	I/O	Input	CPU Data Bus 10	PHBTT8, 8 mA
16	DATA11	I/O	"	CPU Data Bus 11	"
17	DATA12	I/O	"	CPU Data Bus 12	"
18	DATA13	I/O	"	CPU Data Bus 13	"
19	Vsso	Vss	-	5 V Gnd	
20	DATA14	I/O	Input	CPU Data Bus 14	PHBTT8, 8 mA
21	DATA15	I/O	"	CPU Data Bus 15	"
22	DATA16	I/O	"	CPU Data Bus 16	"
23	DATA17	I/O	"	CPU Data Bus 17	"
24	Vsso	Vss	-	5 V Gnd	
25	DATA18	I/O	Input	CPU Data Bus 18	PHBTT8, 8 mA
26	DATA19	I/O	"	CPU Data Bus 19	"
27	DATA20	I/O	"	CPU Data Bus 20	"
28	DATA21	I/O	"	CPU Data Bus 21	"
29	Vddi	Vdd	-	3.3 V	
30	DATA22	I/O	Input	CPU Data Bus 22	PHBTT8, 8 mA

No	Pin Name	I/O	Reset Value	Description	PAD
31	Vssi	Vss	-	3.3 V Gnd	
32	DATA23	I/O	Input	CPU Data Bus 23	PHBTT8, 8 mA
33	DATA24	I/O	"	CPU Data Bus 23	"
34	Vddp	Vdd	-	5 V	
35	DATA25	I/O	Input	CPU Data Bus 23	PHBTT8, 8 mA
36	Vssp	Vss	-	5 V Gnd	
37	DATA26	I/O	Input	CPU Data Bus 23	PHBTT8, 8 mA
38	DATA27	I/O	"	CPU Data Bus 23	"
39	Vddo	Vdd	-	5 V	
40	DATA28	I/O	Input	CPU Data Bus 23	PHBTT8, 8 mA
41	Vsso	Vss	-	5 V Gnd	
42	DATA29	I/O	Input	CPU Data Bus 23	PHBTT8, 8 mA
43	DATA30	I/O	"	CPU Data Bus 23	"
44	DATA31	I/O	"	CPU Data Bus 23	"
45	Vssi	Vss	-	3.3 V Gnd	
46	LFIA0 / OP4	O	H	Line Feed Motor Phase A	PHOB4, 4mA
47	Vddi	Vdd	-	3.3 V	
48	LFIA1 / OP5	O	H	Line Feed Motor Phase /A	PHOB4, 4mA
49	LFIB0 / OP6	O	"	Line Feed Motor Phase B	"
50	LFIB1 / OP7	O	"	Line Feed Motor Phase /B	"
51	TnRST	I		TAP Controller Reset	PHIT
52	TMS	I		TAP Controller Mode Sel	PHIT
53	TDI	I		TAP Controller Data In	"
54	TCK	I		TAP Controller Clock	"
55	TDO	O		TAP Controller Data Out	PHOB4
56	AVdd	Vcca	-	Analog 3.3 V	
57	AVin[0]	I	-	Analog Input 0	PICA
58	AVin[1]	I	-	Analog Input 1	"
59	AVss	Vssa	-	Analog Gnd	
60	AVssAVin[2]	I	-	Analog Input 2	PICA

No	Pin Name	I/O	Reset Value	Description	PAD
61	AVref	I	-	Analog Positive Reference	PICA
62	nIOCS0	O	H	IO Chipselect 0	PHOB4, 4 mA
63	nIOCS2/ToneOut	O	"	IO Chipselect 2 / ToneOut	"
64	nIOCS3/BufferSel	O	"	IO Chipselect 2 / BufferSel	"
65	Vssi	Vss	-	3.3 V Gnd	
66	nSELECTIN	I	-	Select Input	PHIL, ST
67	nFAULT	O	H	Fault for Error Condition	PHOB8, 8 mA
68	nAUTOFD	I	-	Auto Feed	PHIL, ST
69	nINIT	I	-	Initialization	"
70	SELECT	O	L	Parallel Port Select	PHOB8, 8 mA
71	Vddp	Vdd	-	5 V	
72	PERROR	O	L	Paper Error	PHOB8, 8 mA
73	BUSY	O	"	Parallel Port Busy	PHOB8, 8 mA
74	nACK	O	H	Parallel Port Acknowledge	PHOB8, 8 mA
75	Vssp	Vss	-	5 V Gnd	
76	PD0	I/O	Input	Parallel Port Data 0	PHBTT8, 8 mA
77	PD1	I/O	"	Parallel Port Data	"
78	Vddi	Vcca	-	3.3 V	for Ring OSC
79	PD2	I/O	Input	Parallel Port Data	PHBTT8, 8 mA
80	PD3	I/O	"	Parallel Port Data	"
81	Vssi	Vssa	-	3.3 V Gnd	for Ring OSC
82	PD4	I/O	Input	Parallel Port Data	PHBTT8, 8 mA
83	PD5	I/O	"	Parallel Port Data	"
84	Vddo	Vdd	-	5 V	
85	PD6	I/O	Input	Parallel Port Data	PHBTT8, 8 mA
86	PD7	I/O	"	Parallel Port Data	"
87	nSTROBE	I	-	Data Strobe	PHIL, ST
88	Vsso	Vss	-	5 V Gnd	
89	RxD1 / CTin[2]	I	-	Uart 1 Rx Data	PHIL, ST
90	TxD1	O	H	Uart 1 Tx Data	PHOB4, 4 mA

No	Pin Name	I/O	Reset Value	Description	PAD
91	nDREQ1/RxD2/CTin[1]	I	-	DMA Request1/Uart 2 Rx D	PHIL, ST
92	nDMACK1 / Tx D2	O	H	DMA Ack1/Uart 2 Tx D	PHOB4, 4 mA
93	nIOCS1 / nIOCS5	O	"	IO CS1 / DMA IO1 CS	"
94	Vddi	Vdd	-	3.3 V	
95	nDREQ0 /IP1/CTin[0]	I	-	DMA Request0 / Input Port	PHIL, ST
96	nDMACK0 / OP1	O	H	DMA Ack1 / Out Port	PHOB4, 4 mA
97	nIOCS4 / OP2	O	"	DMA IO0 CS / Out Port	"
98	EIRQ0	I	-	External Interrupt 0	PHILU50, ST
99	EIRQ1	I	-	External Interrupt 1	"
100	EIRQ2	I	-	External Interrupt 2	"
101	nWait / EIRQ3	I	-	Wait Request / Ex. IRQ 3	"
102	Vssi	Vss	-	3.3 V Gnd	
103	VCLK	I	-	Video Clock Input	PHIC
104	Vddi	Vdd	-	3.3 V	
105	IP[7] / nFSYNC	I	-	Input Port / Frame Sync	PHIL, ST
106	nLSYNC	I	-	Line Sync	"
107	OP[8] / nPRINT	O	H	Out Port / Print Start	PHOB4, 4 mA
108	Vssi	Vss	-	3.3 V Gnd	
109	VDO	O	H	Video Data Output	PHOB16, 16mA
110	Vsso	Vss	-	5 V Gnd	
111	CCLK / PWM[0]	O	H	Com. Clock / PWM [0]	PHOB4, 4 mA
112	nEPRDY / RxD0	I	-	Engine Power Ready / Uart 0 Rx Data	PHIL, ST
113	nCBSY / Tx D0	O	H	Command Busy / Uart 0 Tx Data	PHOB4, 4 mA
114	nEMSG / PWM[1]	I/O	Input	Eng. Message / PWM [1]	PHBLT4,ST,4mA
115	nEBSY / nLsuReady	I	-	Eng. Busy / LSU Ready	PHIL, ST
116	nCMMSG / PWM[2]	O	H	Com. Busy / PWM [2]	PHOB4, 4 mA
117	Vddo	Vdd	-	5 V	
118	nDRAMCAS0	O	L	DRAM Cas Strobe 0	PHOB8, 8 mA
119	nDRAMCAS1	O	"	DRAM Cas Strobe 1	"
120	nDRAMCAS2	O	"	DRAM Cas Strobe 2	"

No	Pin Name	I/O	Reset Value	Description	PAD
121	nDRAMCAS3	O	L	DRAM Cas Strobe 3	PHOB8, 8 mA
122	Vsso	Vss	-	5 V Gnd	
123	nDRAMOE	O	H	DRAM Data Out Enable	"
124	nDRAMWE	O	H	DRAM Data Write Enable	"
125	Vssi	Vss	-	3.3 V Gnd	
126	nDRAMRAS0	O	L	DRAM Ras Strobe 0	PHOB8, 8 mA
127	Vddi	Vdd	-	3.3 V	
128	nDRAMRAS1	O	L	DRAM Ras Strobe 1	PHOB8, 8 mA
129	nDRAMRAS2	O	"	DRAM Ras Strobe 2	"
130	nDRAMRAS3	O	"	DRAM Ras Strobe 3	"
131	Vsso	Vss	-	5 V Gnd	
132	DRAMD0	I/O	Input	DRAM Data Bus 0	PHBTT12, 12mA
133	Vddo	Vdd	-	5 V	
134	DRAMD1	I/O	Input	DRAM Data Bus 1	PHBTT12, 12mA
135	DRAMD2	I/O	"	DRAM Data Bus 2	"
136	DRAMD3	I/O	"	DRAM Data Bus 3	"
137	DRAMD4	I/O	"	DRAM Data Bus 4	"
138	Vsso	Vss	-	5 V Gnd	
139	DRAMD5	I/O	Input	DRAM Data Bus 5	PHBTT12, 12mA
140	DRAMD6	I/O	"	DRAM Data Bus 6	"
141	DRAMD7	I/O	"	DRAM Data Bus 7	"
142	Vssi	Vss	-	3.3 V Gnd	
143	DRAMD8	I/O	Input	DRAM Data Bus 8	PHBTT12, 12mA
144	Vddi	Vdd	-	3.3 V	
145	DRAMD9	I/O	Input	DRAM Data Bus 9	PHBTT12, 12mA
146	DRAMD10	I/O	"	DRAM Data Bus 10	"
147	DRAMD11	I/O	"	DRAM Data Bus 11	"
148	Vssp	Vss	-	5 V Gnd	
149	DRAMD12	I/O	Input	DRAM Data Bus 12	PHBTT12, 12mA
150	Vddp	Vdd	-	5 V	

No	Pin Name	I/O	Reset Value	Description	PAD
151	DRAMD13	I/O	Input	DRAM Data Bus 13	PHBTT12, 12mA
152	DRAMD14	I/O	"	DRAM Data Bus 14	"
153	DRAMD15	I/O	"	DRAM Data Bus 15	"
154	DRAMD16	I/O	"	DRAM Data Bus 16	"
155	Vsso	Vss	-	5 V Gnd	
156	DRAMD17	I/O	Input	DRAM Data Bus 17	PHBTT12, 12mA
157	Vddo	Vdd	-	5 V	
158	DRAMD18	I/O	Input	DRAM Data Bus 18	PHBTT12, 12mA
159	DRAMD19	I/O	"	DRAM Data Bus 19	"
160	DRAMD20	I/O	"	DRAM Data Bus 20	"
161	DRAMD21	I/O	"	DRAM Data Bus 21	"
162	Vssi	Vss	-	3.3 V Gnd	
163	DRAMD22	I/O	Input	DRAM Data Bus 22	PHBTT12, 12mA
164	Vddi	Vdd	-	3.3 V	
165	DRAMD23	I/O	Input	DRAM Data Bus 23	PHBTT12, 12mA
166	DRAMD24	I/O	"	DRAM Data Bus 24	"
167	DRAMD25	I/O	"	DRAM Data Bus 25	"
168	DRAMD26	I/O	"	DRAM Data Bus 26	"
169	Vsso	Vss	-	5 V Gnd	
170	DRAMD27	I/O	Input	DRAM Data Bus 27	PHBTT12, 12mA
171	Vddo	Vdd	-	5 V	
172	DRAMD28	I/O	Input	DRAM Data Bus 28	PHBTT12, 12mA
173	DRAMD29	I/O	"	DRAM Data Bus 29	"
174	DRAMD30	I/O	"	DRAM Data Bus 30	"
175	DRAMD31	I/O	"	DRAM Data Bus 31	"
176	Vsso	Vss	-	5 V Gnd	
177	DRAMA0	O	L	DRAM Address Bus 0	PHOB8, 8 mA
178	DRAMA1	O	"	DRAM Address Bus 1	"
179	DRAMA2	O	"	DRAM Address Bus 2	"
180	DRAMA3	O	"	DRAM Address Bus 3	"

No	Pin Name	I/O	Reset Value	Description	PAD
181	DRAMA4	O	L	DRAM Address Bus 4	PHOB8, 8 mA
182	Vsso	Vss	-	5 V Gnd	
183	DRAMA5	O	"	DRAM Address Bus 5	"
184	DRAMA6	O	"	DRAM Address Bus 6	"
185	DRAMA7	O	"	DRAM Address Bus 7	"
186	Vddo	Vdd	-	5 V	
187	DRAMA8	O	L	DRAM Address Bus 8	PHOB8, 8 mA
188	Vsso	Vss	-	5 V Gnd	
189	DRAMA9	O	L	DRAM Address Bus 9	PHOB8, 8 mA
190	DRAMA10	O	"	DRAM Address Bus 10	"
191	DRAMA11	O	"	DRAM Address Bus 11	"
192	Vssi	Vss	-	3.3 V Gnd	
193	nROMCS0	O	H	ROM Chip Select 0	PHOB4, 4 mA
194	Vddi	Vdd	-	3.3 V	
195	nROMCS1	O	H	ROM Chip Select 1	PHOB4, 4 mA
196	nROMCS2	O	"	ROM Chip Select 2	"
197	nROMCS3	O	"	ROM Chip Select 3	"
198	nROMRD	O	"	ROM or IO Read	PHOB8, 8 mA
199	Vssp	Vss	-	5 V Gnd	
200	nROMWR	O	H	ROM or IO Write	PHOB8, 8 mA
201	Vddp	Vdd	-	5 V	
202	ADDR2	O	L	Address Bus 2 for ROM	PHOB8, 8 mA
203	ADDR3	O	"	Address Bus 3 for ROM	"
204	ADDR4	O	"	Address Bus 4 for ROM	"
205	Vsso	Vss	-	5 V Gnd	
206	ADDR5	O	L	Address Bus 5 for ROM	PHOB8, 8 mA
207	ADDR6	O	"	Address Bus 6 for ROM	"
208	ADDR7	O	"	Address Bus 7 for ROM	"
209	Vssi	Vss	-	3.3 V Gnd	
210	ADDR8	O	L	Address Bus 8 for ROM	PHOB8, 8 mA

No	Pin Name	I/O	Reset Value	Description	PAD
211	ADDR9	O	L	Address Bus 9 for ROM	PHOB8, 8 mA
212	Vddo	Vdd	-	5 V	
213	ADDR10	O	L	Address Bus 10 for ROM	PHOB8, 8 mA
214	Vsso	Vss	-	5 V Gnd	
215	ADDR11	O	L	Address Bus 11 for ROM	PHOB8, 8 mA
216	ADDR12	O	"	Address Bus 12 for ROM	"
217	ADDR13	O	"	Address Bus 13 for ROM	"
218	ADDR14	O	"	Address Bus 14 for ROM	"
219	Vsso	Vss	-	5 V Gnd	
220	ADDR15/CTOut[0]	O	L	Address Bus 15 for ROM	PHOB8, 8 mA
221	ADDR16/CTOut[1]	O	"	Address Bus 16 for ROM	"
222	ADDR17/CTOut[2]	O	"	Address Bus 17 for ROM	"
223	ADDR18/CTOut[3]	O	"	Address Bus 18 for ROM	"
224	Vsso	Vss	-	5 V Gnd	
225	ADDR19/CTOut[4]	O	L	Address Bus 19 for ROM	PHOB8, 8 mA
226	ADDR20/CTOut[5]	O	"	Address Bus 20 for ROM	"
227	ADDR21/CTOut[6]	O	"	Address Bus 21 for ROM	"
228	ADDR22/CTOut[7]	O	"	Address Bus 22 for ROM	"
229	Vddo	Vdd	-	5 V	
230	ADDR23/PTOut	O	L	Address Bus 23 for ROM	PHOB8, 8 mA
231	Vsso	Vss	-	5 V Gnd	
232	TESTSE	I	-	Scan Enable :Tied to Gnd	PHILD50, ST
233	TM	I	-	Test Mode :Tied to Gnd	"
234	Vddi	Vcca	-	3.3 V	for PLL
235	MCLK	I	-	Master Clock	PHIC
236	Vssi	Vssa	-	3.3 V Gnd	for PLL
237	FILTER	O	-	Charge Pump Out : Capacitor is connected	POBA
238	CPUTEST	I	-	CPU Test Mode : Tied to Gnd	PHILD50, ST
239	nRESET	I	-	Reset Input	PHIL, ST
240	nRSTOUT	O	L	Reset Output	PHOB8, 8 mA

### 3-2-4 PROGRAM ROM (FLASH MEMORY) CONTROL

#### 1) DEVICE

TYPE No.....AM29F800B  
 CAPACITY.....4 MBYTE (512K \* 16BITS \* 4)

#### 2) PROGRAMMING

BEFORE ASS'Y .....EPROM PROGRAMMER or PROGRAMMING at the factory  
 AFTER ASS'Y .....DOWNLOAD from PC

#### 3) OPERATING PRINCIPLE

When the RCSO(ROM CHIP SELECT)signal is activated from the CPU after the POWER is ON, it activates RD SIGNAL and reads the DATA(HIGH/LOW) stored in the FLASH MEMORY to control the overall system.  
 The FLASH MEMORY may also write. When turning the power on, press and hold the key(power switch) for 2 - 3 seconds, then the LED will scroll and the PROGRAM DOWNLOAD MODE will be activated. In this mode, you can download the program through the parallel port.

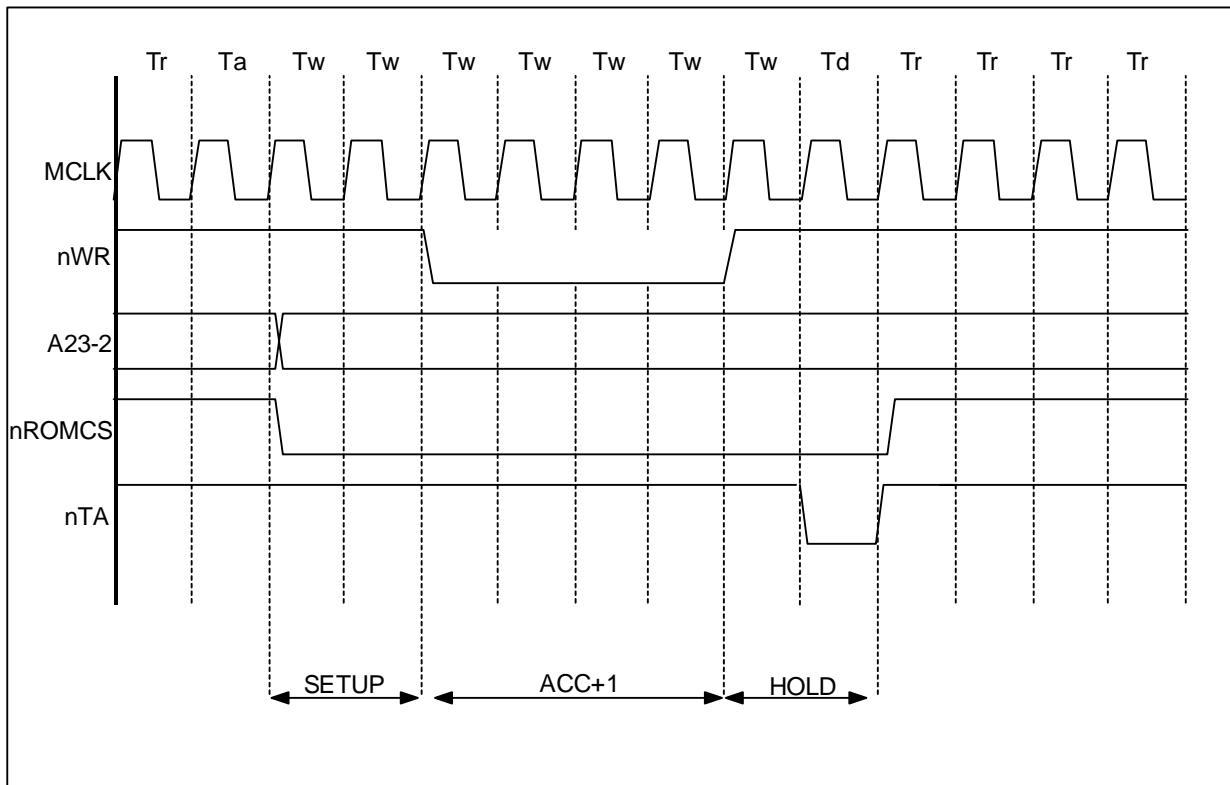

<Write Timing Diagram for Two Beat Burst Cycle>

### 3-2-5 DRAM CONTROL

#### 1) DEVICE

TYPE NO.....K4E6411D EDO TYPE  
 CAPACITY.....4MBYTES (1M\*16BITS\*2)

#### 2) OPERATING PRINCIPLE

DRAM can either read or write. The data can be stored in the DRAM only when the power is on. It stores data while the CPU processes data. The address to read and write the data is specified by RAS SIGNAL and CAS SIGNAL. DRAMWE\* SIGNAL is activated when writing data and DRAMOE\* SIGNAL, when reading. You can expand up to 64MBYTE of DRAM in this system.

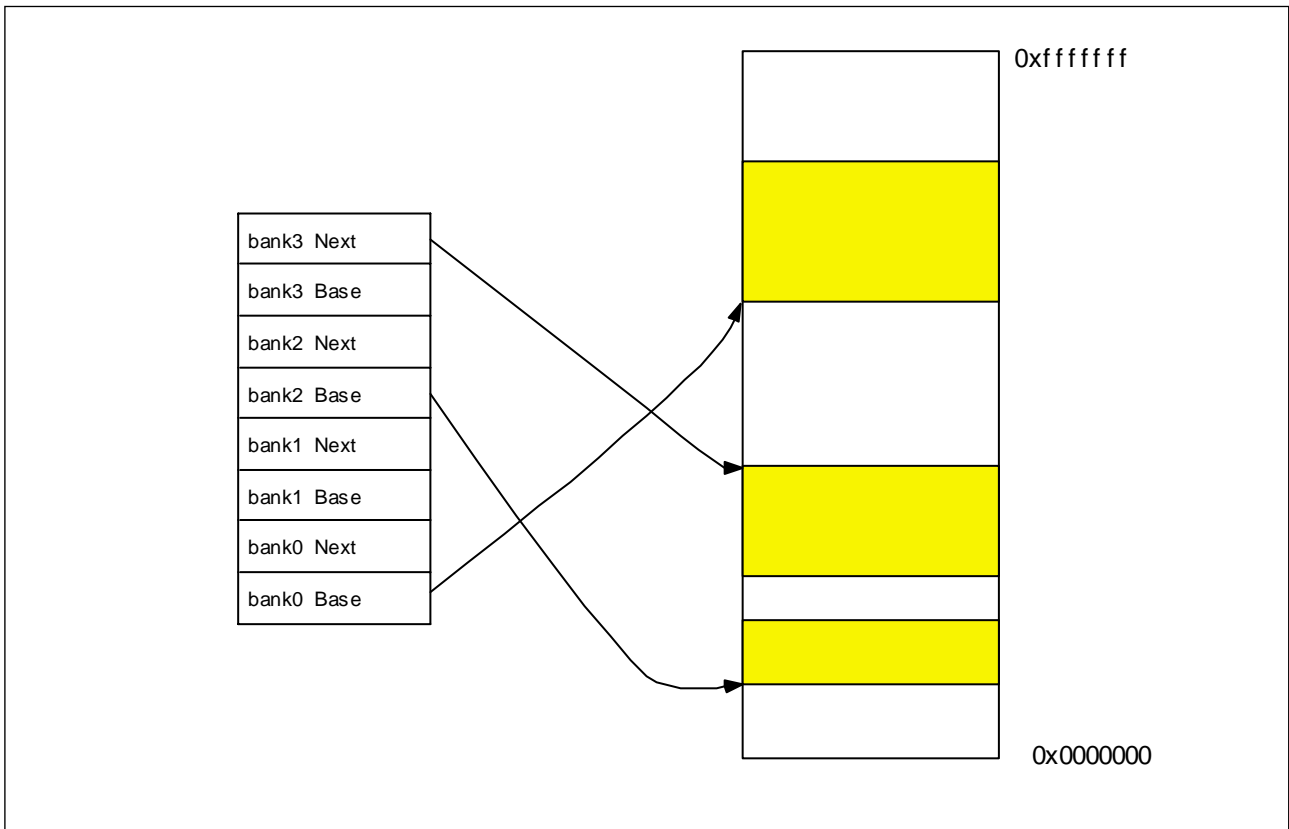

<DRAM Bank Configuration>

### 3-2-5-1 Fpm DRAM reading Timing

Fast Page Mode DRAM can access the page mode. It can read consecutive cells by accessing the page mode while accessing the burst. For FPM DRAM, the data are valid only when the nCAS is active.

While configuring the software, you must set the timing register of SFR considering the clock speed and the DRAM spec.

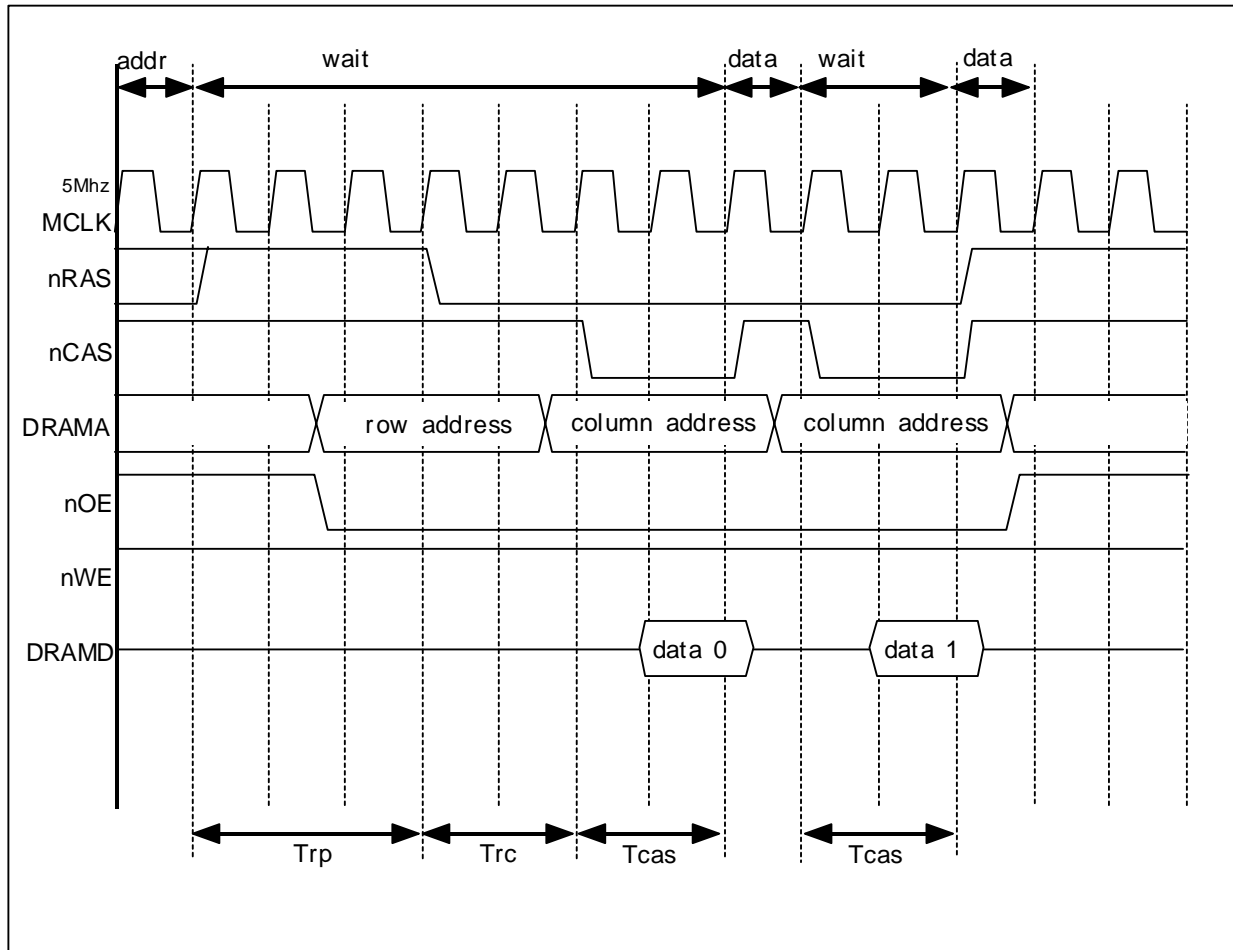

<FPM Read Timing Diagram>

3-2-5-2 fpm DRAM write timing

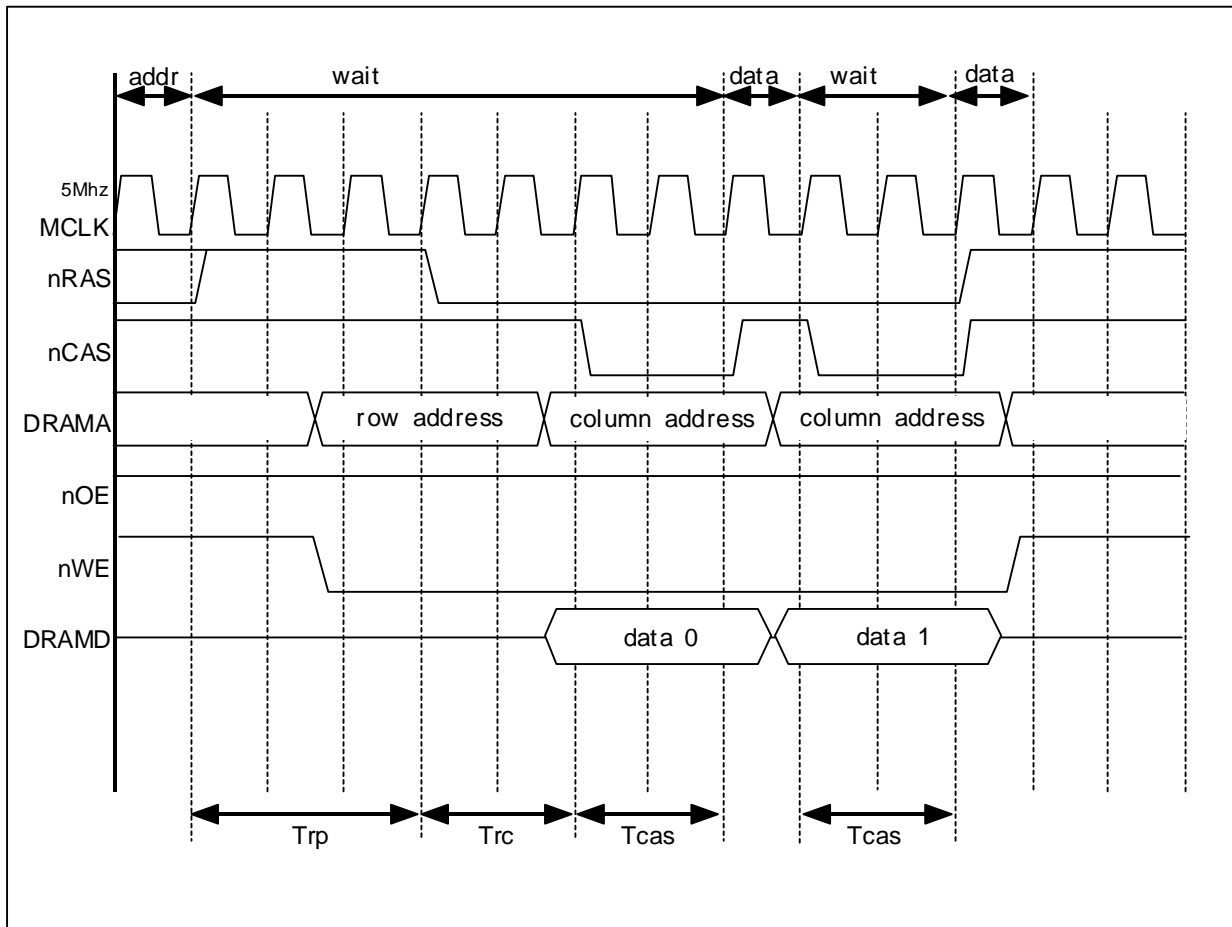

<FPM Write Timing Diagram>

clock	type	Trp		Trc		Tcas	
		cycle #	register	cycle #	register	cycle #	register
58MHz	40 ns FPM	2	0x1	2	0x1	1	0x0
	50 ns FPM	2	0x1	2	0x1	1	0x0
	60 ns FPM	3	0x2	2	0x1	2	0x1
	70 ns FPM	3	0x2	2	0x1	2	0x1

<SFR Values Example for FPM>

### 3-2-5-3 EDO DRAM read timing

Basically the Extended Data Out DRAM is similar to Fast Page Mode DRAM. For FPM, the data are valid only when the nCAS is active while reading the internal data, however, it has a latch that the data will be continuously outputted even after the nCAS is inactivated.

While configuring the software, you must set the timing register of SFR considering the clock speed and the DRAM spec.

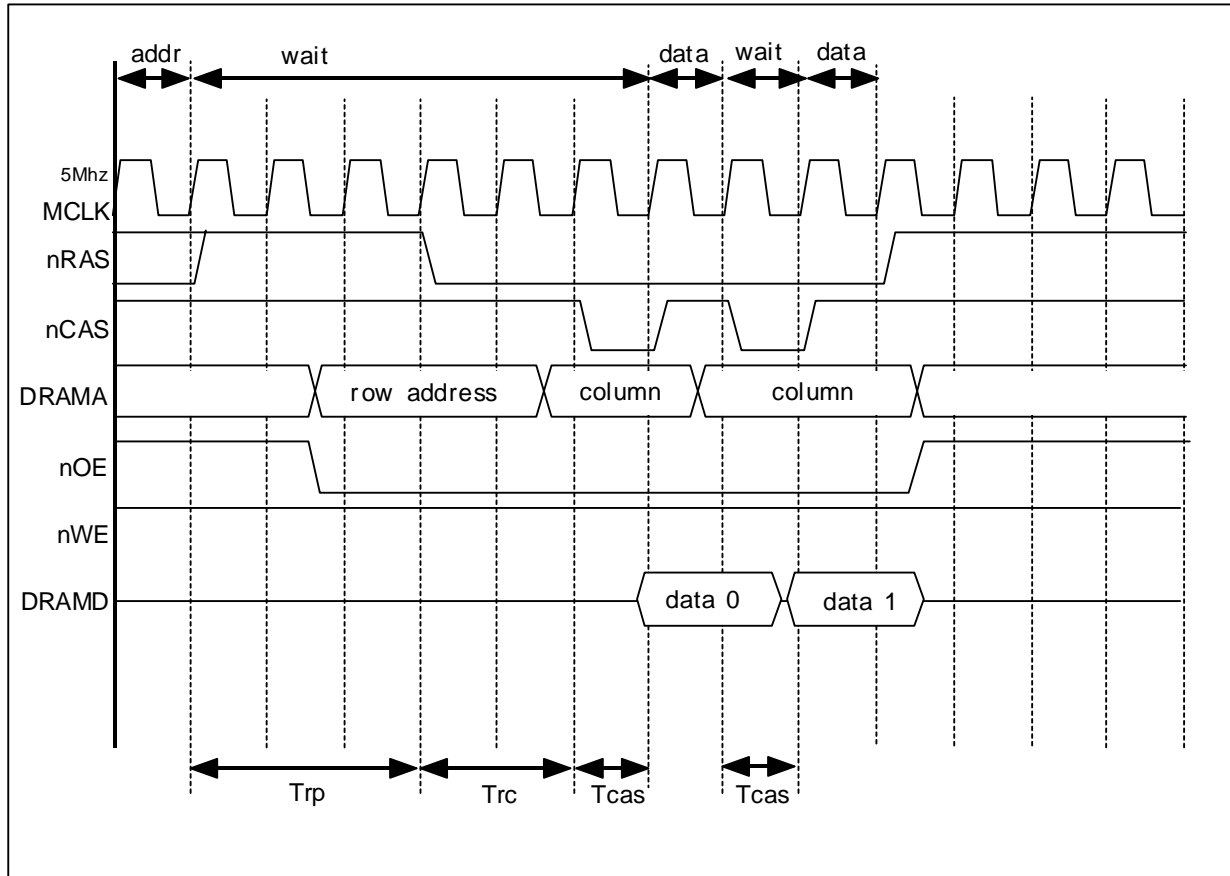

<EDO Read Timing Diagram>

3-2-5-4 edo DRAM write timing

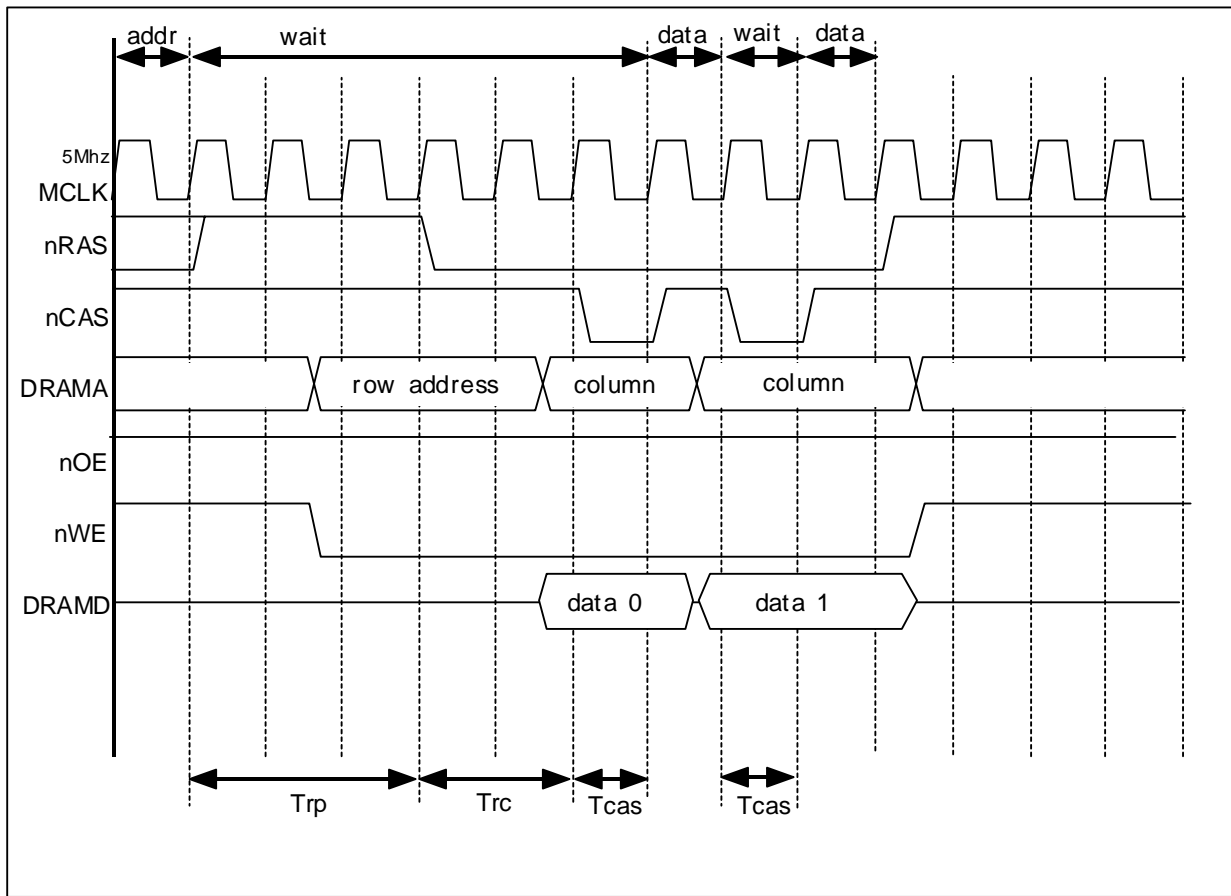

<FPM Write Timing Diagram>

clock	type	Trp		Trc		Tcas	
		cycle #	register	cycle #	register	cycle #	register
58Mhz	40 ns EDO	2	0x1	2	0x1	1	0x0
	50 ns EDO	2	0x1	2	0x1	1	0x0
	60 ns EDO	3	0x2	2	0x1	1	0x0
	70 ns EDO	3	0x2	2	0x1	2	0x1

<SFR Values Example for FPM>

### 3-2-6 FS781 (FREQUENCY ATTENUATOR)

This system used FS781 for the main clock for EMI SUPPRESSION.

It spreads the source clock in a consistent bandwidth to disperse the energy gathered in order to attenuate the energy.

The capacitor value of the loop filter(PIN 4) is set depending on the source clock used or the spread bandwidth. Refer to FS781 Spec. for detail.

### 3-2-7 USB (UNIVERSAL SERIAL BUS)

NS's USBN9602 is used as the interface IC and 48MHz clock is used.

When the data is received through the USB port, EIRQ1 SIGNAL is activated to send interrupt to CPU, then it directly sends the data to DRAM by IOCS4\*&DRAMA(11) SIGNAL through DRAMD (24;31).

### 3-2-8 SRAM; 32KB SRAM

It stores a variety of option data.

### 3-2-9 FAX TRANSCIEVER

#### 3-2-9-1. GENERAL

This circuit processes transmission signals of modem and between LIU and modem.

#### 3-2-9-2. MODEM (U39)

FM336 is a single ship fax modem. It has functions of DTMF detection and DTMF signal production as well as functions of modem. TX A1, 2 is transmission output port and RX IN is received data input port. / POR signal controlled by MFP controller (U36:KS32C61200) can initialize modem (nMODEM\_RST) without turning off the system.

D0-D7 are 8-bit data buses. RS0-RS4 signals to select the register in modem chips. /RS and /WR signals control READ and WRITE respectively. /IRQ is a signal for modem interrupt.

Transmission speed of FM336 is supported up to 33.6k. The modem is connected to LINE through transformer directly.

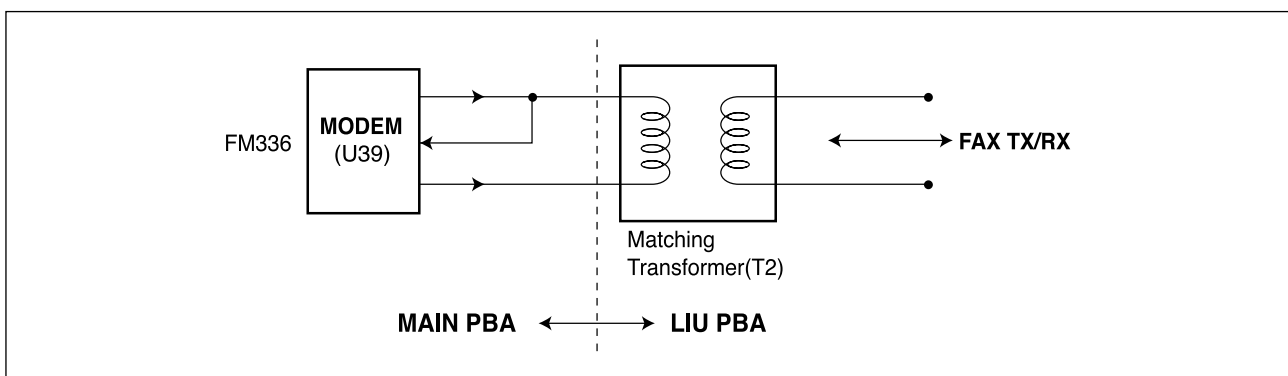

< FAX TRANSCIEVER >

### 3-2-10 PM-22 (JBIG COMPRESS & DECOMPRESS)

#### 3-2-10-1 Block Diagram

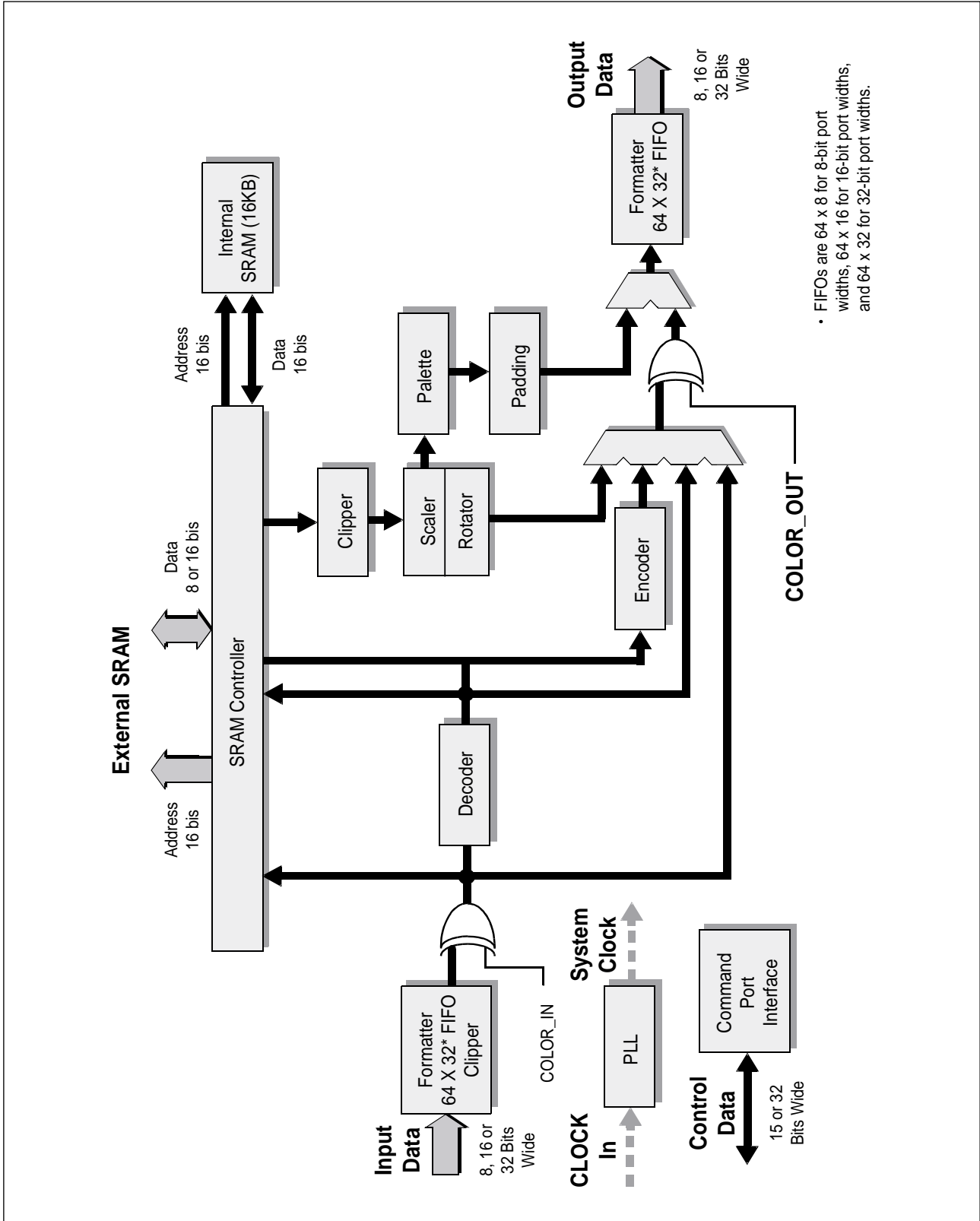

### 3-2-10-2 Specifications

This section presents the electrical and environmental specifications of the PM-22.

#### 1) Power Ratings

Table presents the PM-22's minimum and maximum power ratings and storage temperatures.

Parameter	Symbol	Min	Max	Units	
3.3 Volts Supply Voltage	<b>VDD</b>	-0.3	7.0	Volts	
5.0_Volt Reference Level*	3.3_Volt Oper.	<b>VDDBIAS</b>	VDD	3.6	Volts
	5.0_Volt Oper.	<b>VDDBIAS</b>	VDD	5.55	Volts
Input pin voltages for other than <b>VDD</b> , <b>VSS</b>	Vin	-0.3	<b>VDDBIAS + 0.3</b>	Volts	
DC Input Current	Iin	-10	+10	mAmps	
Storage Temperature	Tas	-40	125	Degrees C	

\* VDDBIAS is connected to the system's 5.0V supply to provide 5V tolerance on I/O signal pins (including all inputs, outputs, and bidirectionals). in systems where 3.3V signaling only is used, connect VDDBIAS to a 3.3V supply.

#### 2) Required Operation Conditions

Table presents the PM-22's environmental specifications.

Parameter	Symbol	Min	Max	Units
3.3 Volts Supply Voltage	<b>VDD</b>	3.0	3.6	Volts
5.0_Volt Reference Level*	<b>VDDBIAS</b>	4.75	5.25	Volts
Power Consumption at 66 MHz Operation	Pd	-	1.0	Watt
Operating Temperature	Tao	0	70	Degrees C

\* VDDBIAS is connected to the system's 5.0V supply to provide 5V tolerance on I/O signal pins (including all inputs, outputs, and bidirectionals). in systems where 3.3V signaling only is used, connect VDDBIAS to a 3.3V supply.

### 3-2-10-3 Electrical Specifications

This section provides the PM-22's electrical specifications.

Parameter	Symbol	Min	Max	Units
Input capacitance for all input only pins	Cin	0	10	pF
Input capacitance for all bidirectional pins	Cio	0	15	pF
Input high voltage for all inputs	Vin	2.0	<b>VDDBIAS</b> +0.3	Volts
Input low voltage for all inputs	Vil	<b>GND</b> -0.3	0.8	Volts
Output high voltage for all outputs	Voh	2.4	<b>VDD</b>	Volts
Output low voltage for all outputs	Vol	<b>GND</b>	0.4	Volts
Input current with input at <b>VDD</b>	Iih	-30	30	μA
Input current with input at <b>GND</b>	Iil	-30	30	μA
Tri-state output current with output at <b>VDD</b>	Iozh	-100	100	μA
Tri-state output current with output at <b>GND</b>	Iozl	-100	100	μA
Power supply current	Icc	0	95	mA

< DC Characteristics >

#### **DC Characteristics**

Table presents the PM-22's DC characteristics.

**IMPORTANT** : CLOCK pin timing is measured at TTL levels, not CMOS. The system CLOCK driver must be configured correctly in order to ensure that duty cycle and Vil specifications are met.

### 3-2-10-4 Pin Classification and Loading

Table describes the pin classification and loading of the PM-22 signal pins. The capacitance column presents the values used to derive the specification timing. The current columns present maximum values. Table uses the following notation for pin types :

Name	Pins	Level	Resistor	Type	Abbreviation/Description	Maximum Loading		
						Cap.	Current(mA)	
						(pF)	Vol	Voh
AGND		L	~	P	Analog Supply Return (Gnd.)	~	~	~
AVDD		H	~	P	Analog Power Supply Source	~	~	~
ALD[7:0]	8	H	H	1/3S	Alternate Data Output	50	4	4
CD[15:0]	16	H	H	1/3S	Command Data	50	8	8
CLOCK	1	H	~	I	System Clock	~	~	~
CLK_OUT	1	H	~	3S	PLL Clock Test Output			
$\overline{\text{CS}}$	1	L	~	I	System Clock	~	~	~
DONE	1	H	~	O	Operation Done Flag	50	8	8
GND	23	N/A	~	P	Supply Return (Gnd.)	~	~	~
$\overline{\text{IBACK}}$	1	L	~	I	Input Burst Active	~	~	~
I/D	1	H	~	I	Index/Data Control	~	~	~
ID[15:0]	16	H	~	1/3S	Input Data	~	~	~
$\overline{\text{IDACK}}$	1	L	~	I	Input Data Strobe	~	~	~
IDREQ	1	H	~	3S	Input Data Request	50	8	8
IFRDY	1	H	~	I	Input Buffer Ready	~	~	~
$\overline{\text{IN\_OVR}}$	1	L	H	I	Buffer Overflow Alert	~	~	~
$\overline{\text{INT}}$	1	L	~	OD	Interrupt Request	50	8	8
$\overline{\text{ISTRB}}$	1	L	~	O	Input Buffer Strobe	50	4	4
LSYNC	1	H	~	O	Input Data Sync	50	4	4
NC	4	~	~	~	No Connect	~	~	~
$\overline{\text{OBACK}}$	1	L	H	I	Output Burst Active	~	~	~
OD[15:0]	16	H	~	1/3S	Output Data	50	8	8
$\overline{\text{ODACK}}$	1	L	H	I	Output Data Strobe	~	~	~
ODREQ	1	H	~	3S	Output Data Request	50	8	8
OFRDY	1	H	~	I	Output Buffer Ready	~	~	~
$\overline{\text{OSTRB}}$	1	L	~	O	Output Buffer Strobe	50	4	4
PLL_BYP	1	H	~	I	Phase Locked Loop Bypass	~	~	~
RA[15:0]	16	H	~	O	RAM Address	50	4	4
$\overline{\text{RAMOE}}$	1	L	~	O	RAM Output Enable	50	4	4

< Pin Classification and Loading >

Name	Pins	Level	Resistor	Type	Abbreviation/Description	Maximum Loading		
						Cap.	Current(mA)	
						(pF)	Vol	Voh
$\overline{\text{RAMWR}}$	1	L	~	I	RAM Write Enable	50	4	4
$\overline{\text{RD}}$	1	L	~	I	Command Port Read	~	~	~
RD [7:0]	8	H	H	1/3S	RAM Data	50	4	4
$\overline{\text{RE}}$ [1:0]	2	L	~	O	RAM Enable	50	4	4
$\overline{\text{RESET}}$	1	L	H	I	Chip Reset	~	~	~
TESTIN	1	H	~	I	Test Input	~	~	~
TESTOUT	1	H		O	Manufacturing Test Output	~	~	~
VDD	22	N/A	~	P	Power Supply Source	~	~	~
VDDBIAS	1	N/A			Input Reference Voltage			
$\overline{\text{WR}}$	1	L	~	I	Command Port Write	~	~	~

< Pin Classification and Loading >

- I : Input
- O : Output
- 3S : Tri-state output
- OD : Open drain output
- P : Power supply

Combinations indicate bidirectional pins.

An "H" in the Resistor column indicates the pad has an internal pull-up resistor. A tilde (~) indicates no internal resistor.

## 3-3 Scanner

### 3-3-1 SUMMARY

This device to read manuscripts has 300 dpi CIS as an image sensor.

**CIS** : Contact Image Sensor

**This machine uses a color CIS.**

- Minimum Scan Line Time for One Color : 1.2 mS
- Light Source Power : +12 V
- Maximum Pixel frequency : 1.17 MHz
- Effective Sensor Element : 2574
- Clamp Level : 1.4 V
- Bright Output : 2.6 V

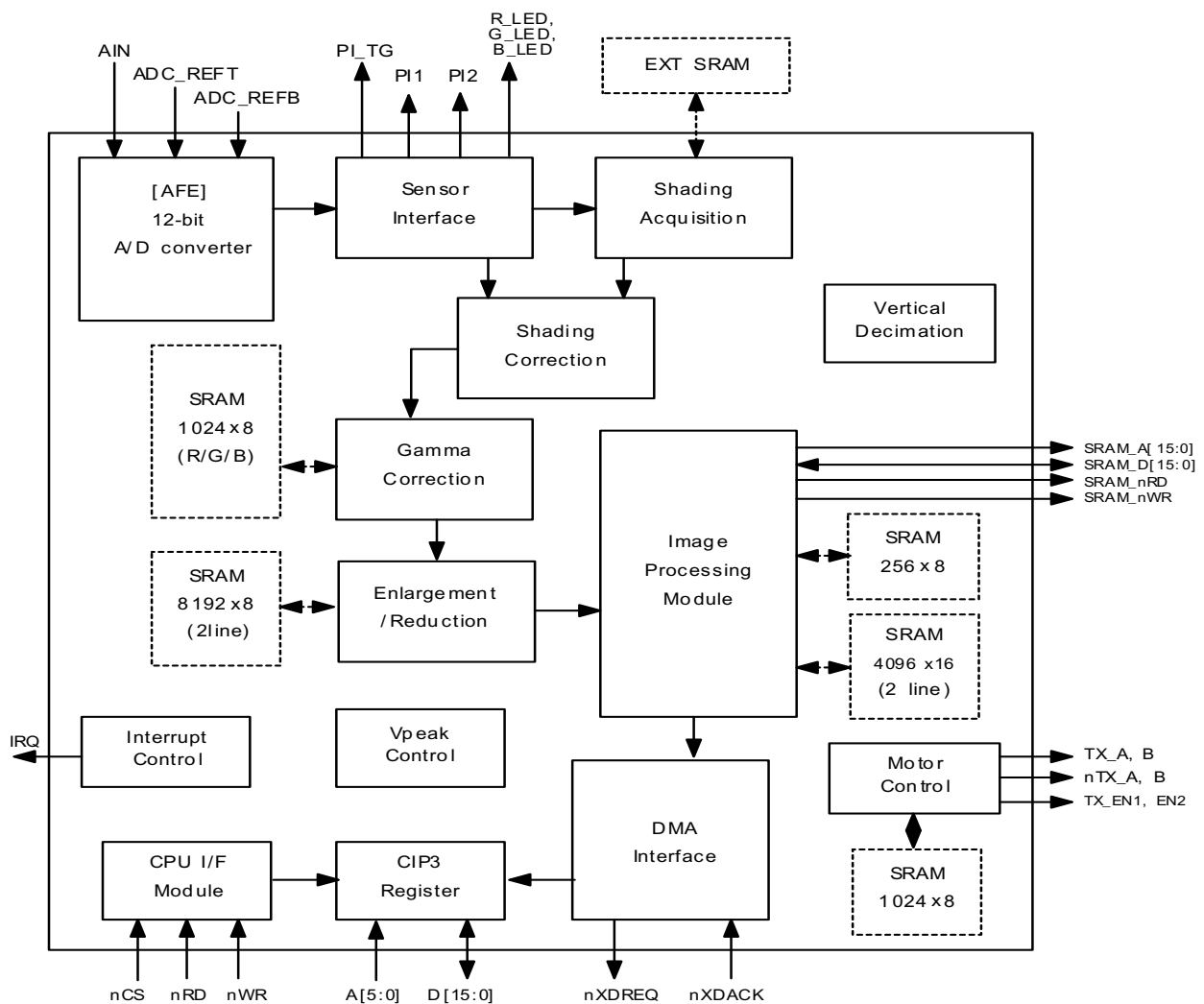

<Block Diagram>

## 3-3-2 KEY FEATURES

### Overview

- (1) 0.5µm C-MOS process(TLM), 208-PIN QFP, STD85 library
- (2) Frequency : 50 MHz
- (3) On-Chip oscillator
- (4) Method : Raster scanning method
- (5) Image Sauce : 300 dpi CIS
- (6) Scanning Mode
  - color gray image : each 8 bits / RGB
  - mono gray image : 8 bits / pixel
  - binary image : 1 bit / pixel (for text/photo/mixed mode)
- (7) Maximum scanning width : A4, 300 dpi
- (8) A/D conversion depth : 12bits

### Pixel processing structure

- Minimum pixel processing time : 4 system clocks
  - High speed pipelined processing method
- (Shading correction, Gamma correction, Enlargement/Reducement, and Binarization)

### Shading Correction

- (1) White shading correction support for each R/G/B
- (2) White shading data memory : 3x8Kx12bits = 288Kbits      384Kbits (external)
- (3) Black shading data memory : 3x8Kx12bits = 288Kbits      384Kbits (external)

### Gamma Correction

- (1) Independent Gamma table for each RGB component
- (2) Gamma table data memory : 3x1Kx8bits = 24Kbits (internal)

### Binarization (mono)

- (1) 256 Gray's halftone representation for Photo document : 3x5 EDF(Error Diffusion) method proposed by Stuck.
- (2) LAT(Local Adaptive Thresholding) for Text document :
  - use of 5x5 LOCAL WINDOW (TIP ALGORITHM)
  - ABC(Automatic Background Control) :Tmin Automatic change
- (3) Mixed mode processing for text/photo mixed document
- (4) EDF data memory : 2x4Kx16bits = 128Kbits (internal)
- (5) LAT data memory : 4x4Kx16bits = 256Kbits (external)

### Scaling of input image

- (1) Scaling factor
  - Horizontal direction : 25 ~ 800% by 1% unit
  - Vertical direction : 25 ~ 100% by 1% unit
- (2) Scaling data memory : 2x8Kx8bits = 128Kbits (internal)

**Intelligent scan motor controller**

- (1) Automatic acceleration/deceleration/uniform velocity
- (2) Data memory : 256x16bits = 4Kbits (internal)

**Auto-Run**

Automatic CLK\_LINE (line processing start control) and \*TG (line scan start control) signal generation|

- (1) Available resynchronization of øTG signal
- (2) programmable øTG's period & CLK\_LINE's occurrence number

**Processed data output format in DTM(Data Transfer Module)**

- (1) DMA mode : Burst/On-demand mode
- (2) CDIP I/F : LINE\_SYNC, PIXEL\_SYSNC, PIXEL\_DATA[7:0]

- 36 General Purpose Input/Output : 8(GPO), 28(GPIO)
- Black/White reversion, and Image Mirroring support

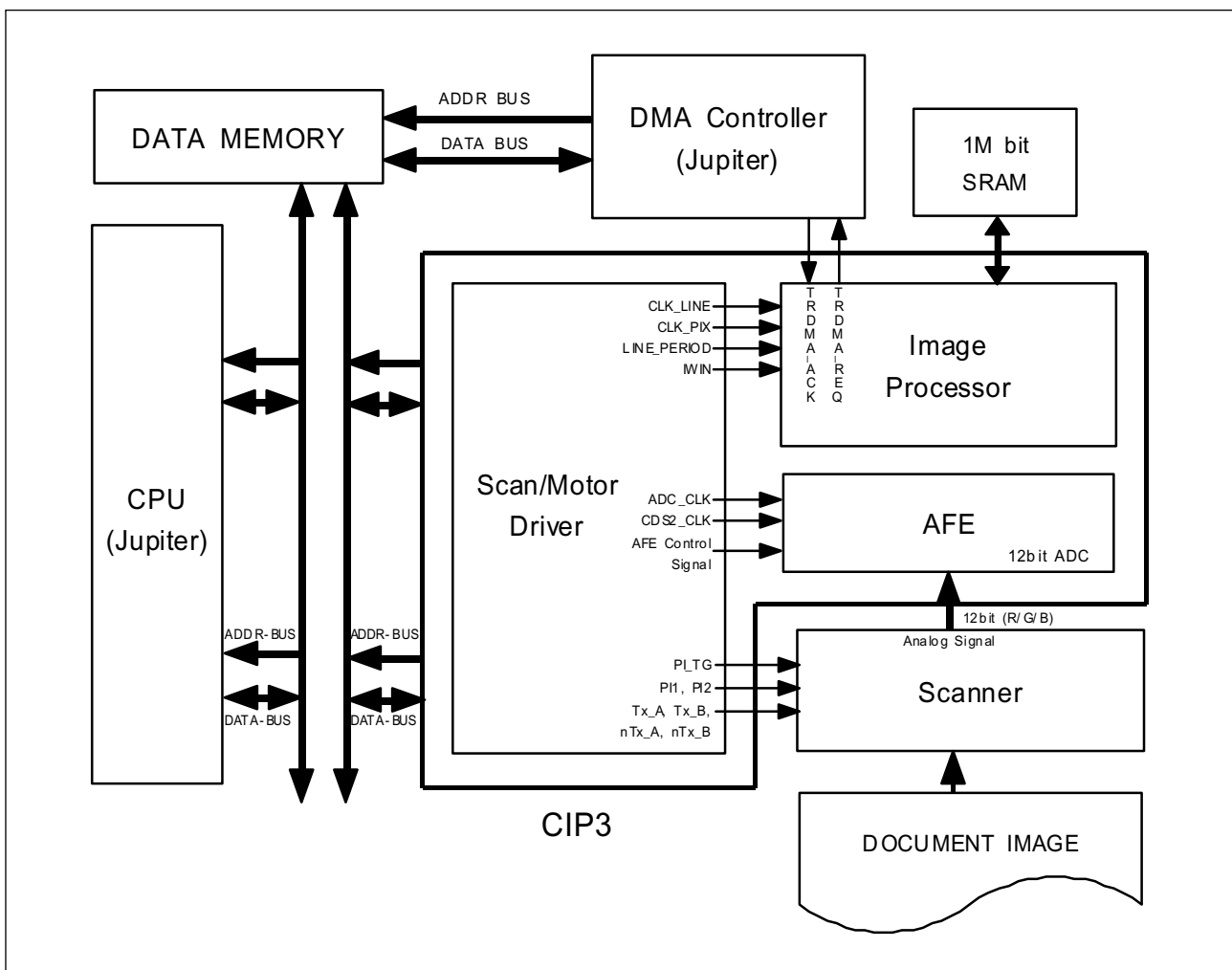

<External interface with CIP3>

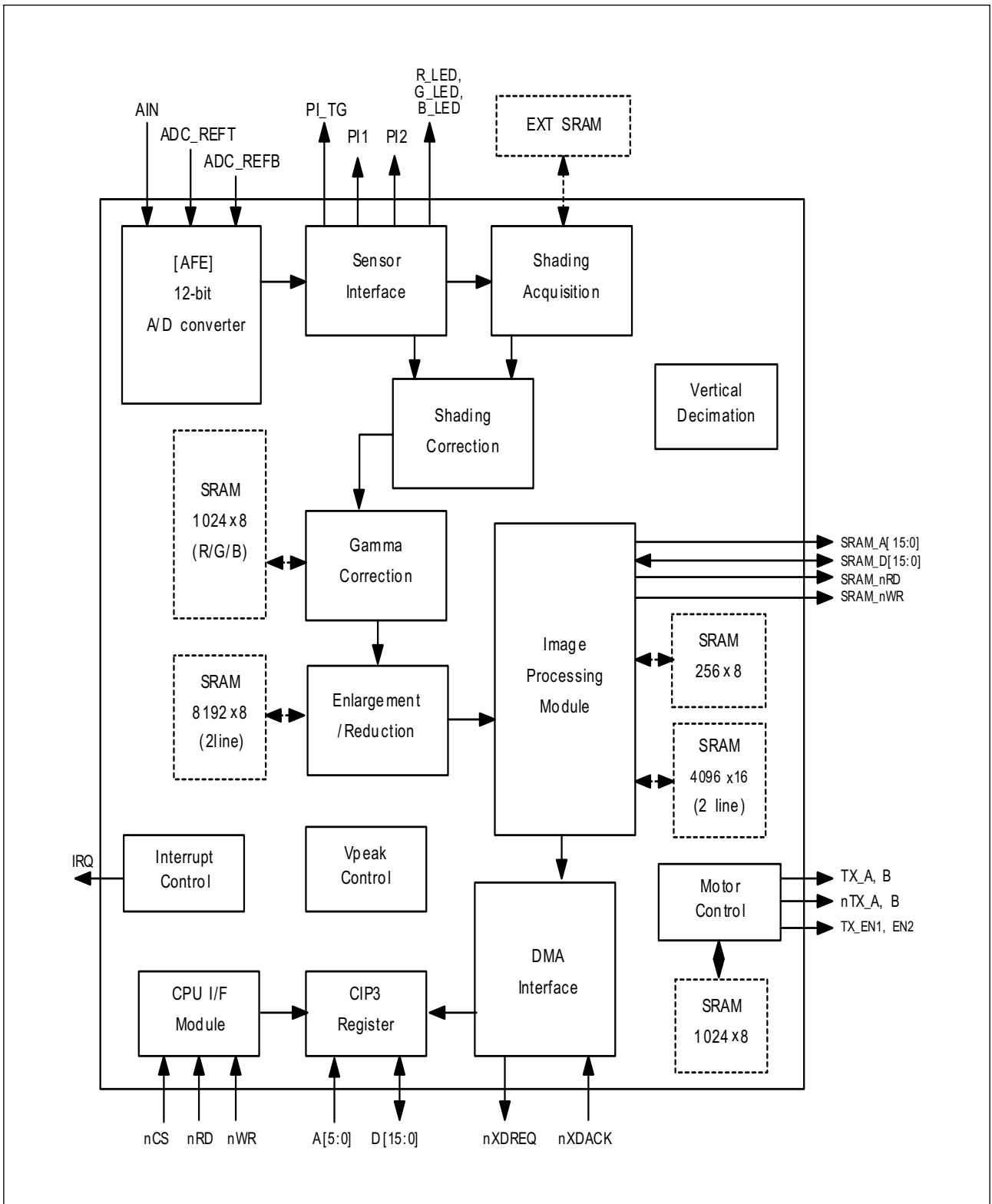

<Block diagram of CIP3>

## 3-4 HOST INTERFACE:

Referred to IEEE 1284 standard.

### 3-4-1. HOST INTERFACE

PARALLEL PORT INTERFACE PART KS32C61200 has the Parallel Port Interface Part that enables Parallel Interface with PC. This part is connected to PC through Centronics connector.

It generates major control signals that are used to actuate parallel communication. It is comprised of /ERROR, PE, BUSY, /ACK, SLCT, /INIT, /SLCTIN, /AUTOFD and /STB.

This part and the PC data transmission method support the method specified in IEEE P1283 Parallel Port Standard (<http://www.fapo.com/ieee1284.html>).

In other words, it supports both compatibility mode (basic print data transmitting method), the nibble mode (4bit data; supports data uploading to PC) and ECP (enhanced capabilities port: 8bits data - high speed two-way data transmission with PC). Compatibility mode is generally referred to as the Centronics mode and this is the protocol used by most PC to transmit data to the printer. ECP mode is an improved protocol for the communication between PC and peripherals such as printer and scanner, and it provides high speed two-way data communication. ECP mode provides two cycles in the two-way data transmission; data cycle and command cycle.

The command cycle has two formats; Run-Length Count and Channel Addressing. RLE (Run-Length Count) has high compression rate (64x) and it allows real-time data compression that it is useful for the printer and scanner that need to transmit large raster image that has a series of same data. Channel Addressing was designed to address multiple devices with single structure.

For example, like this system, when the fax/printer/scanner have one structure, the parallel port can be used for other purposes while the printer image is being processed. This system uses RLE for high speed data transmission.

PC control signals and data send/receive tasks such as PC data printing, high speed uploading of scanned data to PC, upload/download of the fax data to send or receive and monitoring the system control signal and overall system from PC are all processed through this part.

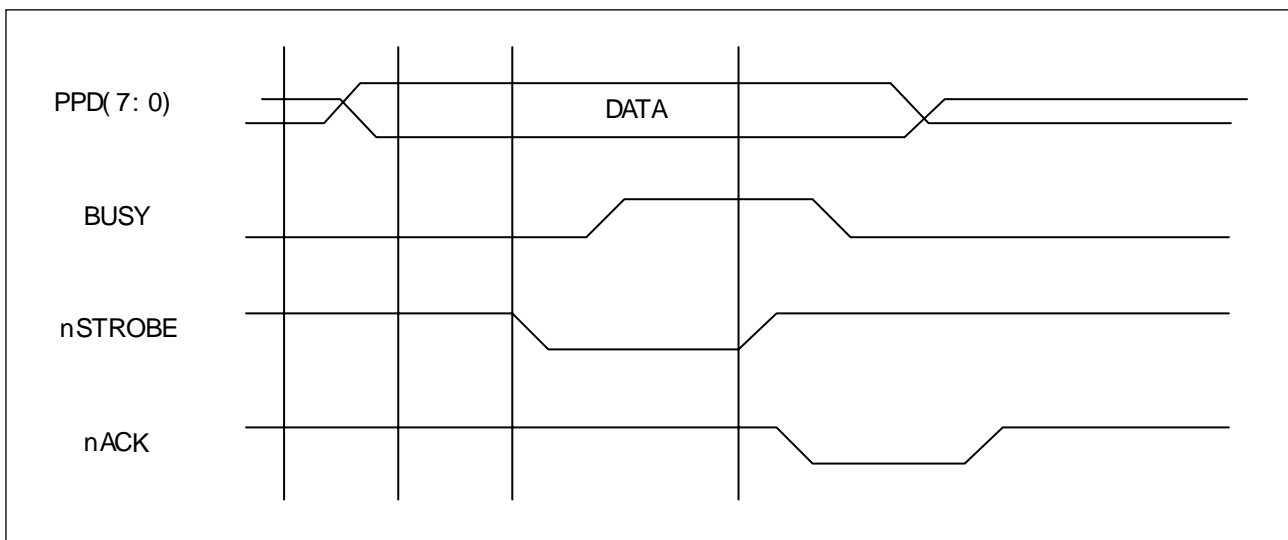

<Compatibility Hardware Handshaking Timing>

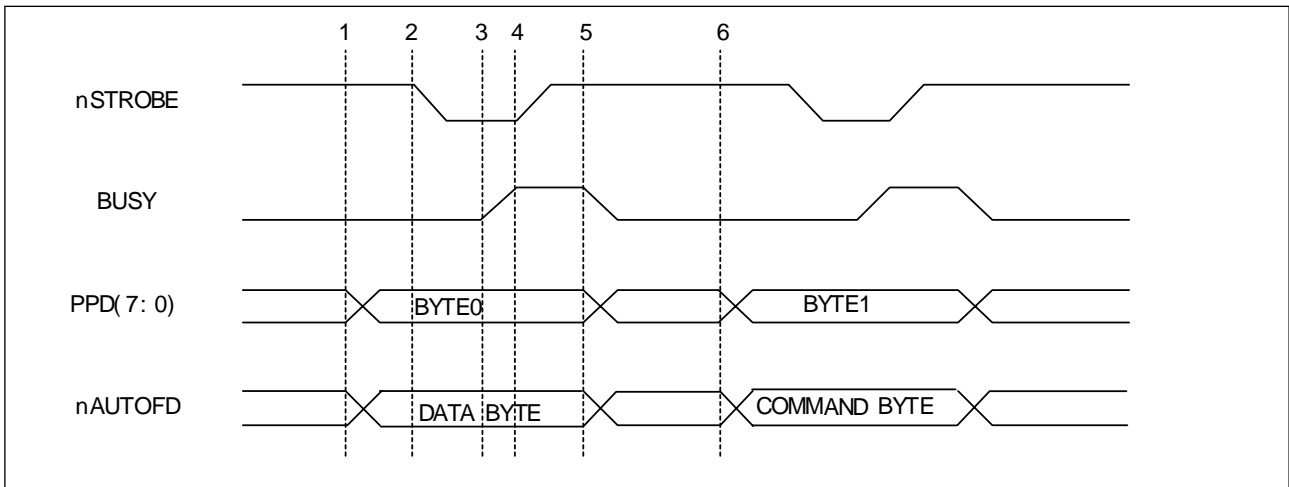

<ECP Hardware Handshaking Timing (forward) >

1. The host places data on the data lines and indicates a data cycle by setting nAUTOFD
2. Host asserts nSTROBE low to indicate valid data
3. Peripheral acknowledges host by setting BUSY high
4. Host sets nSTROBE high. This is the edge that should be used to clock the data into the Peripheral
5. Peripheral sets BUSY low to indicate that it is ready for the next byte
6. The cycle repeats, but this time it is a command cycle because nAUTOFD is low

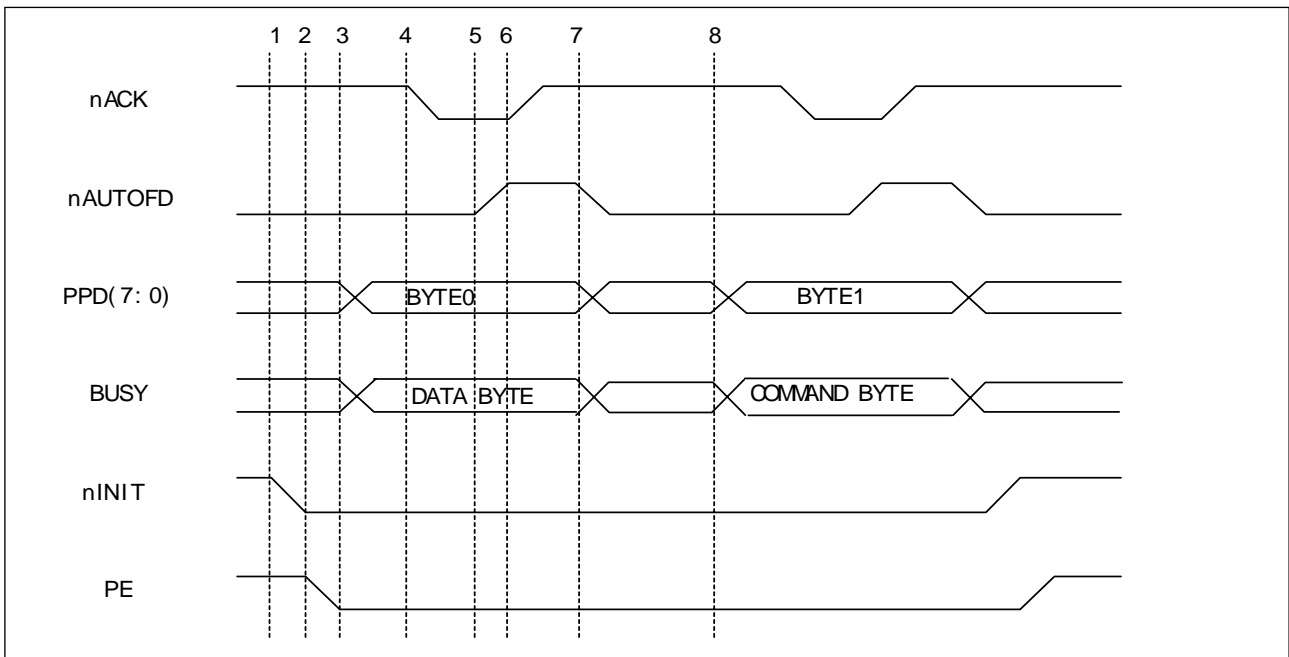

<ECP Hardware Handshaking Timing (forward) >

1. The host request a reverse channel transfer by setting nINIT low
2. The peripheral signals that it is OK to proceed by setting PE low
3. The peripheral places data on the data lines and indicates a data cycle by setting BUSY high
4. Peripheral asserts nACK low to indicate valid data
5. Host acknowledges by setting nAUTOFD high
6. Peripheral sets nACK high. This is the edge that should be used to clock the data into the host
7. Host sets nAUTOFD low to indicate that it is ready for the next byte
8. The cycle repeats, but this time it is a command cycle because BUSY is low

### 3-4-2 USB INTERFACE

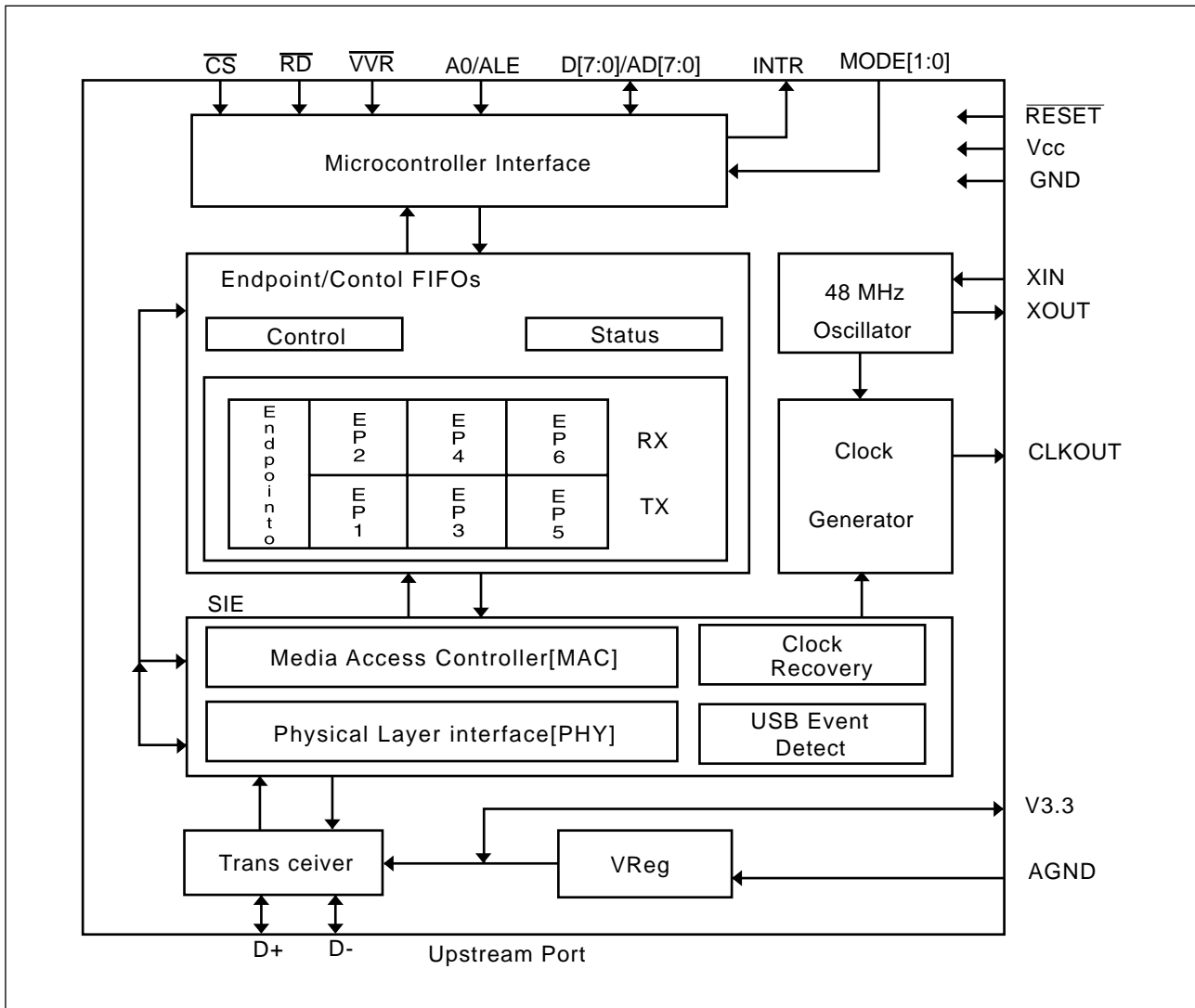

#### 3-4-2-1 Features

- Full-Speed USB Node Device
- USB transceiver
- 3.3V signal voltage regulator
- 48 MHz oscillator circuit
- Programmable clock generator
- Serial Interface Engine consisting of Physical Layer Interface (PHY) and Media Access Controller (MAC), USB Specification 1.0 compliant
- Control/Status Register File
- USB Function Controller with seven FIFO-based End-points :
  - One bidirectional Control Endpoint 0 (8bytes) : Three Transmit Endpoints (2\*32 and 1\*64 bytes)
  - Three Receive Endpoints (2\*32 and 1\*64 bytes)
- 8-bit parallel interface with two selectable modes : non-multiplexed
- multiplexed (Intel compatible)
- DMA support for parallel interface
- MICROWIRE/PLUS Interface
- 28-pin SO package



## 3-5 Engine Controller

### 3-5-1. FUSER CONTROL / THERMISTOR CIRCUIT

This circuit controls the heat lamp temperature to fix the transferred toner on the paper. It is comprised of the thermistor that has the negative resistance against the temperature and LM393 (voltage comparator) and transistor for switching. The thermistor has the resistance value reverse proportional to the heat lamp surface temperature. The voltage value is read by #60 pin(AVIN2) of CPU referring to the parallel combined resistance with the resistor(R43) connected parallel to it and the voltage distribution of R29. The voltage read activates (inactivates) 'fuser' signal to high (or low) referring to the set temperature and when the 'fuseron' signal turns down(high) to low(high) by Q3 switching, the S21ME4 inside SMPS (PC3) turns on(off) and this eventually turns two-way thyristor(THY501) on(off) to allow(shut) AC voltage to the heat lamp.

LM393 is a H/W designed to protect the system when the software heat lamp control does not run normal. When the thermistor temperature goes up to 210°C, #1 pin's level (LM393) will turn low to turn the 'fuseron' signal to high. (forcefully shuts off Q3)In other words LM393 shuts off the heat lamp forcefully.

### 3-5-2. PAPER SENSING CIRCUIT

#### 1) Cover Open Sensing

Cover Open Sensor is located on the right rear side of the printer. In case the right cover is open, it shuts +5V (LSU laser unit) and +24V( polygon motor of fixer LSU and HVPS) that are supplied to each unit. It detects the cover opening through CPU. In this case, the red LED of the OP Panel LED will turn on.

#### 2) Paper Empty Sensing

The paper empty sensor (photo interrupter), located inside bottom of the bin cassette detects paper with the actuator connected to it and informs the CPU of whether there is paper. When there is no paper in the cassette, the red LED of the OP panel LED will turn on to tell the user to fill the cassette with papers.

3) Paper Feeding When the paper is fed into the set and passes through the actuator of the feed sensor unit, transistor inside the photo interrupter will turn on, 'nFEED' signal will turn low and inform CPU that the paper is currently fed into the system. CPU detects this signal and sprays video data after certain time (related to paper adjustment). If the paper does not hit the feed sensor within certain time, CPU detects this and informs as "Paper Jam0" (red LED on the OP panel will turn on).

#### 4) Paper Exit Sensing

The system detects the paper going out of the set with the exit sensor assembled to the actuator attached to the frame. If CPU does not turn back high a while after the paper hits the exit sensor, CPU detects this and inform as "Paper Jam2" (red LEDs on the OP panel will turn on).

### 3-5-3. LSU CIRCUIT

#### 1) Polygon Motor Unit (actuated by +24V)

The polygon motor inside LSU rotates by the 'PMOTOR' signal. When it reaches the motor constant velocity section through the initial transient (transient response) section, it sends the 'nLREADY' signal to the CPU. The 'clock' pin is the pin that receives clock of the required frequency when LSU uses external CLK as the motor rotational frequency. Currently the external clock circuit is located in the HVPS and 1686Hz = 6.9083MHz (crystal frequency)-4096(74HC4060N IC), is used as the rotational frequency of the polygon motor.

#### 2) Laser Unit (actuated by +5V)

After laser is turned on by 'nLD\_ON' signal, it is reflected by 6 mirrors (polygon mirror) attached to the polygon motor and performs scan in horizontal way. When the laser beam hits the corner of the polygon mirror, it generates 'nHSYNC' signal (pulse) and the CPU forms the left margin of the image using this signal (horizontal synchronous signal).

### 3-5-4. FAN/SOLENOID ACTUATION CIRCUIT

The fan actuation circuit its power using NPN TR. When it receives 'FAN' signal from the CPU. The TR will turn on to make the voltage supplied to the fan to 24V in order to actuate the fan.

The solenoid is actuated in the same way. When it receives control signal from the CPU, the solenoid for paper feeding is actuated by switching circuit.

D6, D2, D20 and D16(1N4003) diode is applied to the both ends of the output terminal to protect TR(KSC1008-Y) from noise pulse induced while the solenoid is de-energized.

### 3-5-5. PTL ACTUATION CIRCUIT

PTL actuation circuit switches its power using NPN TR.

### 3-5-6. MOTOR ACTUATION CIRCUIT

Motor actuation circuit is determined while selecting the initial driver IC (provided by the vendor). This system uses TEA3718(U9, U10), A2918(U15)'s motor driver IC. However, the sensing resistance (R56, R57, R142, R125) and reference resistance (R75, R79, R85, R86) can vary depending on the motor actuation current value.

It receives motor enable signal (2 phase) from CPU and generates bipolar pulse (constant-current) and sends its output to stepping motor input.

### 3-5-7. HIGH VOLTAGE POWER SUPPLY

#### 3-5-7-1. Summary

It is the high voltage power supply that has DC+24V/DC+5V (used for the image forming device in OA digital picture developing method) as the rated inputs. It supplies electrifying voltage (MHV), supply voltage (SUPPLY), developing voltage (DEV), blade voltage(BLADE) and transferring voltage (THV).

Each high voltage supply shows the voltage required in each digital picture process.

#### 3-5-7-2. Digital Picture Process

Digital picture developing method is widely used by copy machine, laser beam printer and fax paper.

The process is comprised of electrification, exposure, develop, transfer and fixing.

First, in the electrification process, retain constant charge at approx. -900V for the electric potential on the OPC surface by electrifying OPC drum at approx. -1.4KV through the electrification roller.

The electrified surface of OPC is exposed responding to the video data by the LSU that received print command due to rotation. The unexposed non-video section will retain the original electric potential of -900V, but the electric potential of the image area exposed by LSU will be approx. -180V that it will form the electrostatic latent image. The surface of the photo-conductive drum where the electrostatic latent image is formed reaches the developer as the drum rotates. Then the electrostatic latent image formed on the OPC drum is developed by the toner supplied to the developing roller by supplying roller and it is transformed into visible image. It is the process to change the afterimage on the OPC drum surface formed by LSU into visible image by the toner particles.

While the supply roller energized with -450V by HVPS and the developer roller energized with -300V rotate in the same

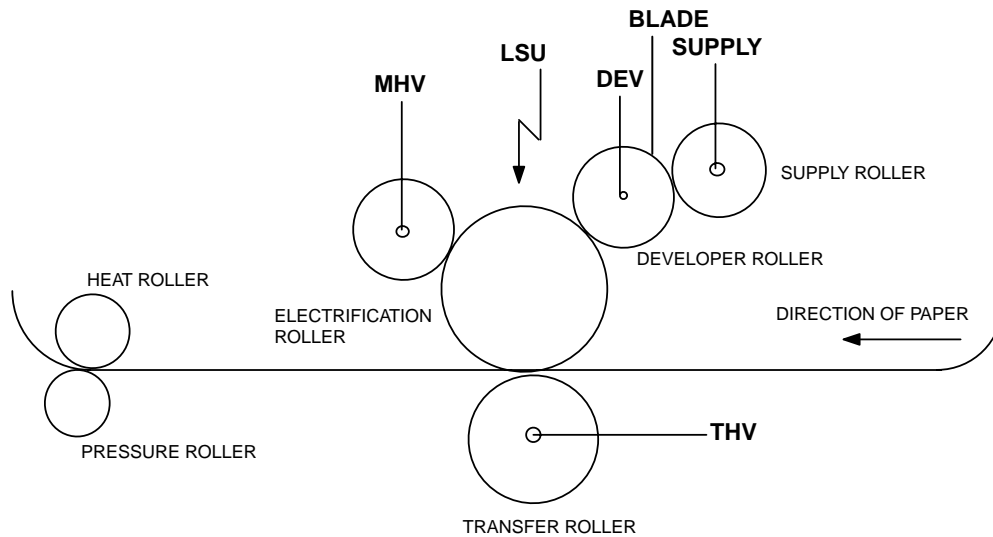

direction, it keeps the toner particles between two rollers supplied to OPC drum in negative state by the friction between two rollers.

The toner supplied to the developer roller is biased to bias electric potential by the developer roller and transferred to the developing area. After (-) toner is attached to the developer roller, it will move to the exposed high electric potential surface (-180V) rather than to the unexposed low electric potential surface (-900V) of the developer roller and OPC drum. Eventually the toner will not settle in the low electric potential surface to form the visible image.

Later, the OPC drum continues to rotate and reaches to transfer location in order to accomplish the transfer process.

This process transfers the (-)toner on the transfer roller to the printing paper by the transfer roller. The (-)toner attached to the OPC drum will be energized to hundreds to thousands of the (+)transfer voltage by HVPS. The (+)electrostatic force of the transfer roller generated has higher adhesiveness than the (-)toner OPC drum and thus it moves to the surface of the paper passing through the transfer roller. The toner transferred to the paper with weak electrostatic force is fixed to the paper by the pressure and heat of the fixer composed of pressure roller and heat roller. The toner attached to the paper is melted by applying the heat (approx. 180°C) from the heat roller and the pressure (approx. 4kg) from the pressure roller. After the fixing process, the paper is sent out of the set to finish the printing process.

### 3-5-7-3. Organization of the Device

HVPS is comprised of electrification output unit, bias output unit and transfer output unit.

- 1) Input Unit
- 2) Electrification Output (Enable) Unit: MHV (Main High Voltage)
- 3) Bias Output (Enable) Unit: DEV (Development Voltage)/Supply(Supply Voltage)/BLADE(Blade Voltage)
- 4) Transfer '+' Output (Enable) Unit: THV(+)(Transfer High Voltage(+))
- 5) Transfer '-' Output (Enable) Unit: THV(-)(Transfer High Voltage(-))
- 6) Switching Unit
- 7) Feedback Unit
- 8) Regulation Unit
- 9) Output Unit

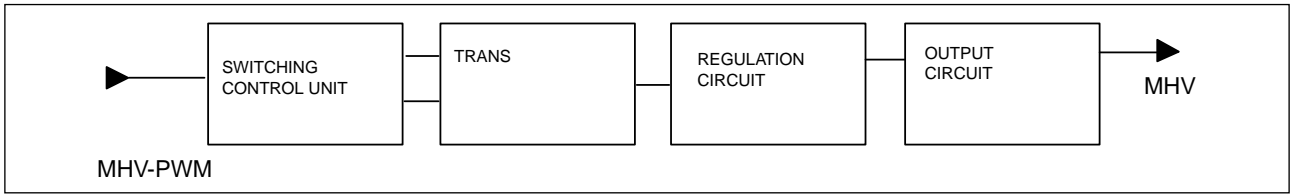

<Electrification Unit Block-Diagram>

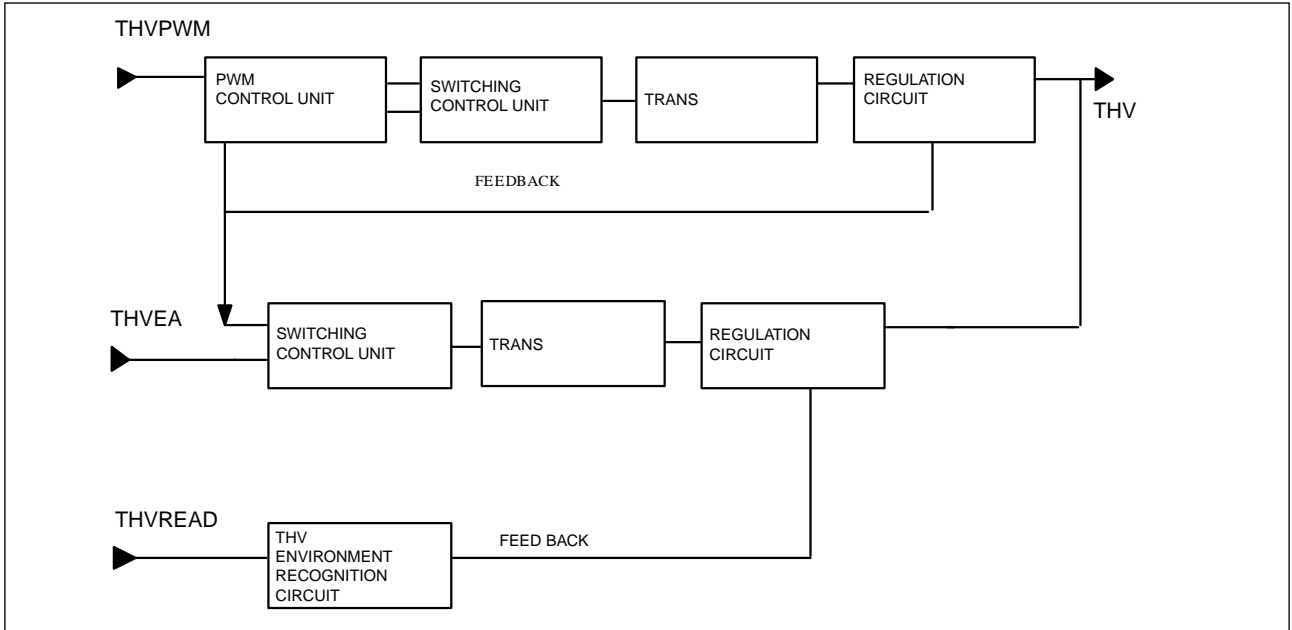

<Transfer Output Unit Block Diagram>

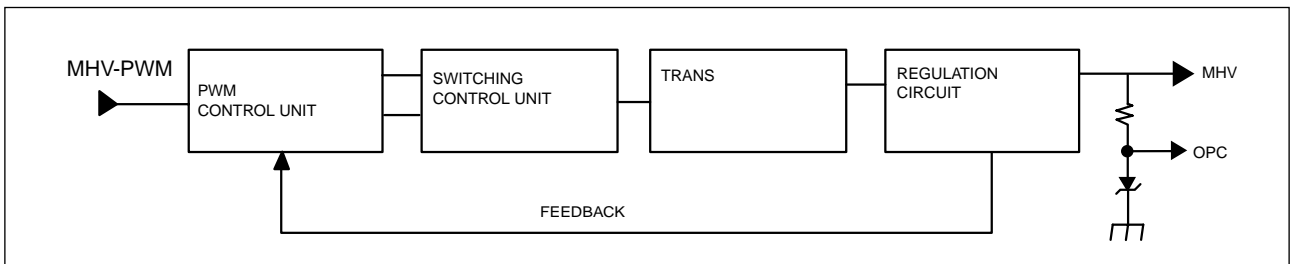

<MHV Output unit Block Diagram>

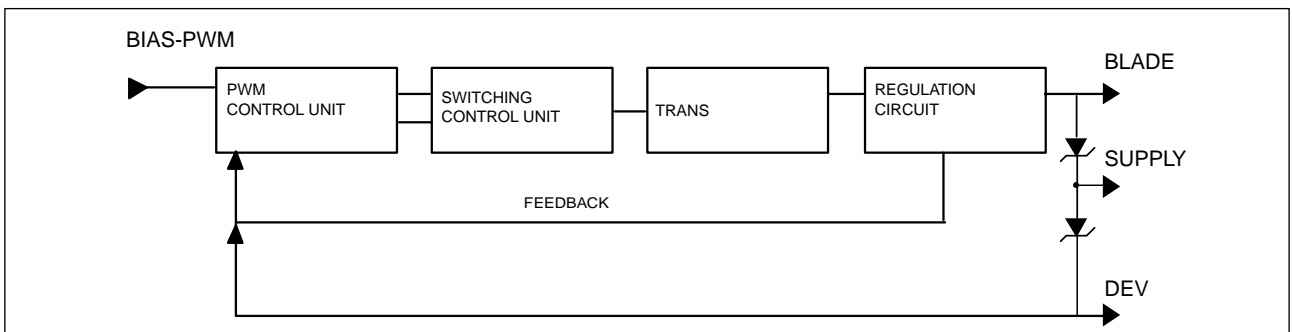

<BIAS Output Unit Block Diagram>

### 3-5-7-4 MHV (Electrification Output Enable)

Electrification Output Enable is the electrification output control signal 'PWM-LOW ACTIVE'.

When MHV-PWM LOW signal is received, Q401 turns on and the steady voltage will be accepted to the non-inverting terminal of OP-AMP 324. As the voltage higher than the inverting reference voltage of OP-AMP, which is set to R405 and R406, OP-AMP output turns high. This output sends IB to the TRANS auxiliary wire through current-restricting resistance Q402 via R408 and C403 and Q402 turns on. When the current is accepted to Q402, Ic increases to the current proportional to time through the T401 primary coil, and when it reaches the Hfe limit of Q402, it will not retain the "on" state, but will turn to "off". As Q402 turns 'off', TRANS N1 will have counter-electromotive force, discharge energy to the secondary unit, sends current to the load and outputs MHV voltage through the high voltage output enable, which is comprised of Regulation-circuit.

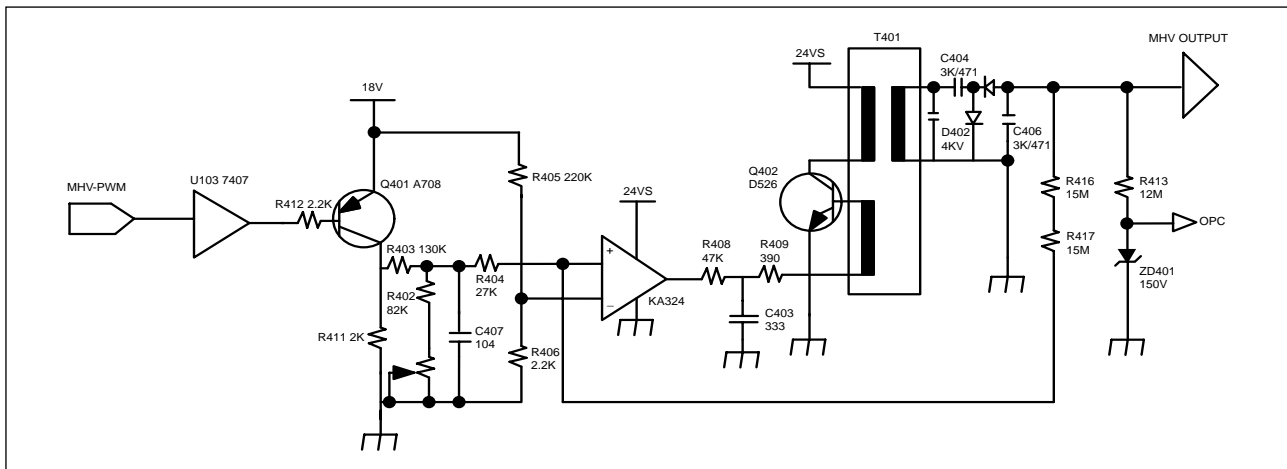

### 3-5-7-5 BIAS (supply/dev/blade output unit)

BIAS (Electrification Output Enable) Electrification Output Enable is the electrification output control signal 'PWM-LOW ACTIVE'. When BIAS-PWM LOW signal is received, Q501 turns on and the steady voltage will be accepted to the non-inverting terminal of OP-AMP 324. As the voltage higher than the inverting reference voltage of OP-AMP, which is set to R506 and R507, OP-AMP output turns high. This output sends IB to the TRANS auxiliary wire through current-restricting resistance Q502 via R509 and C504 and Q502 turns on. When the current is accepted to Q502, Ic increases to the current proportional to time through the T201 primary coil, and when it reaches the Hfe limit of Q502, it will not retain the "on" state, but will turn to "off". As Q502 turns 'off', TRANS N1 will have counter-electromotive force, discharge energy to the secondary unit, sends current to the load and outputs DEV voltage through the high voltage output enable, which is comprised of Regulation-circuit.

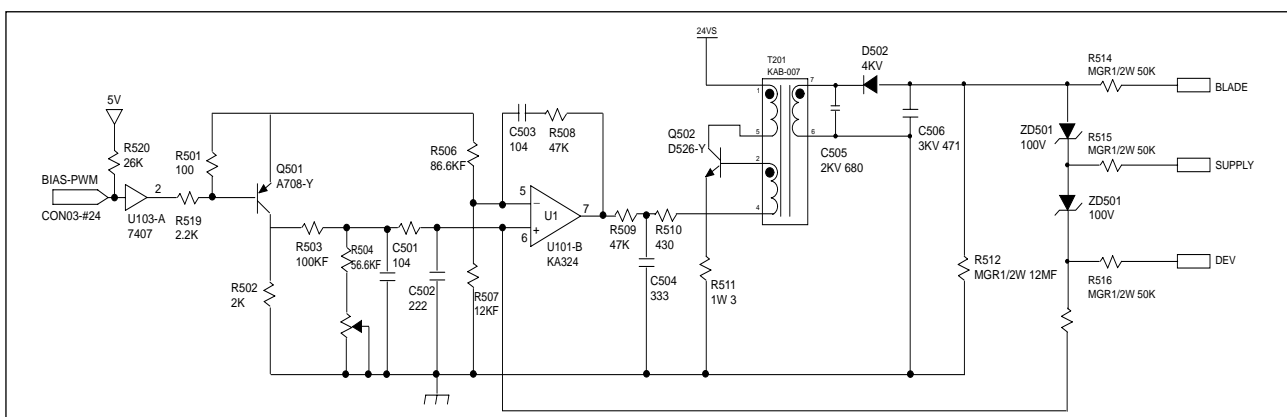

### 3-5-7-6. THV(THV(+)/THV(-) Output Unit)

Transfer(+) output unit is the transfer output control signal 'PWM-LOW ACTIVE'.

When THV-PWM LOW signal is received, Q203 turns on and the steady voltage will be accepted to the non-inverting terminal of OP-AMP 324. As the voltage is higher than the inverting reference voltage of OP-AMP, OP-AMP output turns high. The 24V power adjusts the electric potential to ZD201 and ZD202, sends IB to TRANS auxiliary wire through current-restricting resistance R215 via R212 and C204, and eventually Q204 will turn on. When the current is accepted to Q402, Ic increases to the current proportional to time through the T201 primary coil, and when it reaches the Hfe limit of Q204, it will not retain the "on" state, but will turn to "off". As Q402 turns 'off', TRANS N1 will have counter-electromotive force, discharge energy to the secondary coil, sends current to the load and outputs THV voltage through the high voltage output enable, which is comprised of Regulation- circuit. The output voltage is determined by the DUTY width. Q203 switches with PWM DUTY cycle to fluctuate the output by fluctuating the OP-AMP non-inverting end VREF electric potential, and the

maximum is output at 0% and the minimum, at 100%. Transfer(-) output unit is THV-EA 'L' enable.

When THV-EA is 'L', Q302 turns on and the VCE electric potential of Q302 will be formed and sends IB to TRANS auxiliary wire through R311, C305 and VR302 via current-restricting resistance R314, and eventually Q303 will turn on. When the current is accepted to Q303, Q303's Ic increases to the current proportional to time through the T301 primary coil, and when it reaches the Hfe limit of Q303, it will not retain the "on" state, but will turn to "off". As Q303 turns 'off', TRANS N1 will have counter-electromotive force, discharge energy to the secondary coil, send current to load and output THV(-) voltage through the high voltage output enable, which is comprised of Regulation- circuit.

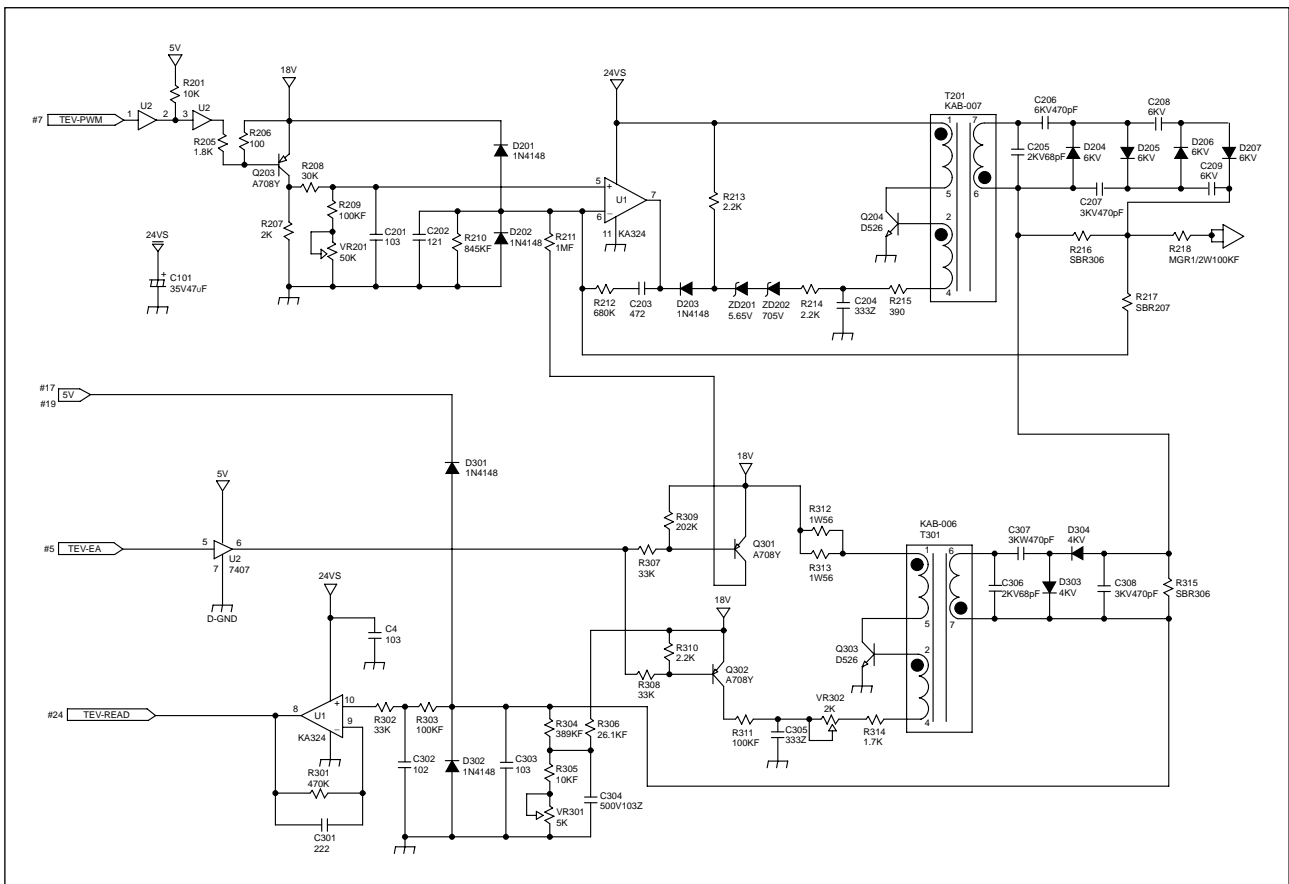

### 3-5-7-7. Environment Recognition

THV voltage recognizes changes in transfer roller environment and allows the voltage suitable for the environment in order to realize optimum image output. The analog input is converted to digital output by the comparator that recognizes the environmental changes of the transfer roller. It is to allow the right transfer voltage to perform appropriate environmental response considering the environment and the type of paper depending on this digital output by the programs that can be input to the engine controller ROM.

This environment recognition setting is organized as follows: First, set the THV(+) standard voltage.

Allow 200M $\Omega$  load to transfer output, enable output and set the standard voltage 800V using VR201.

Then set 56 (CPU's recognition index value) as the standard using VR302.

This standard value with CPU makes sure that the current feedback is 4 $\mu$ A when output voltage is 800V and load is 200M $\Omega$ . If the load shows different resistance value when 800V is output, the current feedback will also be different and thus the index value will also be different. according to the index value read by CPU, the transfer voltage output will differ according to the preset transfer table.

The changes in transfer output required by each load is controlled by PWM-DUTY.

## 3-6 OPE PBA

### 3-6-1 SUMMARY

OPE Board is separated functionally from the main board and operated by the micom(Z8601) in the board. OPE and the main use UART (universal asynchronous receiver/transmitter) channel to exchange information. OPE reset can be controlled by the main. OPE micom controls key-scanning and LCD and LED display. If there occurs an event in OPE (such as key touch), it sends specific codes to the main to respond to the situation and the main analyzes these codes and operates the system. For example, if the main is to display messages in OPE, the main transmits data through UART line to OPE according to the designated format and OPE displays this on LCD, LED. OPE's sensing is also transmitted to the main through UART line and then the main drives necessary operation.

OPE PBA consists of U1(MICOM, Z8601),LCD, key matrix, LED indicators. Refer to OPE Schematic Diagram and Wiring Diagram sections of this manual.

- Signals from the key matrix are delivered to U1 input pin group (D1~D6)
- U1 pin 48 (TX DATA) is the UART code sent to MAIN PBA.
- Display from the controller is received at U1 pin 5(RX DATA).
- LCD drive signals are sent from U1 P2-x pin group, P3-4~P3-6 pins.
- Machine status LED drive signals are sent from U1 LED 1~ LED 8.

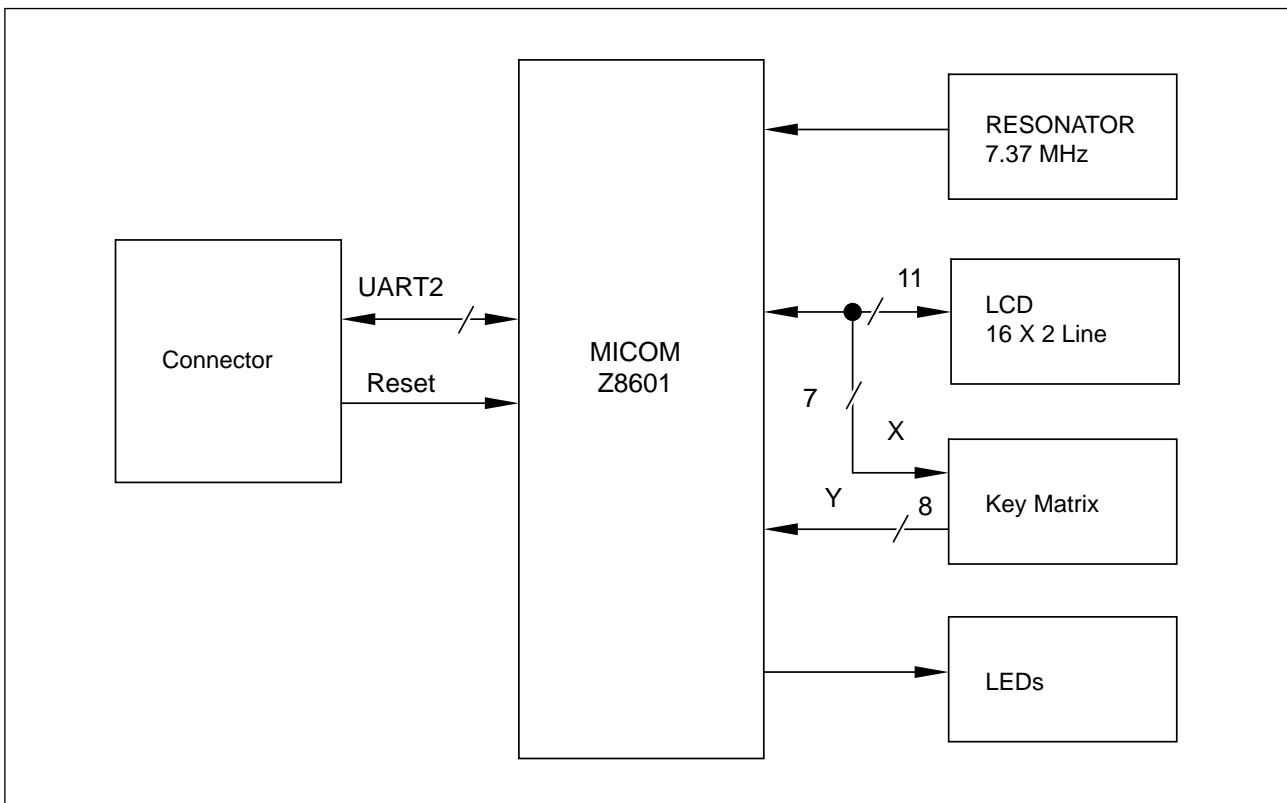

<OPE BLOCK DIAGRAM>

## 3-7 LIU PBA

### 3-7-1. SUMMARY

LIU WIRE CONNECTS Main B'D's MODEM AND LINE PARTS, AND IMPEDANCE MATCHING (AC, DC), RING DETECTION PART and LINE SEIZURE (DIALER).

### 3-7-2. DC MATCHING PART

Normal movement range of LIU is 12mA ~ 9mA.

Adapting CTR21 standard, the regulation limits to 60mA CURRENT flow through the terminal.

Therefore, select (\*:for EU PIT) Option to connect necessary items then the current through LIU will not exceed 60mA.

- CTR21 Standard(Europe) : 12mA~60mA
- OTHER Standard (U.S.) : 12mA~90mA

DC has a character to pass through the LINE. And with Q1 (VN2410) GATE section's LINE INPUT current and Q1 Source connection to R20, can be decided as follows :

- $-VDCR = VL1 + ILINE \times R20$   
(VDCR : Tip-Ring CD Voltage, ILINE : Current flow)VL1:Line Input Voltage, VL1=VBD1+VCE(Q2)+VDS(Q1)

### 3-7-3. AC MATCHING PART

Basic LIU's AC IMPEDANCE is 600 and uses R47. 48. C36 to possibly control combined IMPEDANCE.

- U.S. Usage : A terminal IMPEDANCE  $\approx 600W(\pm 30\%)$
- CTR21 : A Terminal IMPEDANCE  $\approx 270+750W//150nF$

### 3-7-4. DIALER PART

#### \*MF DIAL

DTMF Dialing is controlled by MODEM and should be selected by appropriate LEVEL and On-off Time output based on each countries' own National specification.

- Tolerance :  $\pm 1.5\%$   
High Group : 1209, 1336, 1477, 1633Hz  
Low Group : 697, 770, 852, 941 Hz

	U.S. Usage	CTR21
High Freq Level	-9.0+2.0/-2.5	-7.0 +1.0/-2.0
Low Freq Level	-9.0+1.0/-2.0	-11.0+2.5/-2.0

#### \*DP DIAL

Controls from MAIN through / DP-Terminal.

for U.S.Usage, set time to DF signal of 40:60 M/B. DP signal is made of U6 (pcb817). The DC current which flows thru Q2 Base is regulated by On/Off switch and turns to DP dial signal with a COUPLER.

- CTR 21 does not have telephone capability but has the number 3 and 4 Line Connection. No DP condition but possibility to get approval only on DTMF Dial based terminal.

### 3-7-5. RING DETECTION PART

RING SIGNALS from the LINE section (TIP, RING) are further passed through C5, R3, ZD1, and ZD2 and ends up at U9, (PC 814). U9 then detects above RING SIGNAL and passes the output to MAIN B'D. The wire diagram's C5 is RINGER CAPACITOR and it normally uses 1UF/250V.

A R3 limits AC current and controls upper and lower REN meter.

## 3-8 SMPS (Switching Mode Power Supply) Unit.

### 3-8-1 SMPS SPECIFICATIONS

The SMPS (Switching Mode Power Supply) Unit used here is a PWM (Pulse Width Modulation) type power supply unit that supplies DC+5V to controller and control panel, and DC+5V, DC+24V and DC+12V to the engine. It also supplies AC power to fixer heat lamp.

No.	Output Channel	Ch.1	Ch.2	Ch.3
1	Channel Name	+5.1V	+24.0V	+12.0V
2	Rated Output Voltage	+5.1V	+24.0V	+12.0V
3	Rate Output Current	2A	2.5A	1.0A
4	Maximum Load Current and Load Pattern	3A Continued	3.5A Continued	1.0A Continued
5	Load Change Range	0.5~2.0A	0.3~2.5A	0.2~1.0A
6	Rate output voltage (For rated I/O)	+5.1V±5% (+4.84~+5.35V)	+24.0V±10% (+21.60~+26.40V)	+12V±5% (+11.40~+12.60V)
7	1) Total Output Voltage Deviation (Input, Load, Temp., Aging)	Including All +5.1V±5% (+4.84~+5.35V)	Including All +24.0V±10% (+21.60~+26.40V)	Including All +12V±5% (+11.40~+12.60V)
	2) Dynamic Input Change	Including Set Error	Including Set Error	Including Set Error
	3) Dynamic Load Change			
8	Refer to ripple & noise 27)	150mVp-p or less	500mVp-p or less	150mVp-p or less
9	Refer to load short and overload protection 23) Refer to load short and overload protection 23)	Must not ignite or generate smoke when output shorted for 5 sec.	Output voltage must shutdown withing the range of 3.5A~6.5A	Must not ignite or generate smoke when output shorted for 5 sec.

### 3-8-2 AC INPUT STAGE

AC Input power path is consist of the Fuse (F501) for AC current limit, the Varistor (TNR501) for by-passing high Voltage Surge, the discharge resistor(R508), the AC Impulse Noise Filtering Circuit (C501, LF501, C503), the Common Mode Grounding Circuit (C504, C505), the 2'nd noise filter (LF502), and the thermistor (TH501).

Wher power is turned on, TH 501 limits Inlush-Current by it's high resistanle, and When it's temperature rise, it's resistance become about Zero ohm.

### 3-8-3 SMC(SWITCHED MODE CONTROL)

The AC input voltage is rectified and filtered by BD552 and C507 to create the DC high voltage applied to the primary winding of T501. TR01 pin #1 is driven by the SMPS device U502. U502. auto-starts and chops the DC voltage. The U502 is PWM SMPS IC and has internally a SMC(switcheD mode control) IC and a MOSFET output stage. The SMC IC has a Auto-restart without a Power Supply for the IC and a Thermal Shutdown function and so on. C509, R512, C510, D505 clamp leading-edge voltage spikes caused by transformer leakage inductance.

The power secondary winding(pim #11-12)is rectified and filtered by D507, C552, L551, and C554 to create the 5V output voltage. The bias winding(pin #4-5)is rectified and filltered by D506 and C511 to create U502 bias voltage. The secondary output 5V is regulated through the path of the voltage divide by R553, R556-U503 switching PC252-the bias voltage of U502-U503 PWM duty cycle-T501 secondary voltage. C508 filters internal pin, determines the auto-restart frequency, and together with R506, compensates the control loop. U552 of the secondary stage -12V is the Low Power-loss Regulator with built-in overcurrent protection function

### 3-8-4. FIXED TEMPERATURE CONTROL

#### 3-8-4-1. Fixed Lamp Control Circui

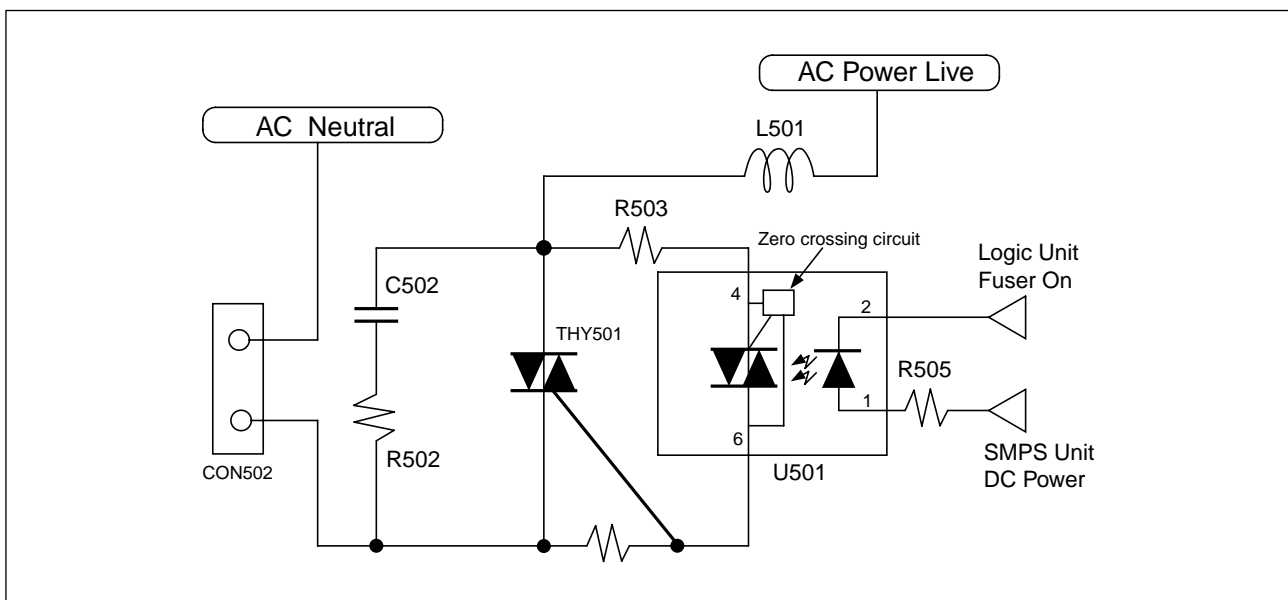

<Fixed Lamp Control Circuit>

### 3-8-4-2. The Concept of Fixed Lamp Control

For fixed lamp control, the logic unit "fuser on" control signal and SMPS unit DC power must be supplied. This circuit turns on only when "fuser on" sends the signal and the DC power is supplied.

The following explains how the fixed lamp control circuit works.

logic unit "fuser on" sends trigger current to triac driver U501 LED, then the infrared ray is detected by U501 photo detector. Next, U501 triac is conducted.

The conducted current sends trigger input to triac THY501 gate. At this point, THY501 is conducted and AC power is supplied to fixed lamp. Lamp is turned on and temperature rises.

As this fixed lamp control circuit uses the AC voltage ("+" and "-" are repeated) as the power supply, it used two-way triac (THY501), which has advantage over one-way SCR considering the price, size and reliability.

Triac's gate can be triggered by either forward or reverse signal. Once triac is turned on, it will not be controlled by gate signal, but will be continuously on until the current between major terminals decreases below the holding current. In other words, you cannot turn it off with reverse signal unlike SCR. This property is called current-voltage threshold rise rate (commutation:  $dv/dt$ ). In AC power control

application, triac has to turn off conduction in each zero crossing or switch it twice in each cycle. This switching operation is called commutation. It is possible to turn off the triac at the end of half cycle by eliminating the gate signal when the load current ( $I_L$ ) is gained at the level equal to or lower than holding current. When triac commutes off-line, the direction of the voltage of the both ends of triac will be reversed and increase up to the maximum value of line voltage ( $V_{AC}$ ). At this point, the width of rise rate will be determined by  $dv/dt$  and overshoot voltage, by the circuit. When triac commutes off-line, the voltage of both ends of triac will have the same voltage as the line voltage.

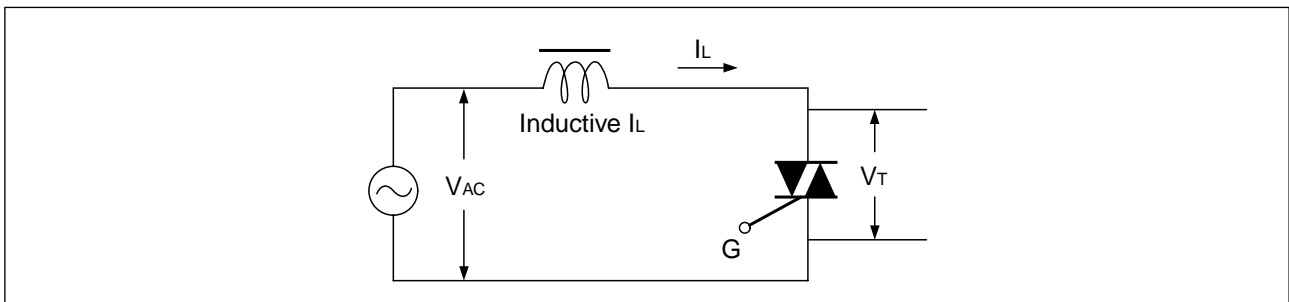

<Inductive Circuit>



Main Circuit Diagram (2/17)

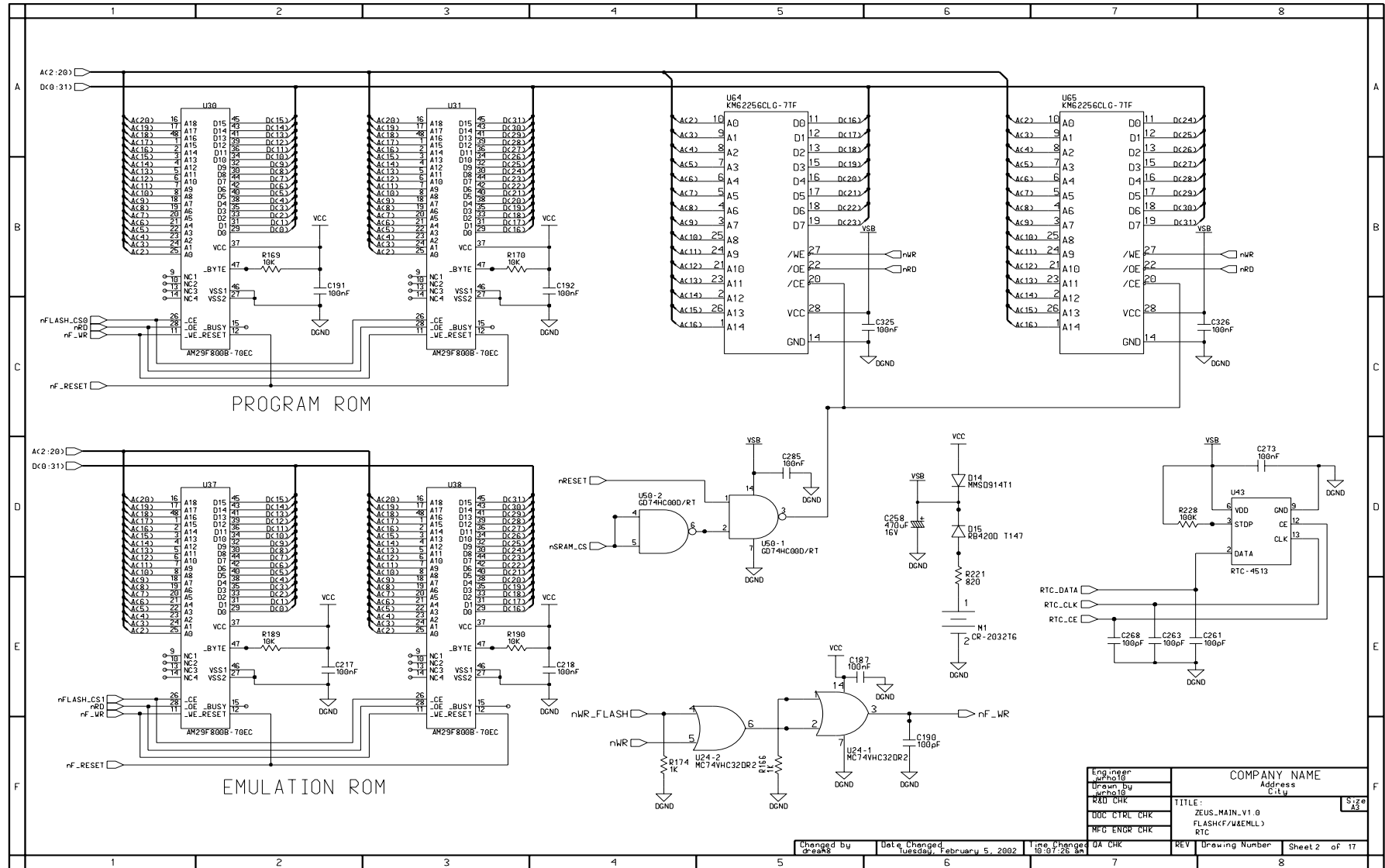

- This Document can not be used without Samsung's authorization -

Main Circuit Diagram (3/17)

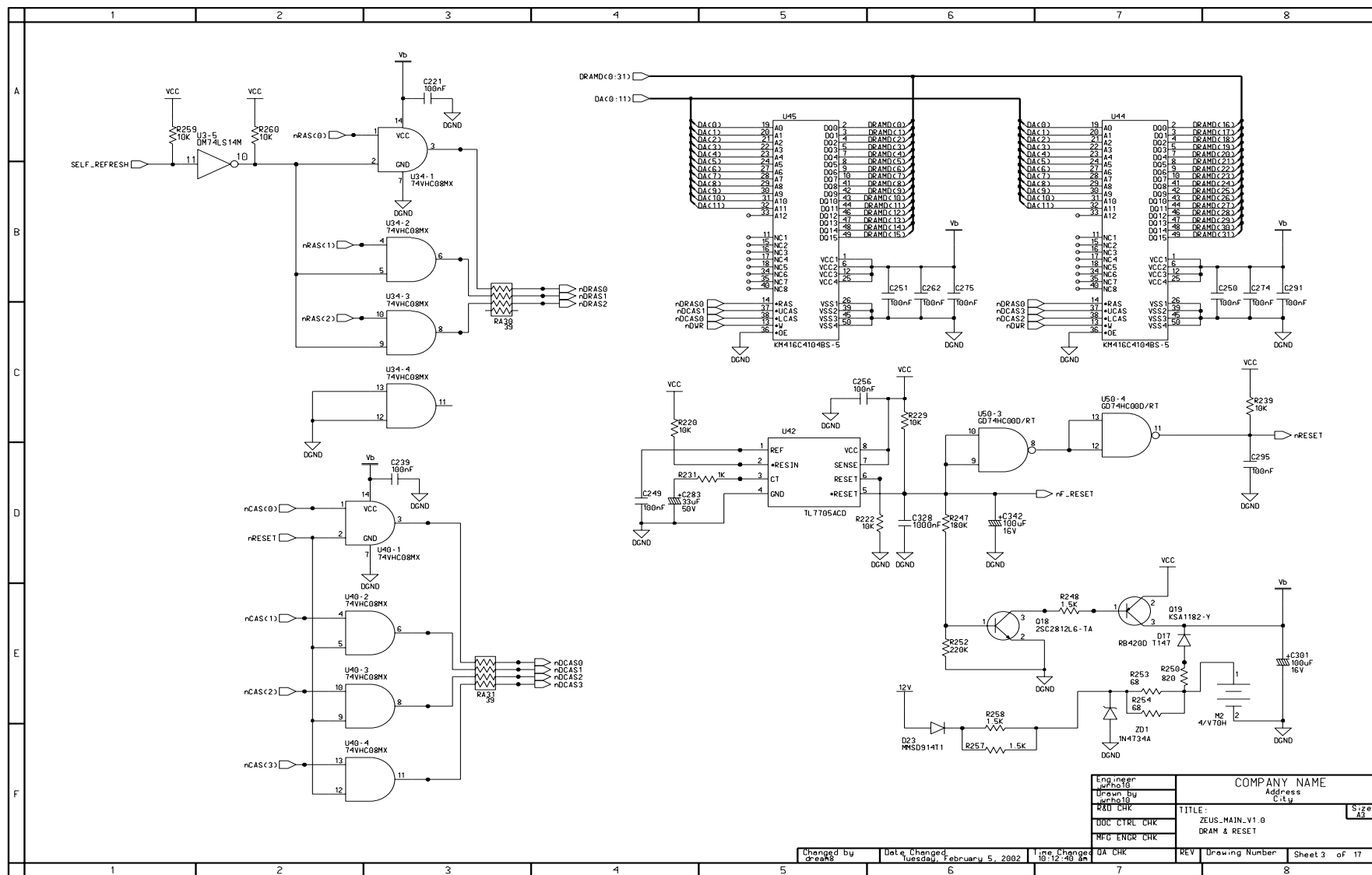

Main Circuit Diagram (4/17)

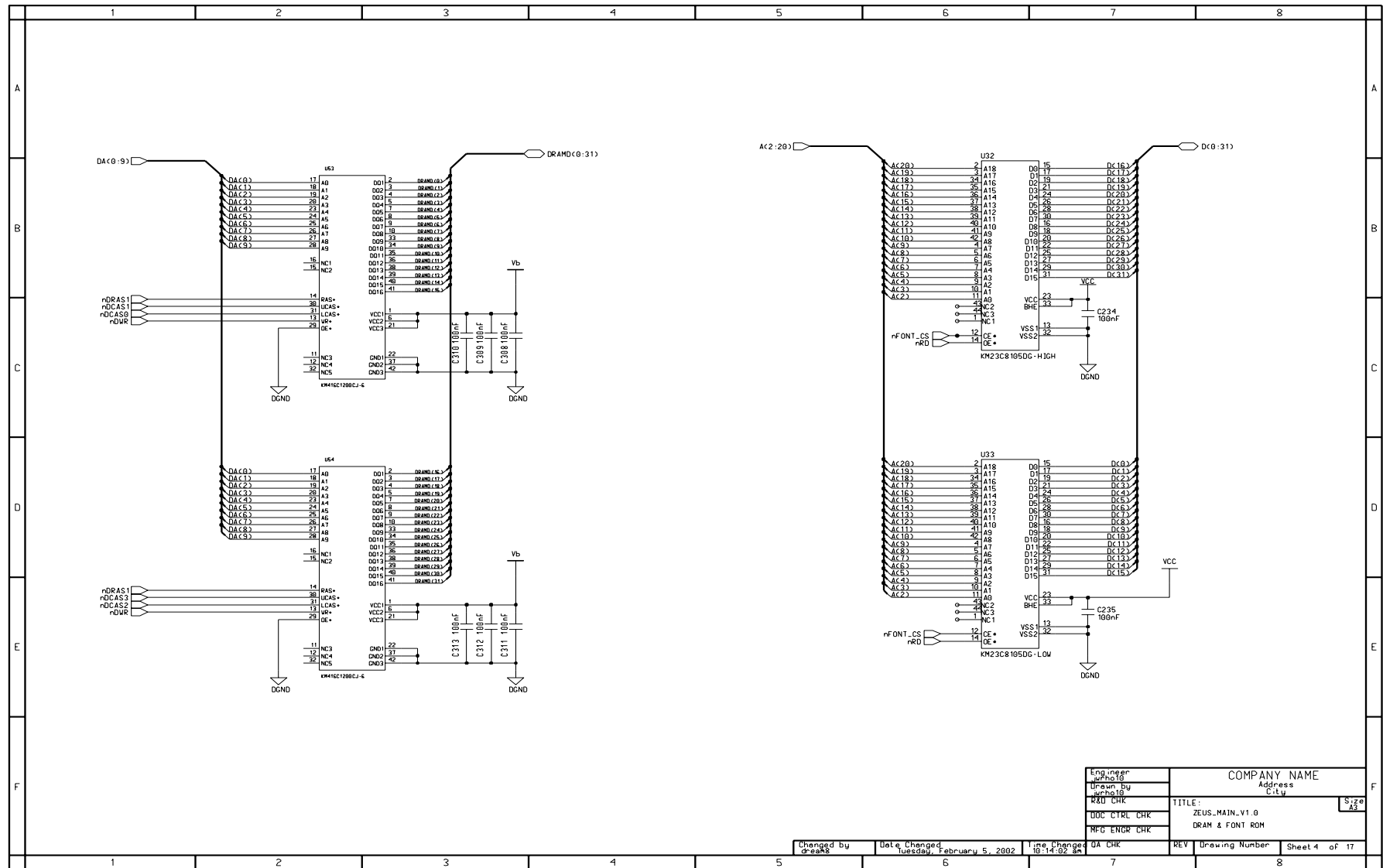

Engineer	gdn016	COMPANY NAME
Drawn By	gdn016	Address
REV CHK	gdn016	City
DOC CTRL CHK	DA CHK	TITLE
MFG ENGR CHK	DA CHK	ZEUS_MAIN_V1.0
		DRAM & FONT ROM

Changed by	Date Changed	Time Changed	REV	Drawing Number	Sheet 4 of 17
gdn016	Tuesday, February 5, 2002	10:14:02 AM	DA CHK		

Main Circuit Diagram (5/17)

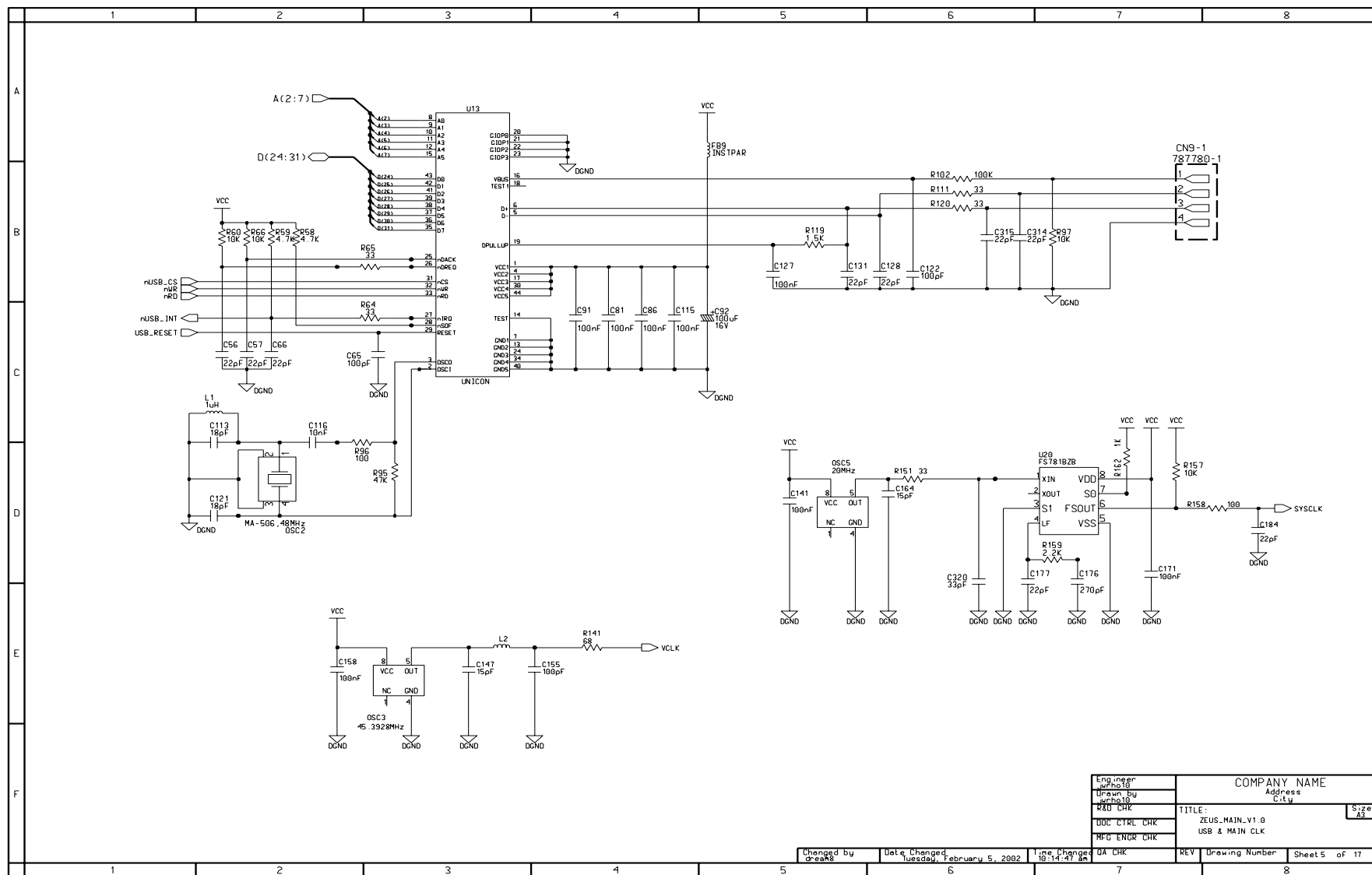

Eng. In Charge	COMPANY NAME	
Drawn By	Address	
Rev. No.	City	
REV. CHK	TITLE: ZEUS-MAIN-V1.0	Size: A3
DOC CTRL. CHK	USB & MAIN CLK	
MFG ENGR. CHK		

Changed by: DA CHK	Date Changed: Tuesday, February 5, 2002	File Changed: 10-14-07.dwg	REV	Drawing Number	Sheet 5 of 17
--------------------	---	----------------------------	-----	----------------	---------------

Main Circuit Diagram (6/17)

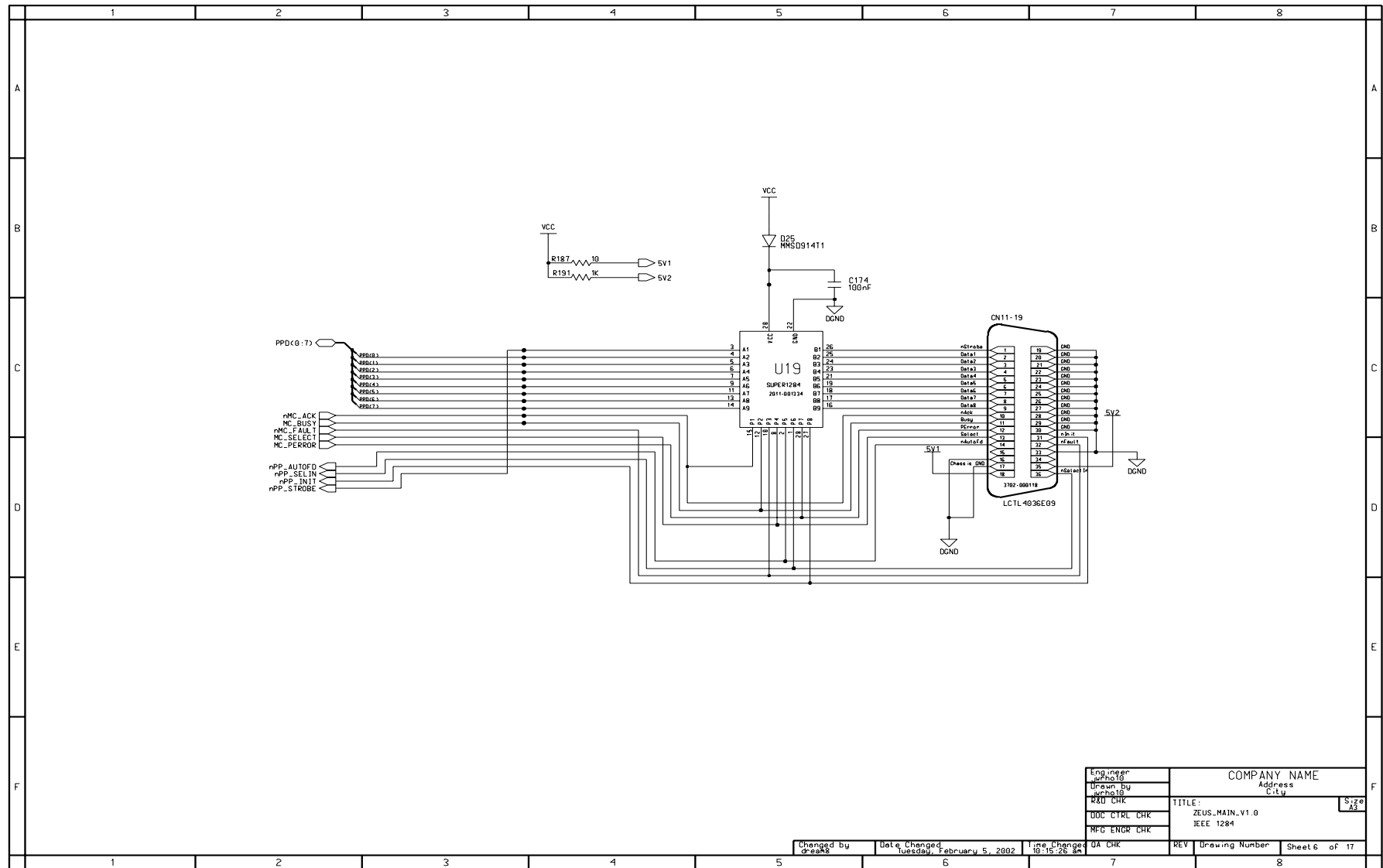

Main Circuit Diagram (7/17)

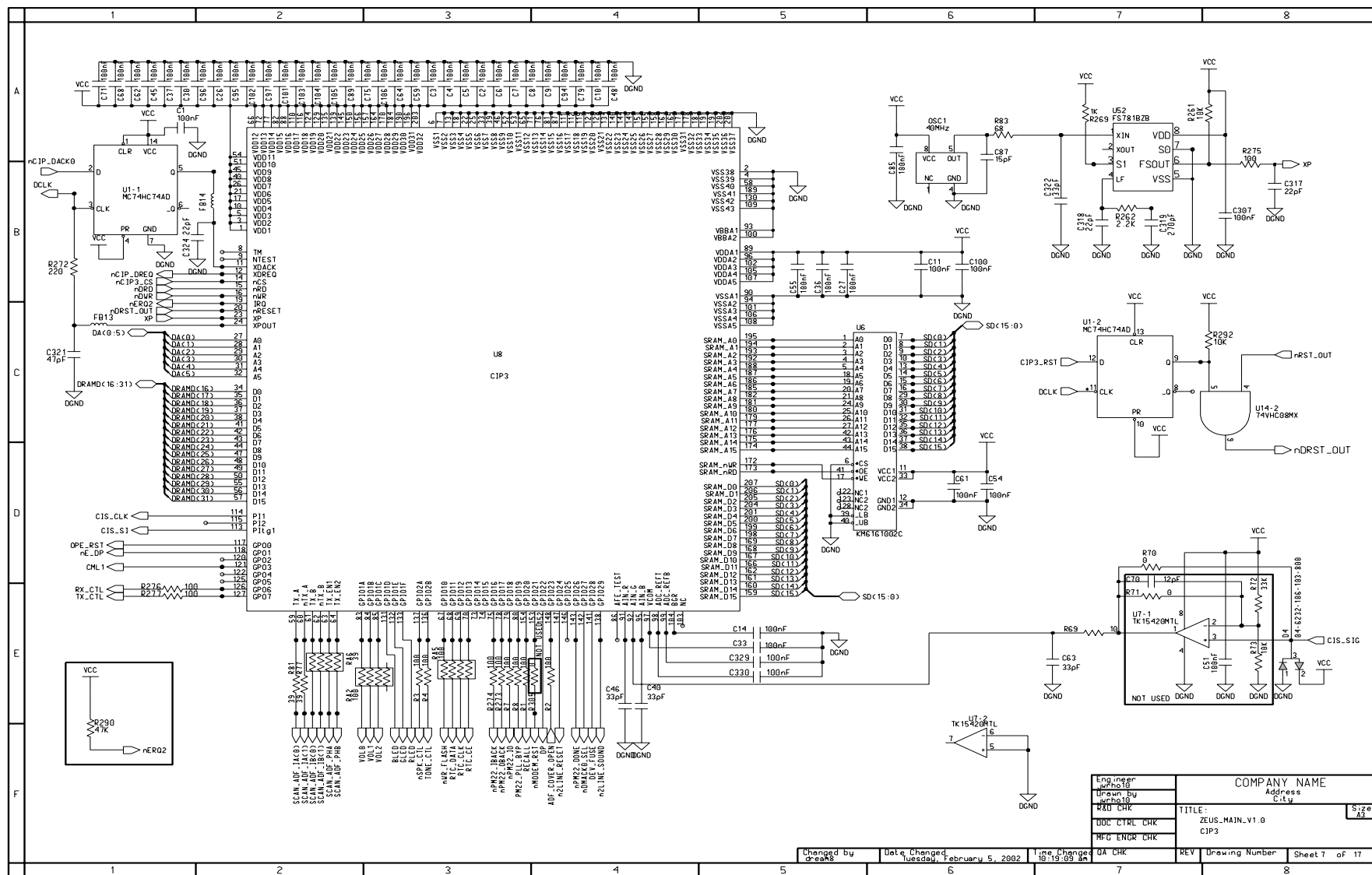

Main Circuit Diagram (8/17)

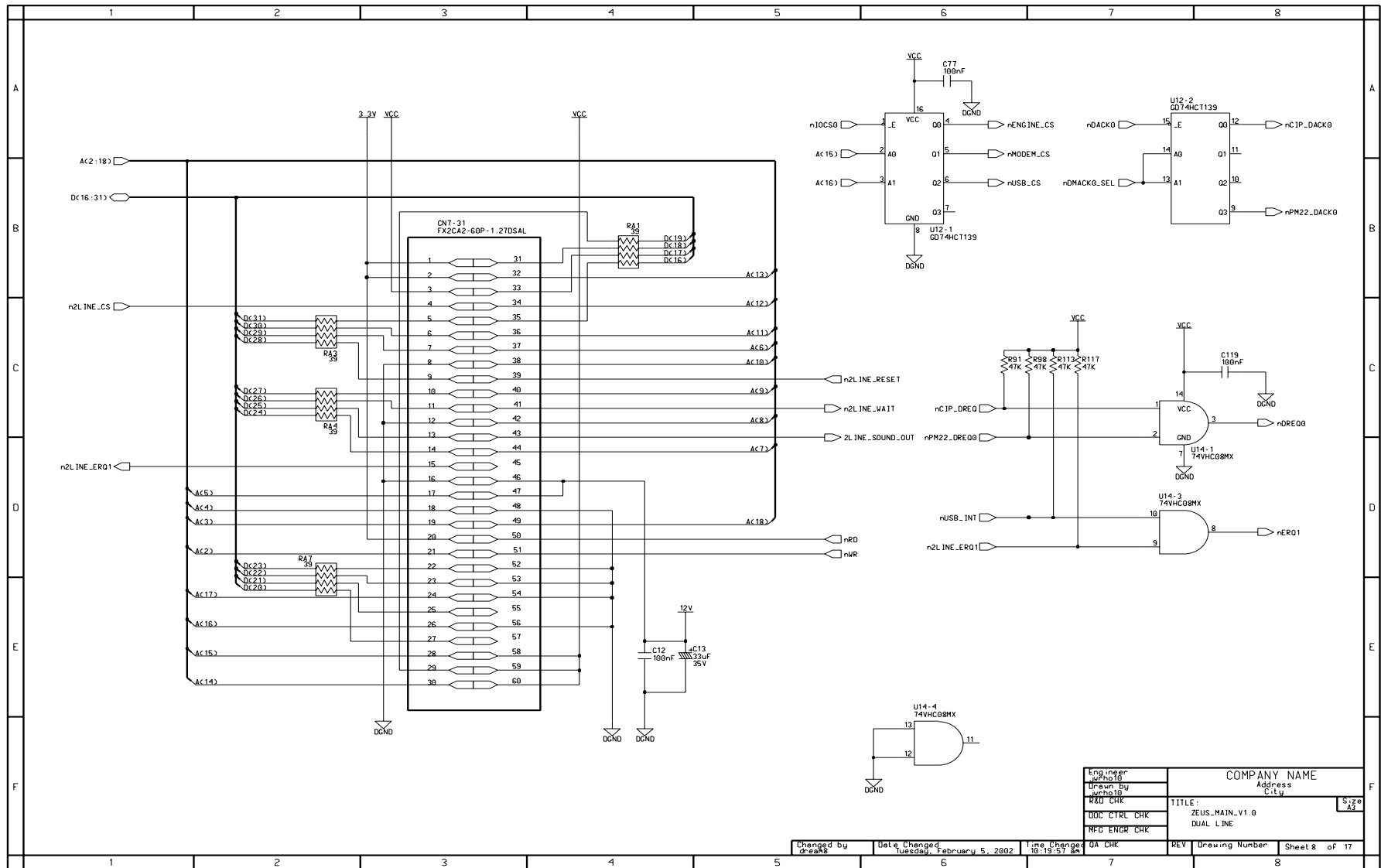

Engineer	COMPANY NAME	
Drawn By	Address	
REV	City	S:20
DOC CTRL CHR	TITLE - ZEUS_MAIN_V1.0	AS
MFG ENGR CHR	DUAL LINE	

Changed by	Date Changed	Line Changed	DA CHK	REV	Drawing Number	Sheet 8 of 17
g-rahs	Tuesday, February 5, 2002	10:10:57 AM				

Main Circuit Diagram (9/17)

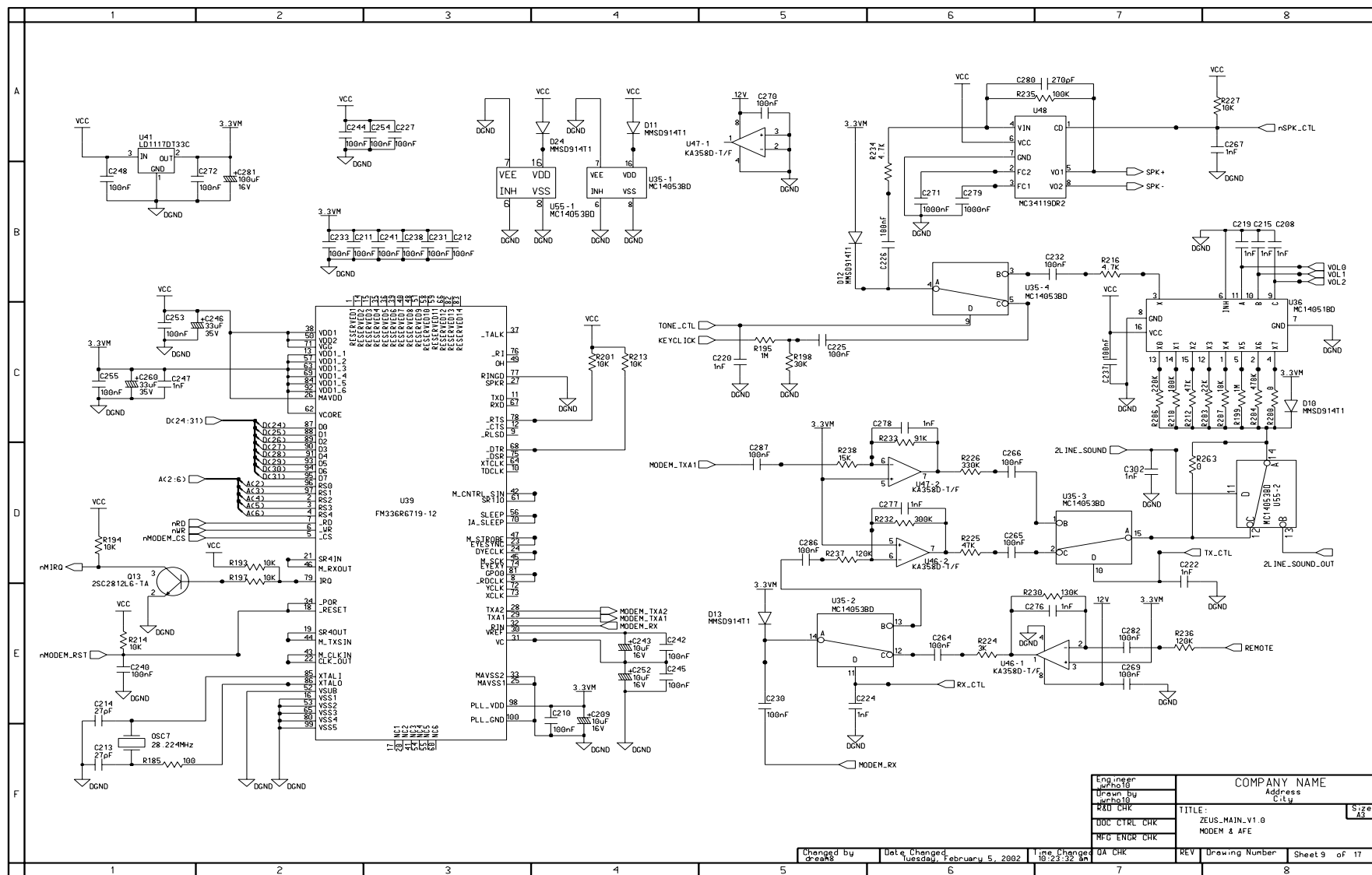

Eng. In-charge	COMPANY NAME	
Drawn By	Address	
Rev. No.	City	
RDG CHK	TITLE: ZEUS-MAIN-V1.0	Size A3
DDG CTRL CHK	MODEM & AFE	
MFG ENGR CHK		

Changed by	Date Changed	Time Changed	QA CHK	REV	Drawing Number	Sheet 9 of 17
Drains	Tuesday, February 5, 2002	10:23:32 AM				

Main Circuit Diagram (10/17)

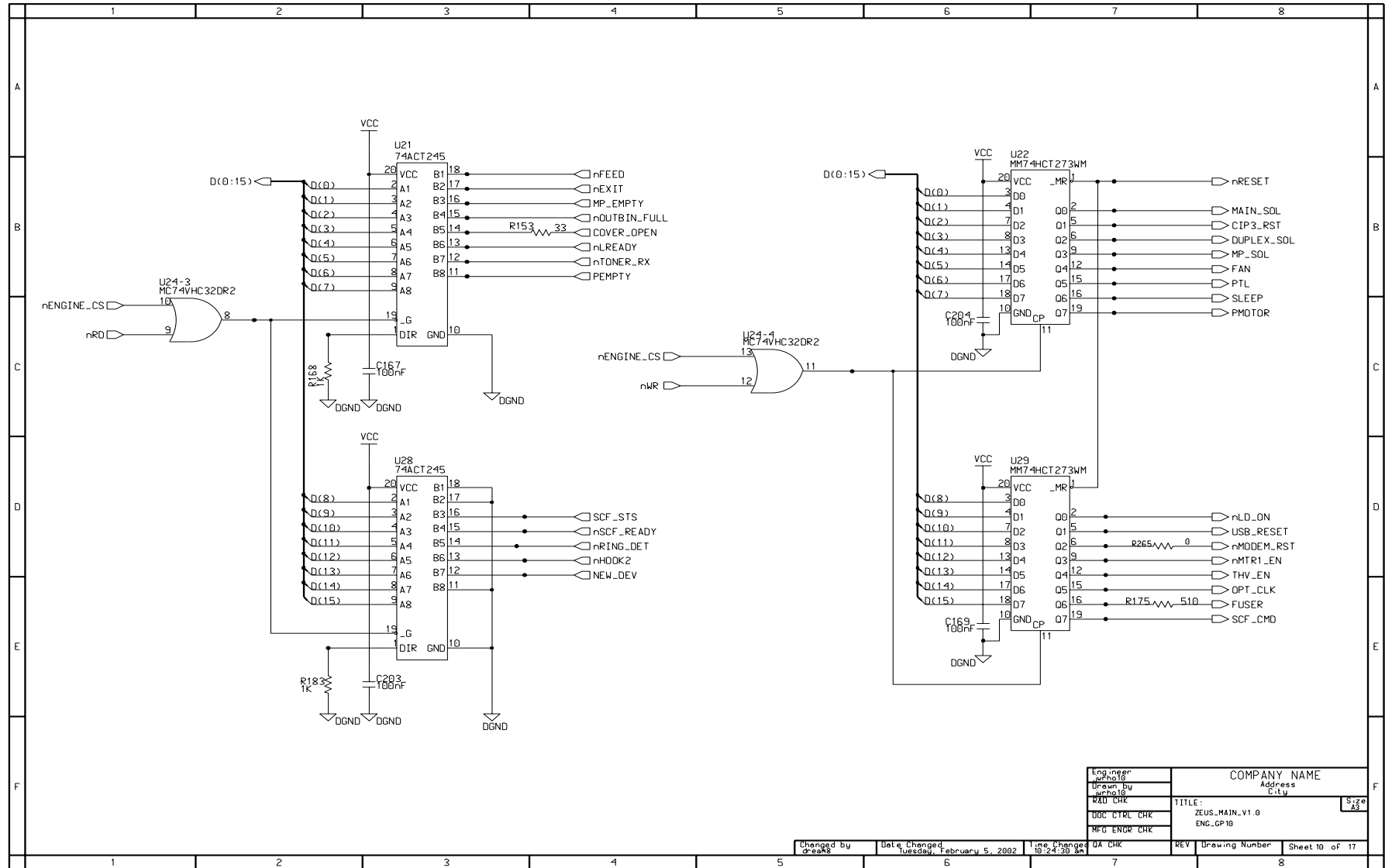

Main Circuit Diagram (11/17)

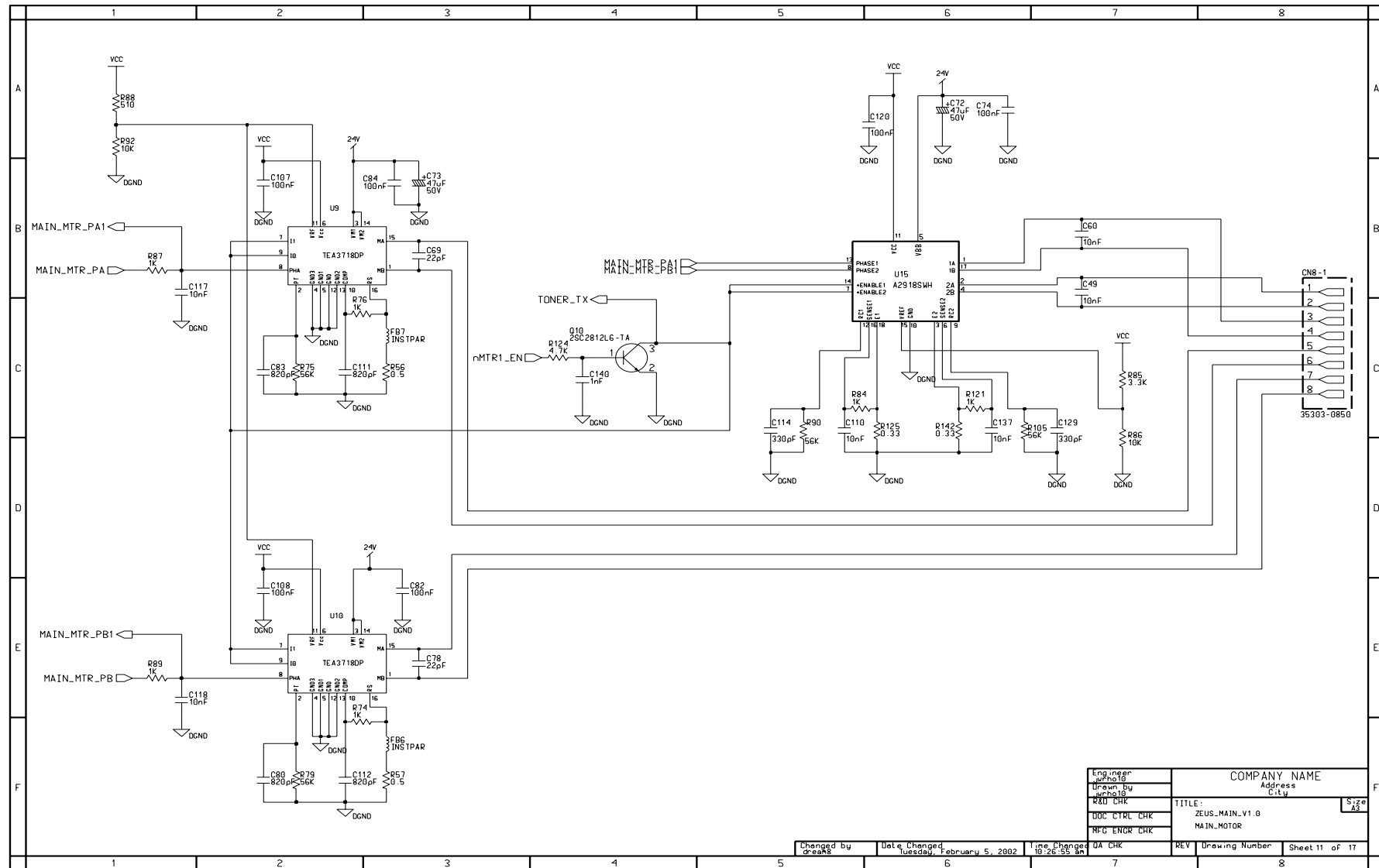

Eng. Inscr.	Company Name
Drawn By	Address
Rev. No.	City
QC CK	TITLE: ZEUS-MAIN-V1.0
QC CK	Size A3
MFG ENGR CK	MAIN_MOTOR

Changed by	Date Changed	Time Changed	QA CK	REV	Drawing Number	Sheet 11 of 17
Drawn	Tuesday, February 5, 2002	10:26:55 AM				

Main Circuit Diagram (12/17)

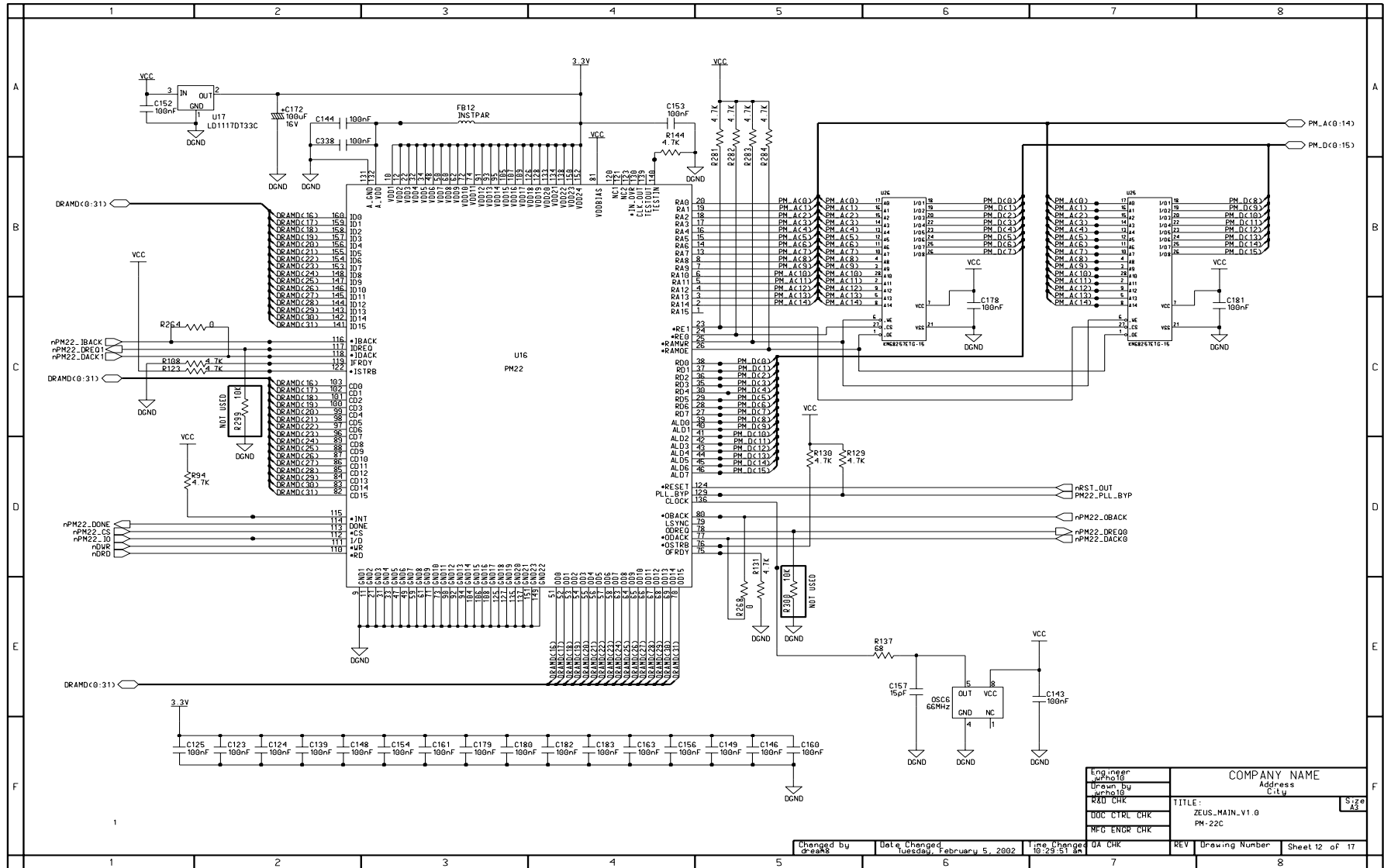

Engineer	COMPANY NAME	
Drawn By	Address	
Rev'd By	City	
DOC CTRL CHR	TITLE:	S:20
MFG ENGR CHR	ZEUS_MAIN_V1.0	As
	PM-22C	

Changed by	Date Changed	Time Changed	DA CHK	REV	Drawing Number	Sheet 12 of 17
g-wahs	February 5, 2002	10:23:51 AM				

- This Document can not be used without Samsung's authorization -

Main Circuit Diagram (13/17)

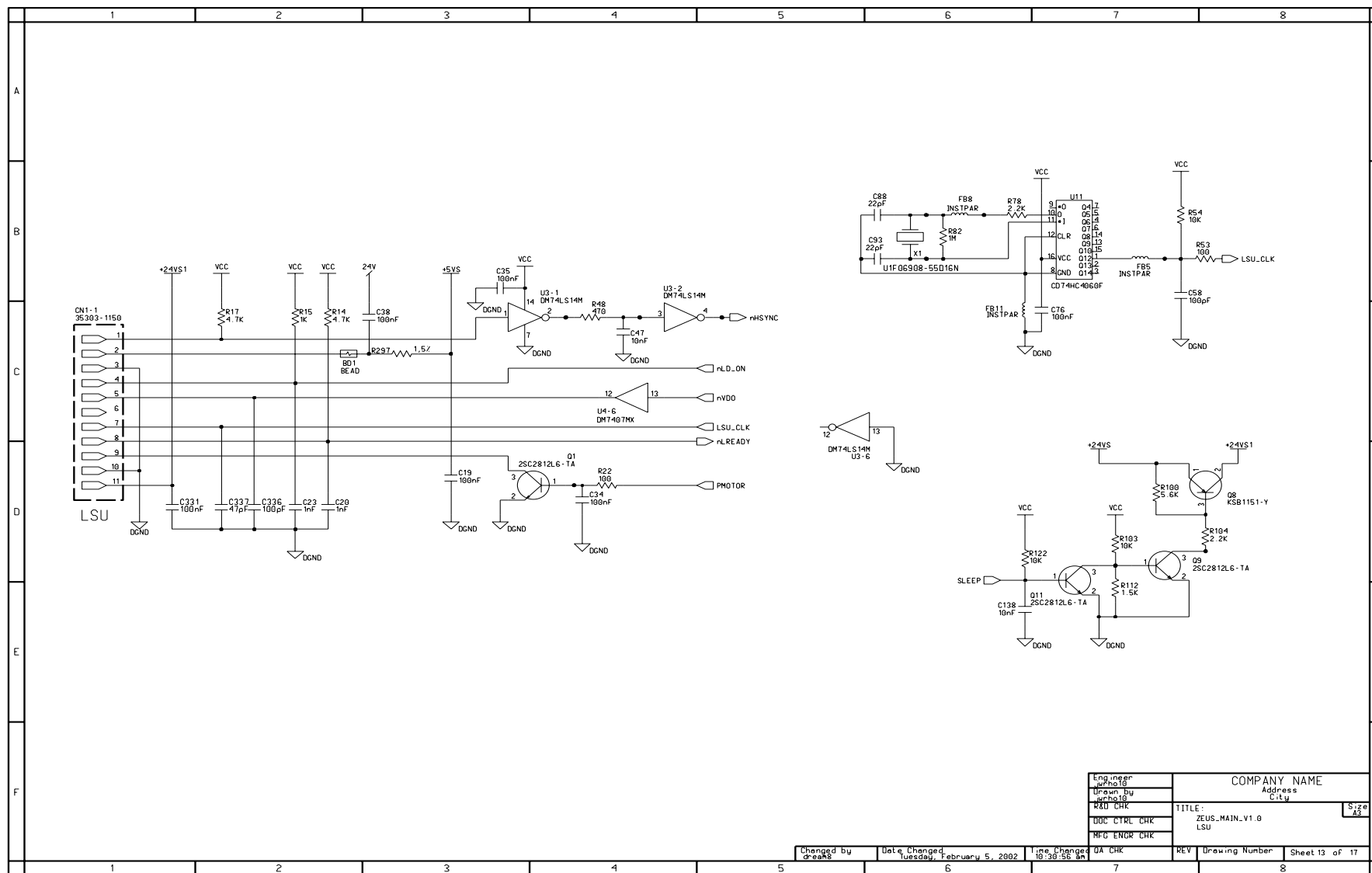

Eng. Inscr.	COMPANY NAME	
Drawn By	Address	
Rev. No.	City	
RDG. CHK.	TITLE: ZEUS-MAIN-V1.0	Size A3
DDG. CTRL. CHK.	LSU	
MFG. ENGR. CHK.		

Changed by	Date Changed	Time Changed	QA CHK	REV	Drawing Number	Sheet 13 of 17
grrans	Tuesday, February 5, 2002	10:30:55 AM				

Main Circuit Diagram (14/17)

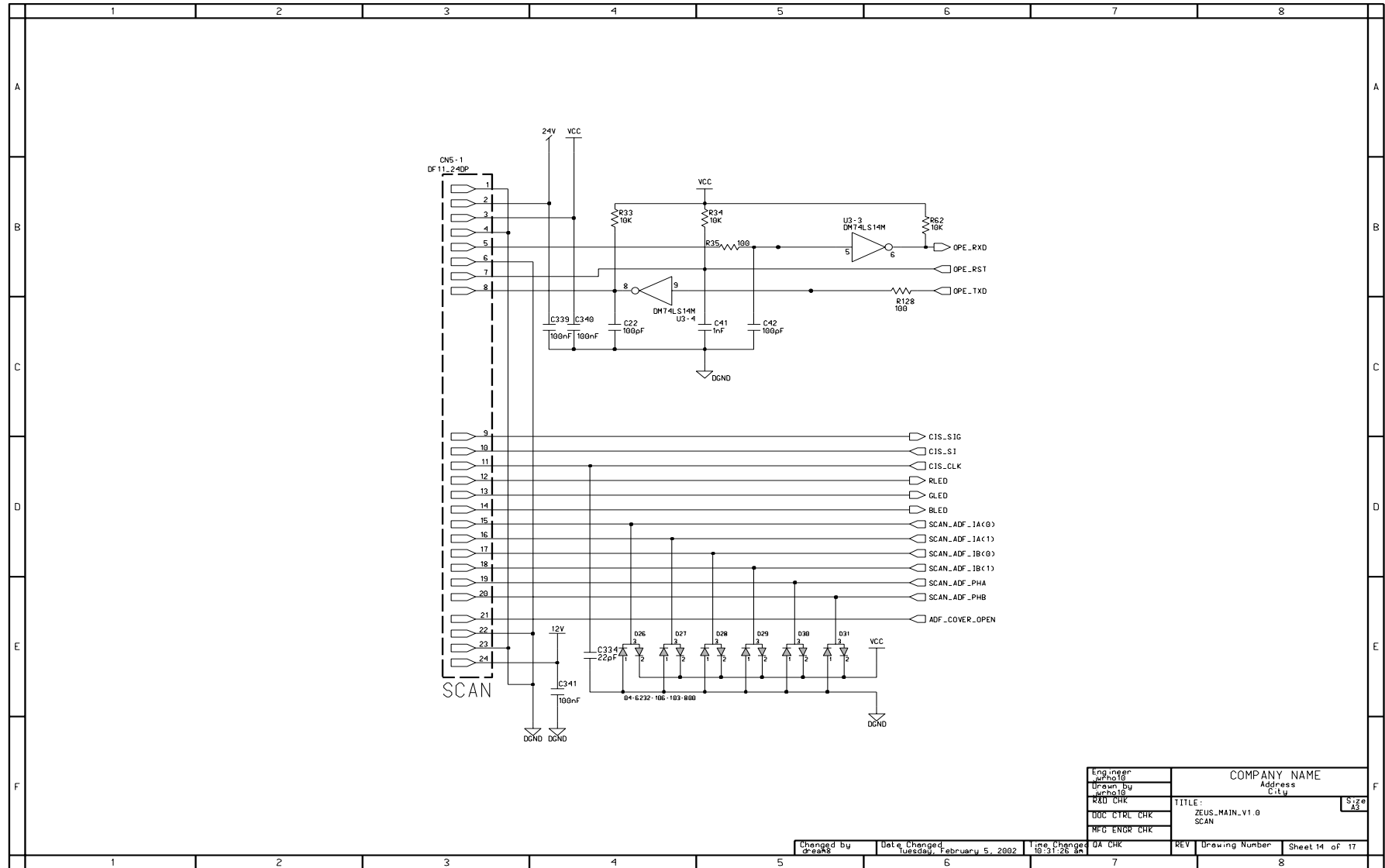

Engineer	COMPANY NAME		
Drawn By	Address		
REV	City	Size	As
DOC CTRL CHR	TITLE - ZEUS_MAIN_V1.0		
MFG ENGR CHR	SCAN		

Changed by	Date Changed	Time Changed	DA CHK	REV	Drawing Number	Sheet 14 of 17
grahns	Tuesday, February 5, 2002	10:31:26 AM				

Main Circuit Diagram (15/17)

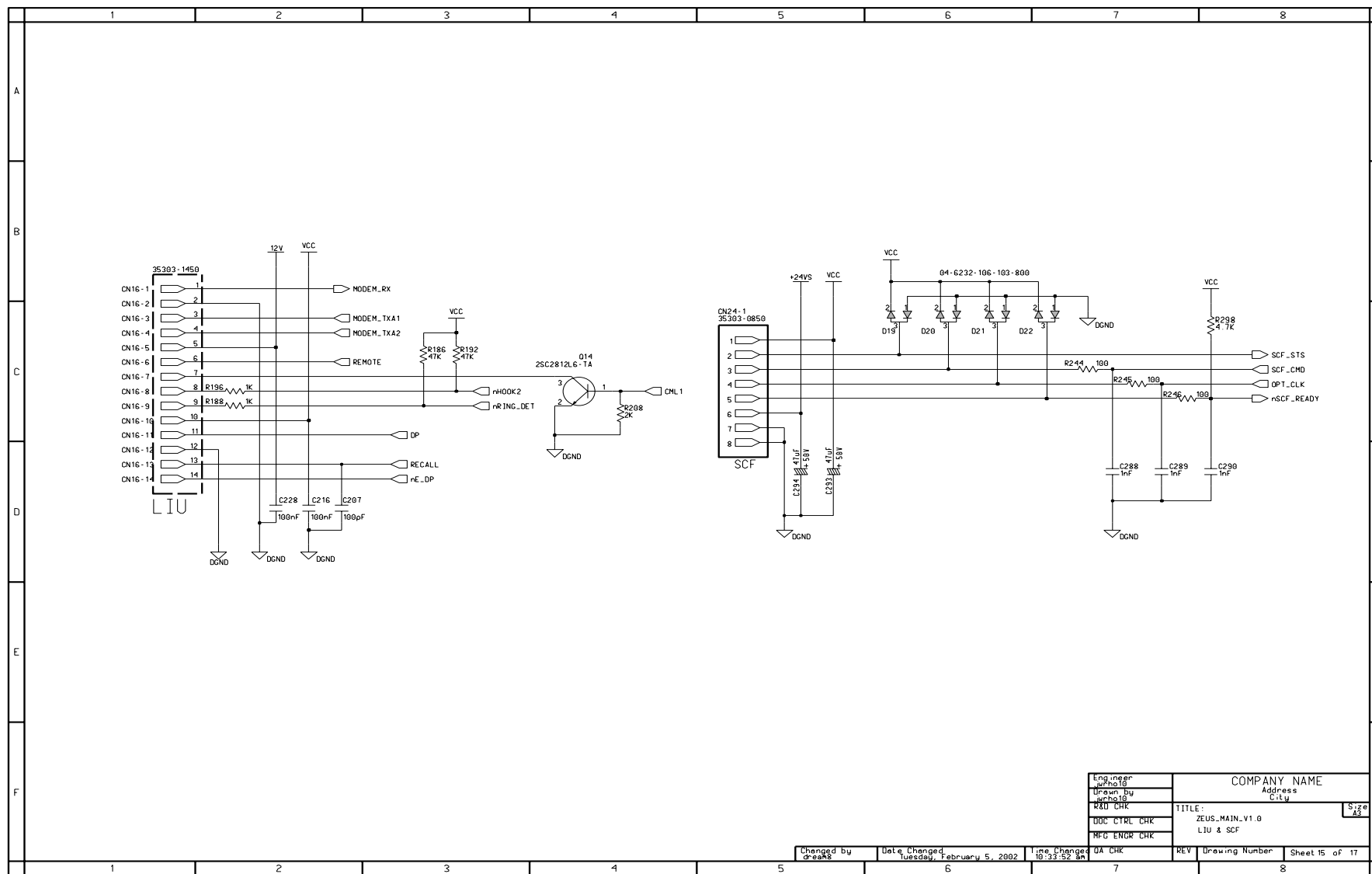

Eng. Inscr. p/n: 16	COMPANY NAME	
Drawn By p/n: 19	Address	
RDG. CHK	City	
DDG. CTRL. CHK	TITLE: ZEUS_MAIN_V1.0	Size A3
MFG. ENGR. CHK	LIU & SCF	

Changed by Draughts	Date Changed Tuesday, February 5, 2002	Time Changed 10:23:52 AM	DA CHK	REV	Drawing Number	Sheet 15 of 17
------------------------	---	-----------------------------	--------	-----	----------------	----------------

Main Circuit Diagram (16/17)

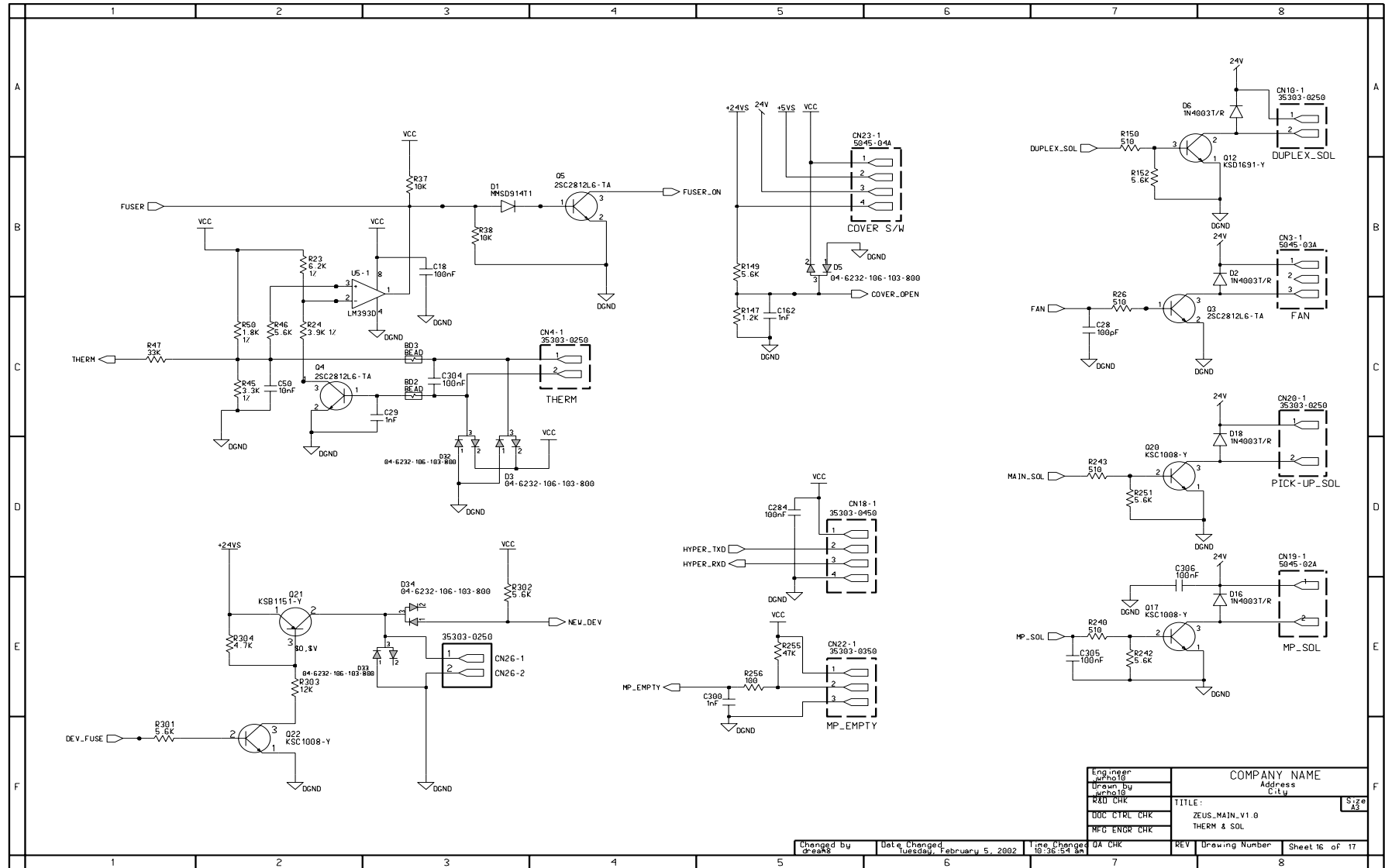

Main Circuit Diagram (17/17)

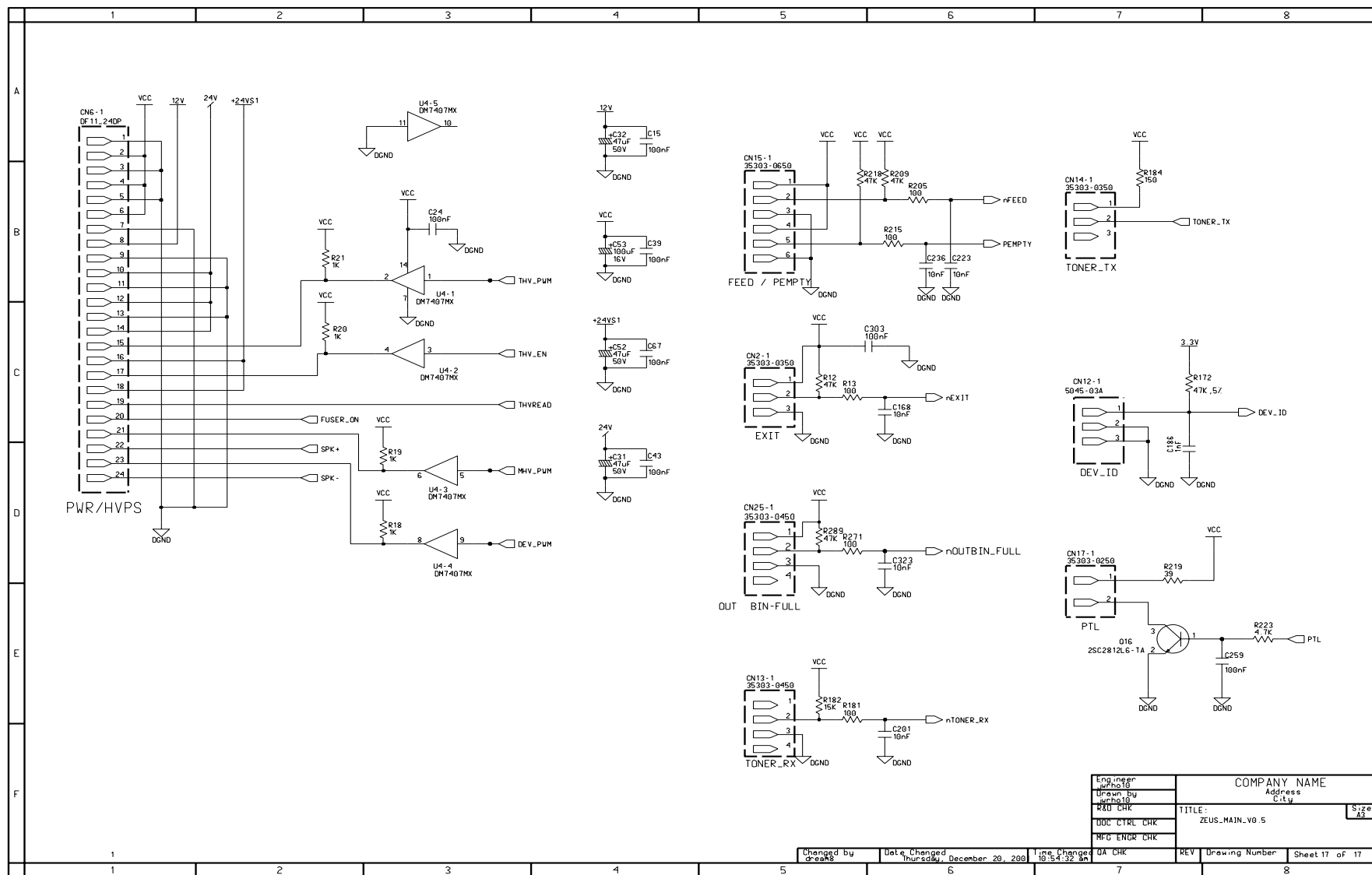

- This Document can not be used without Samsung's authorization -

4-2 LIU Circuit Diagram

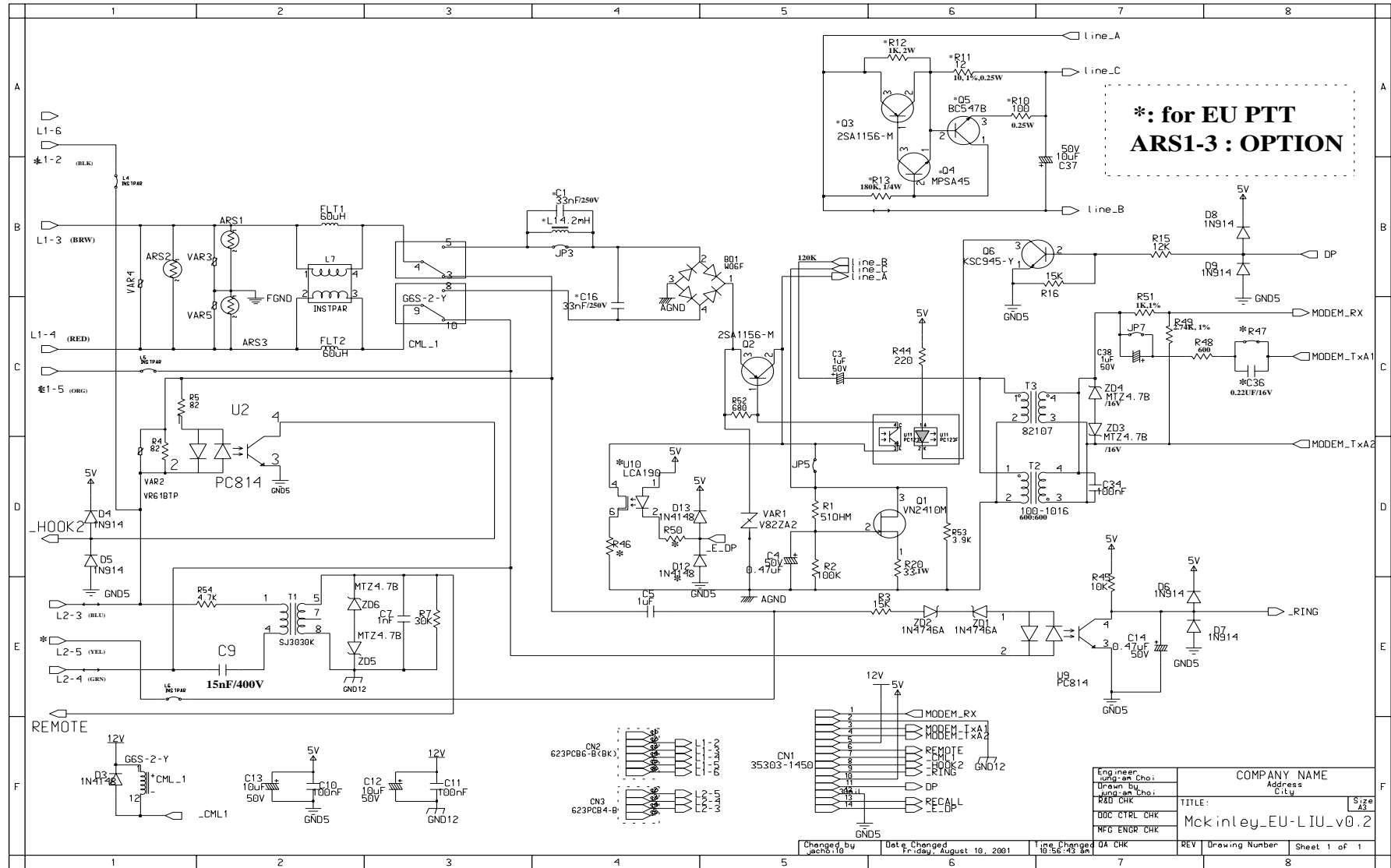

4-3 OPE Circuit Diagram

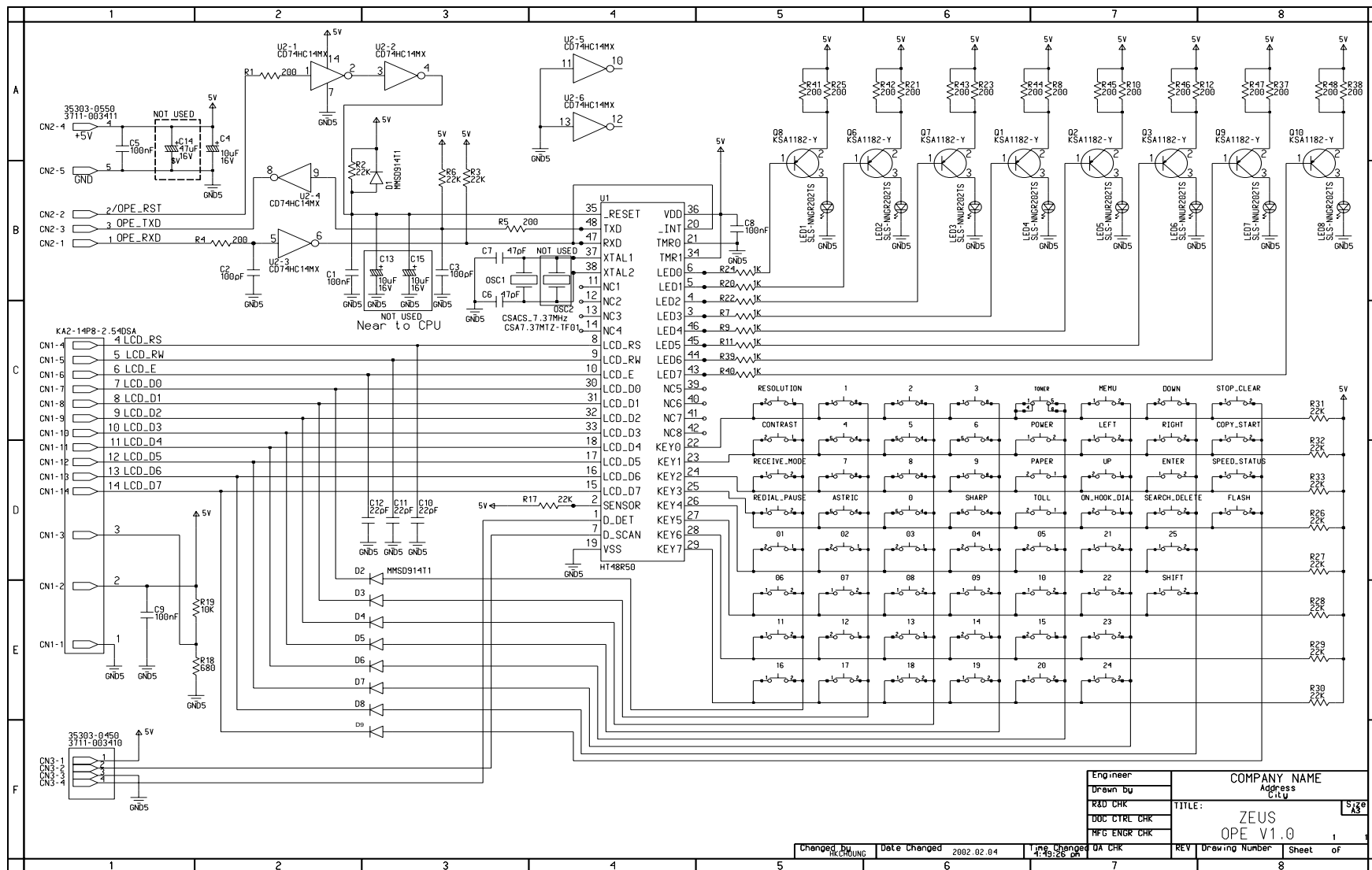

Engineer	COMPANY NAME	
Drawn by	Address	City
R&D CHK	TITLE:	Size
DDC CTRL CHK	ZEUS	A3
RF C ENGR CHK	OPE V1.0	
Changed by	Date Changed	Time Changed
AKC/BJG	2002.02.04	4:49:26 pm
REV	Drawing Number	Sheet of
1		1 of

4-4 Scan Circuit Diagram

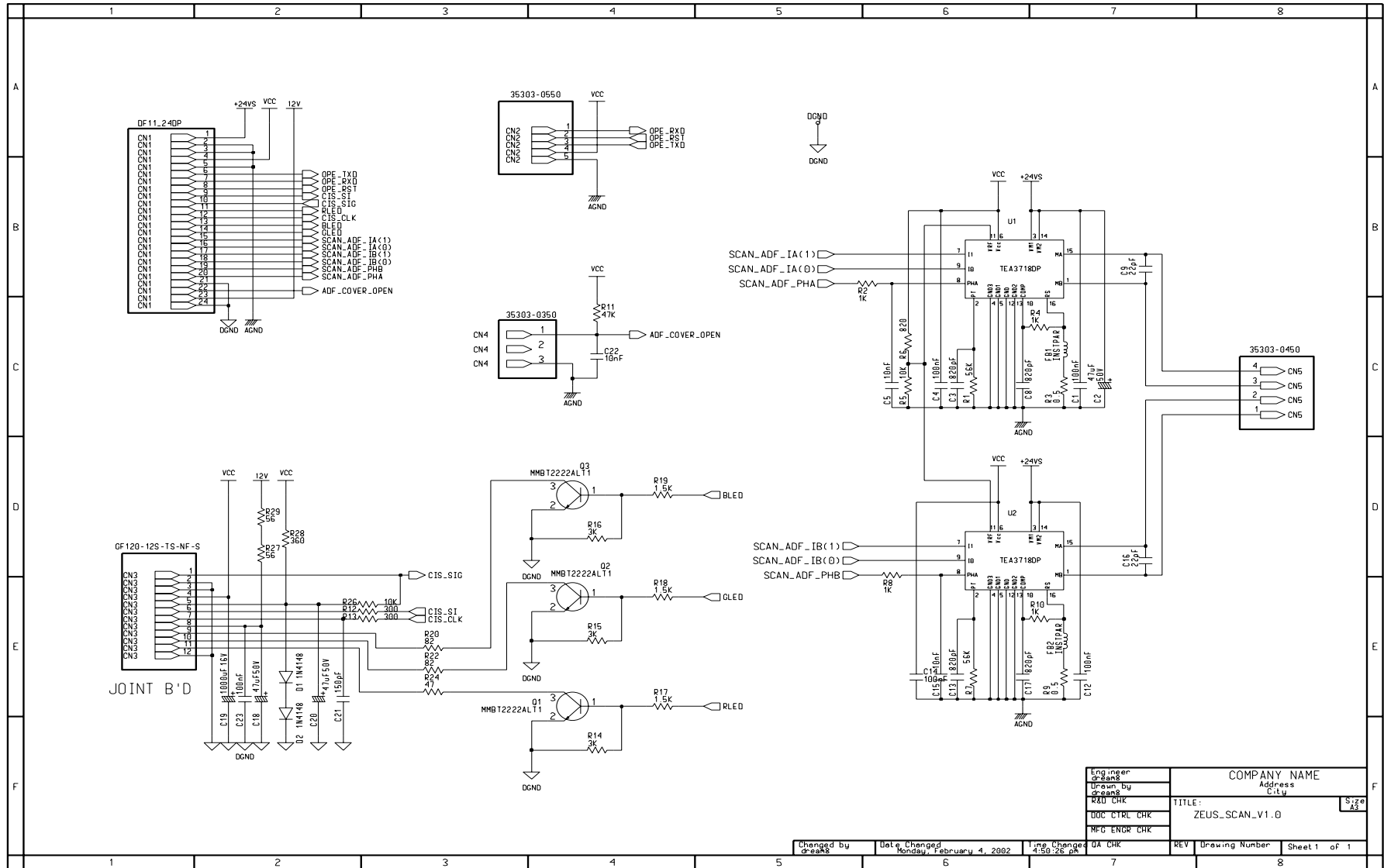

Engineer	COMPANY NAME
Drawn By	Address
Rev. No.	City
DOC. CTRL. CHR.	TITLE: ZEUS_SCAN_V1.0
MFG. ENGR. CHR.	REV. 1.0

Changed by	Date Changed	Time Changed	DA CHK	REV	Drawing Number	Sheet 1 of 1
g-rahs	Monday, February 4, 2002	4:50:25 pm				

- This Document can not be used without Samsung's authorization -

4-5 Sensor Circuit Diagram

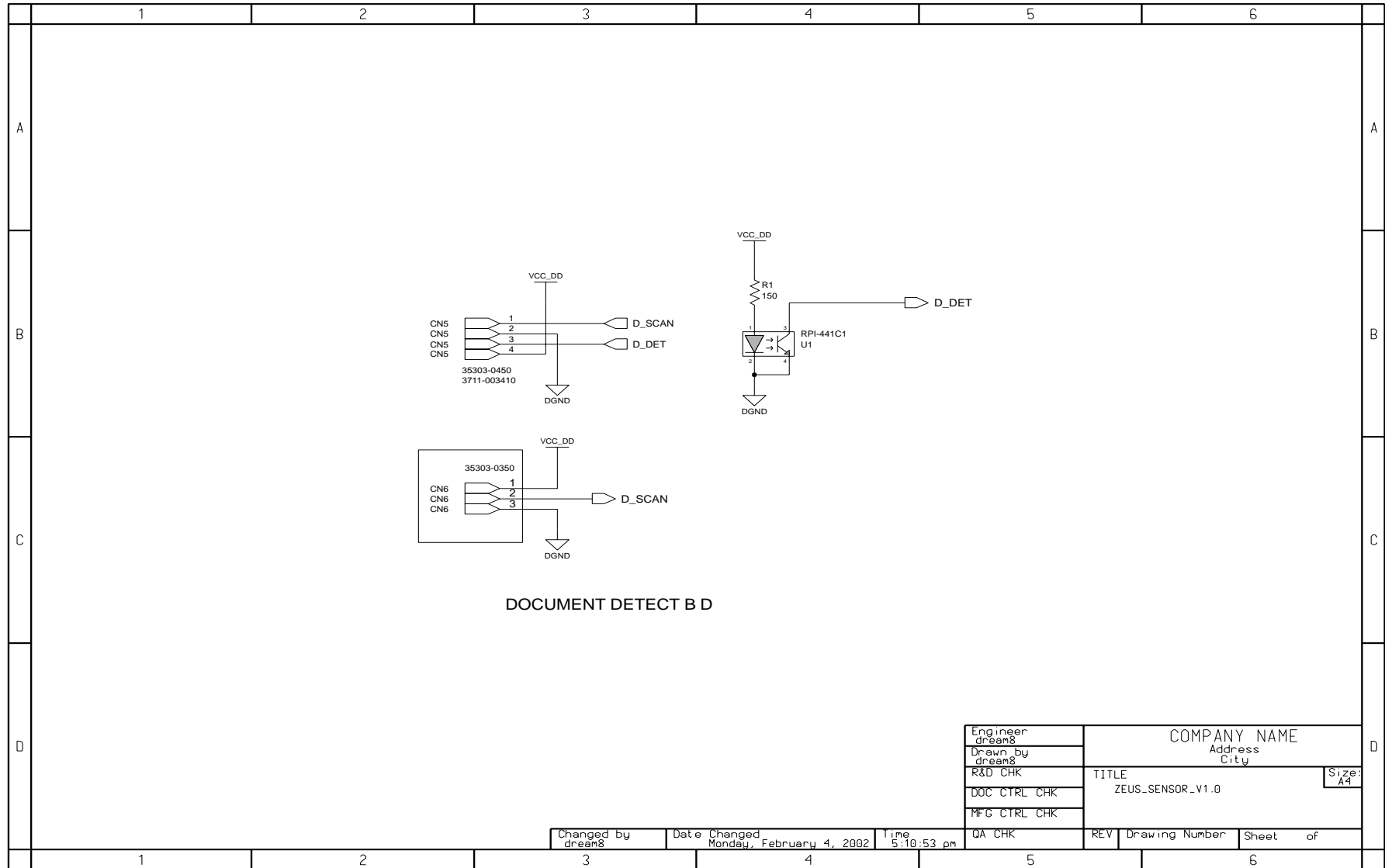

4-6 HVPS Circuit Diagram(1/2)

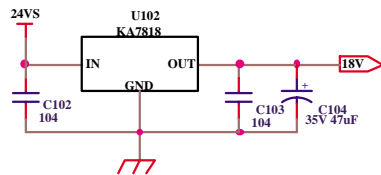
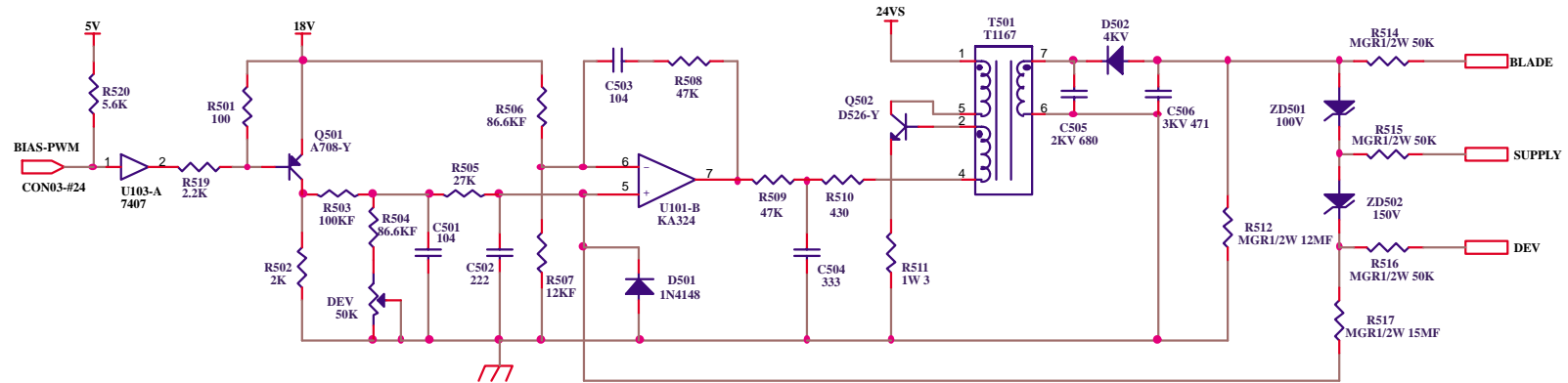
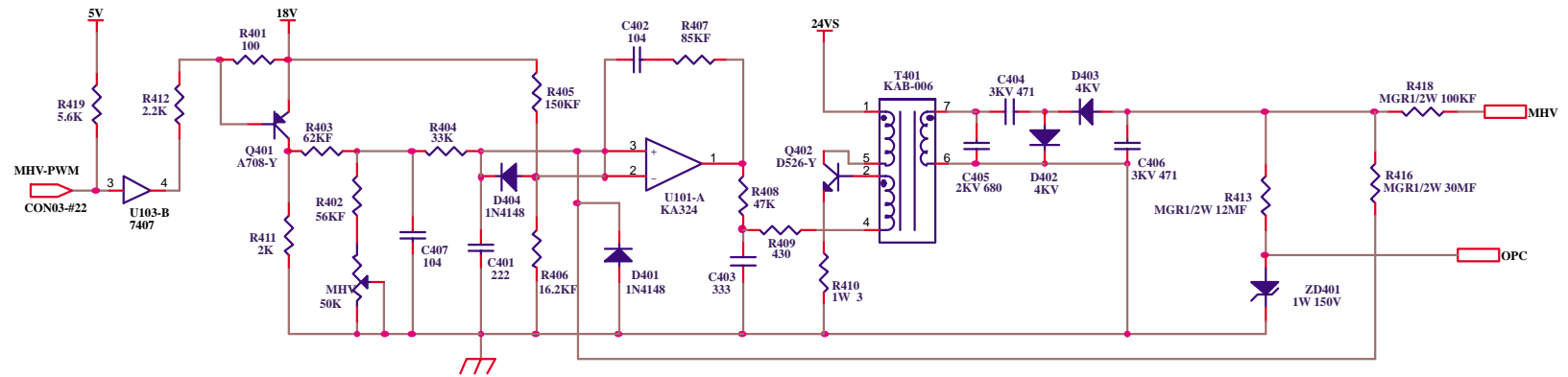

HVPS Circuit Diagram(2/2)

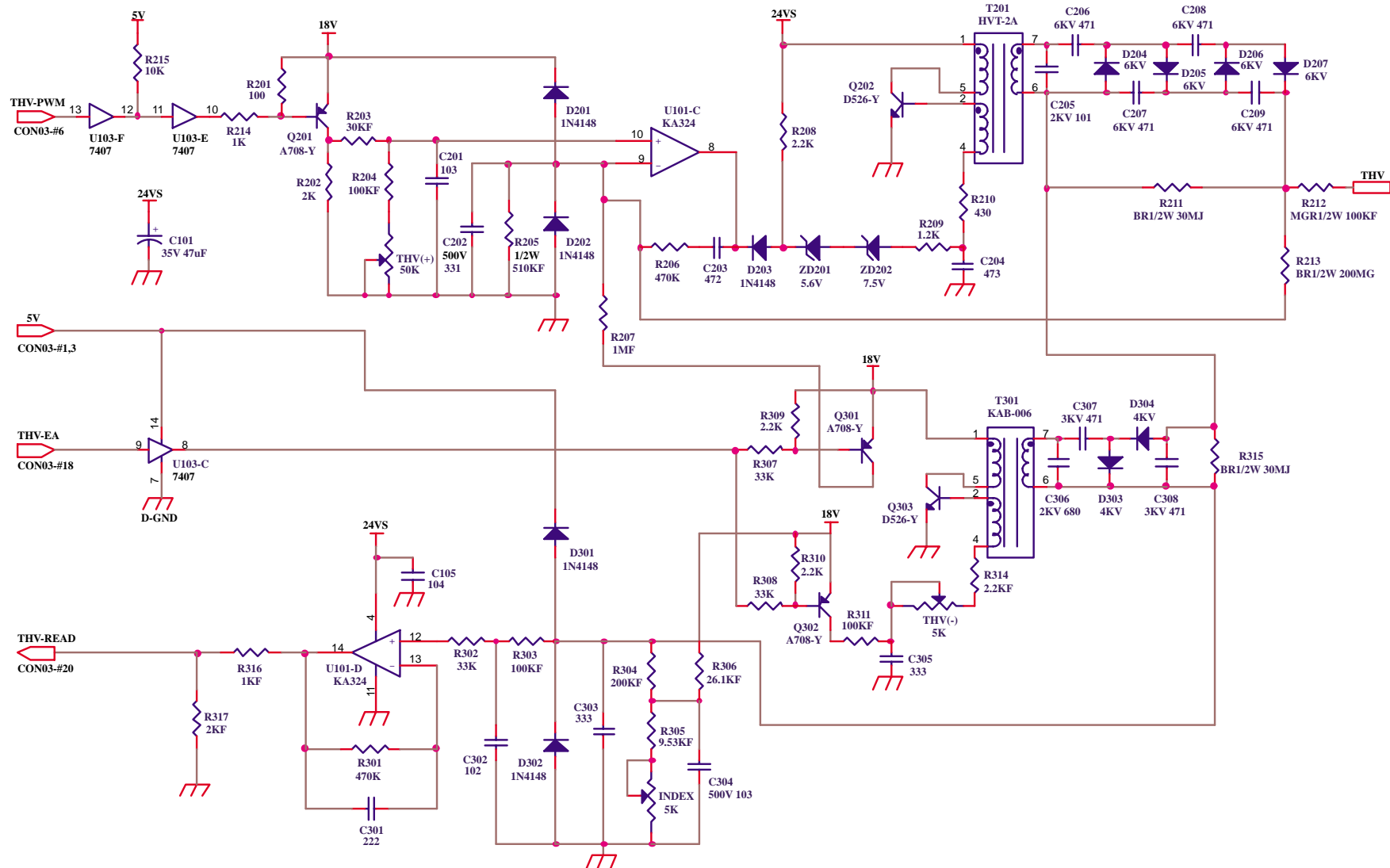

4-7 SMPS Circuit Diagram(110V)

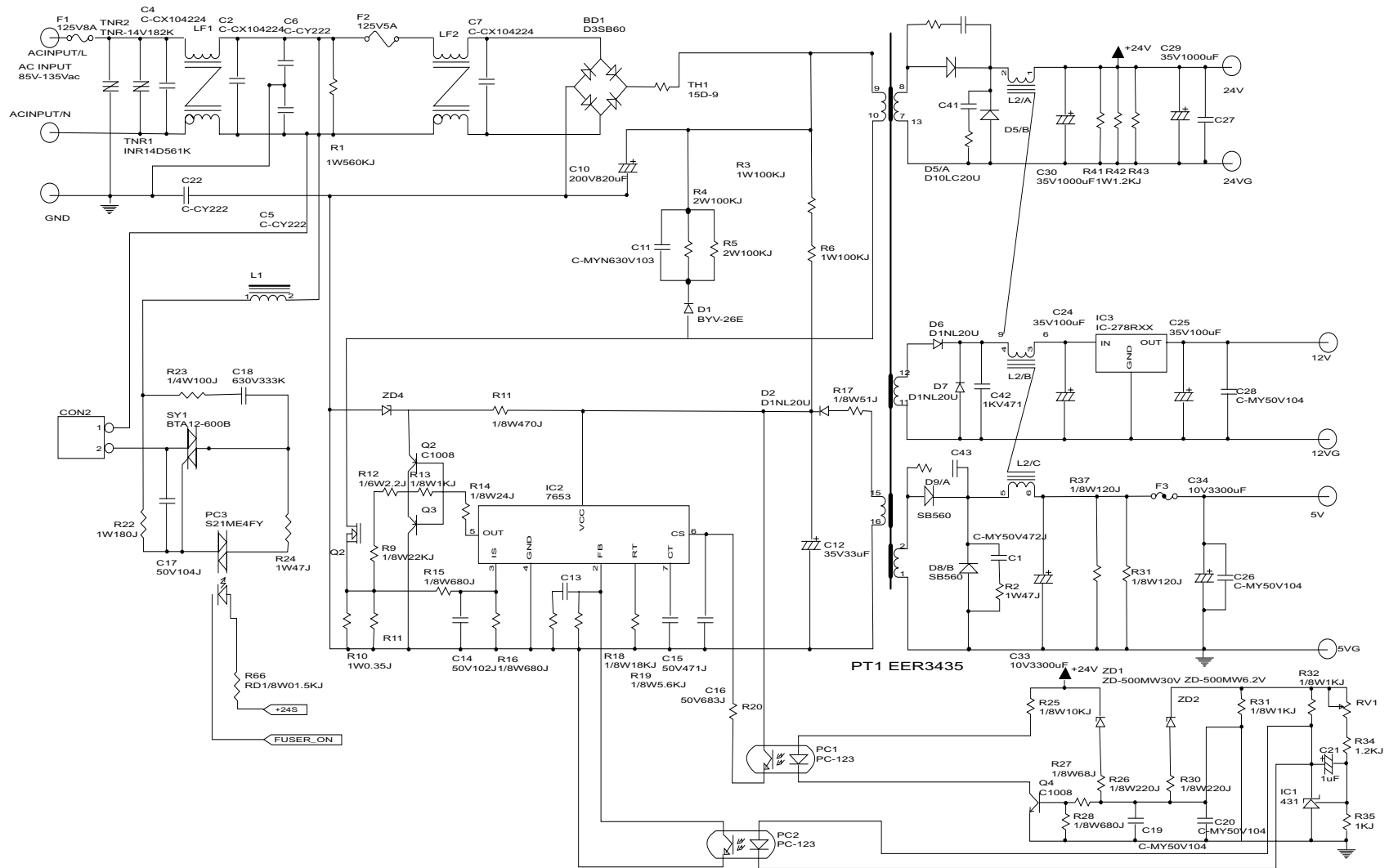

SMPS Circuit Diagram(220V)

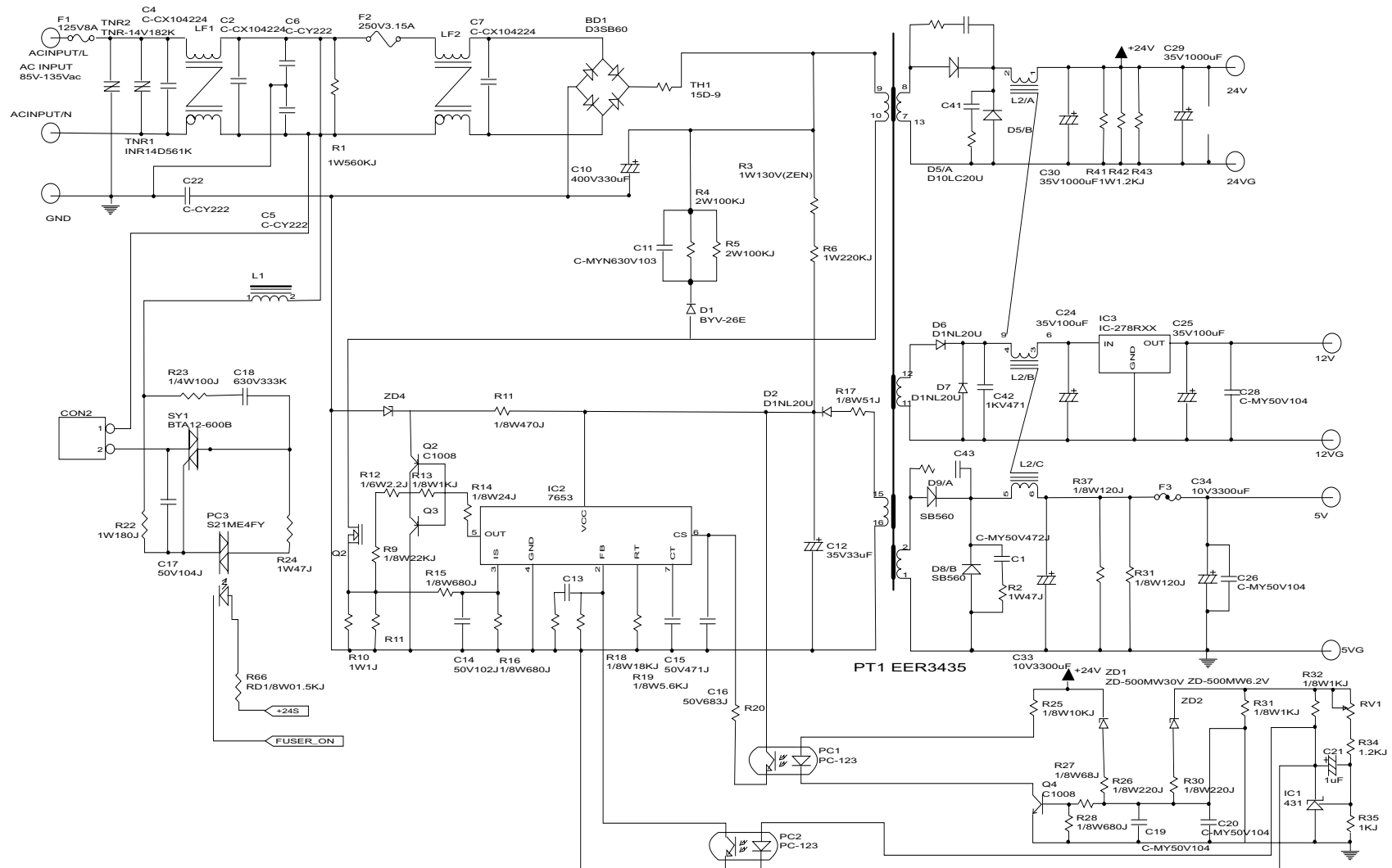

4-8 PTL Circuit Diagram

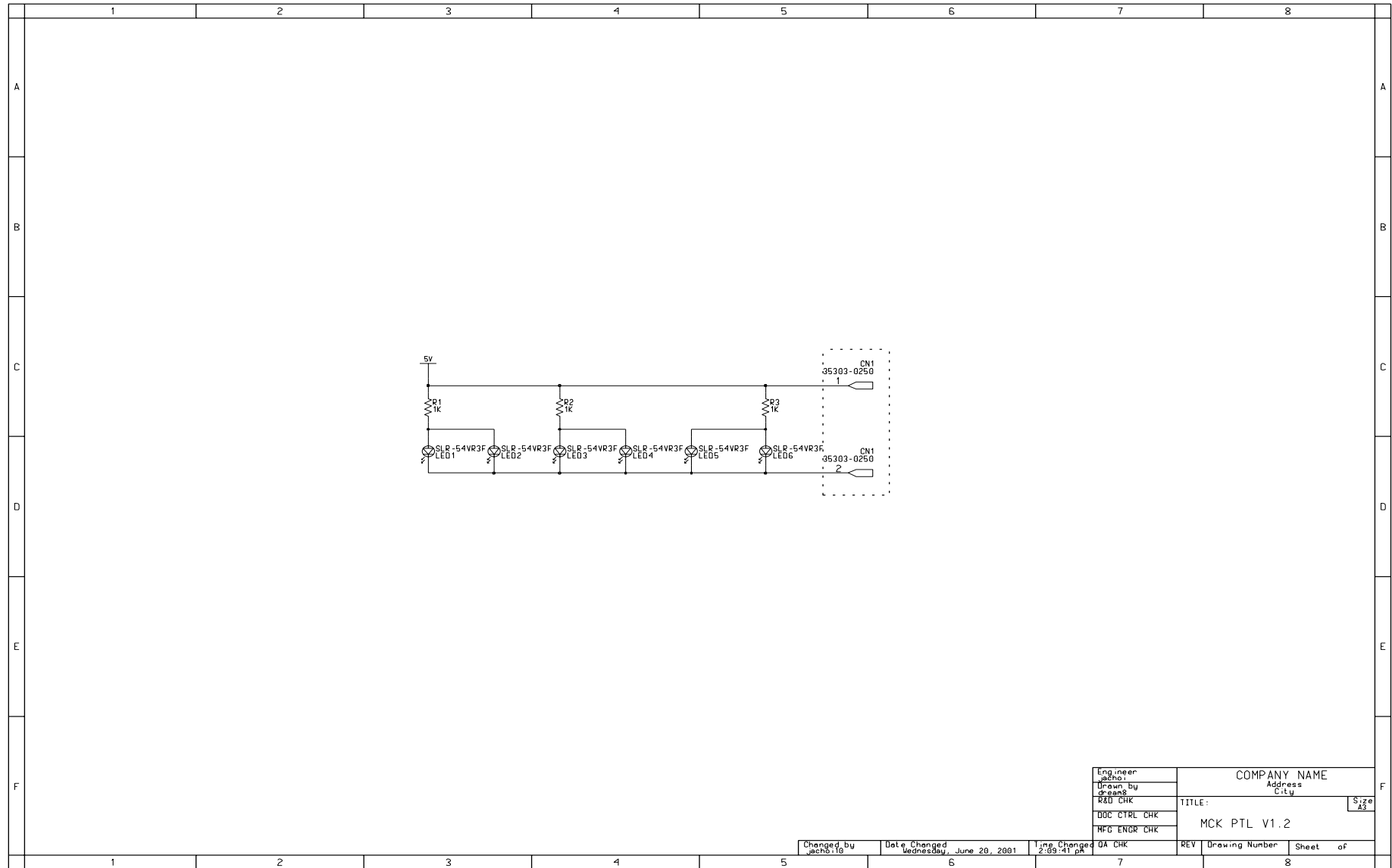

Engineer jchoi	COMPANY NAME	
Drawn by dream	Address City	
R&D CHK	TITLE: MCK PTL V1.2	Size A3
DOC CTRL CHK		
MFG ENGR CHK		

Changed by jchoi	Date Changed Wednesday, June 20, 2001	Time Changed 2:09:41 pm	QA CHK	REV	Drawing Number	Sheet of
---------------------	--	----------------------------	--------	-----	----------------	----------

- This Document can not be used without Samsung's authorization -

4-10 Toner\_Rx Circuit Diagram

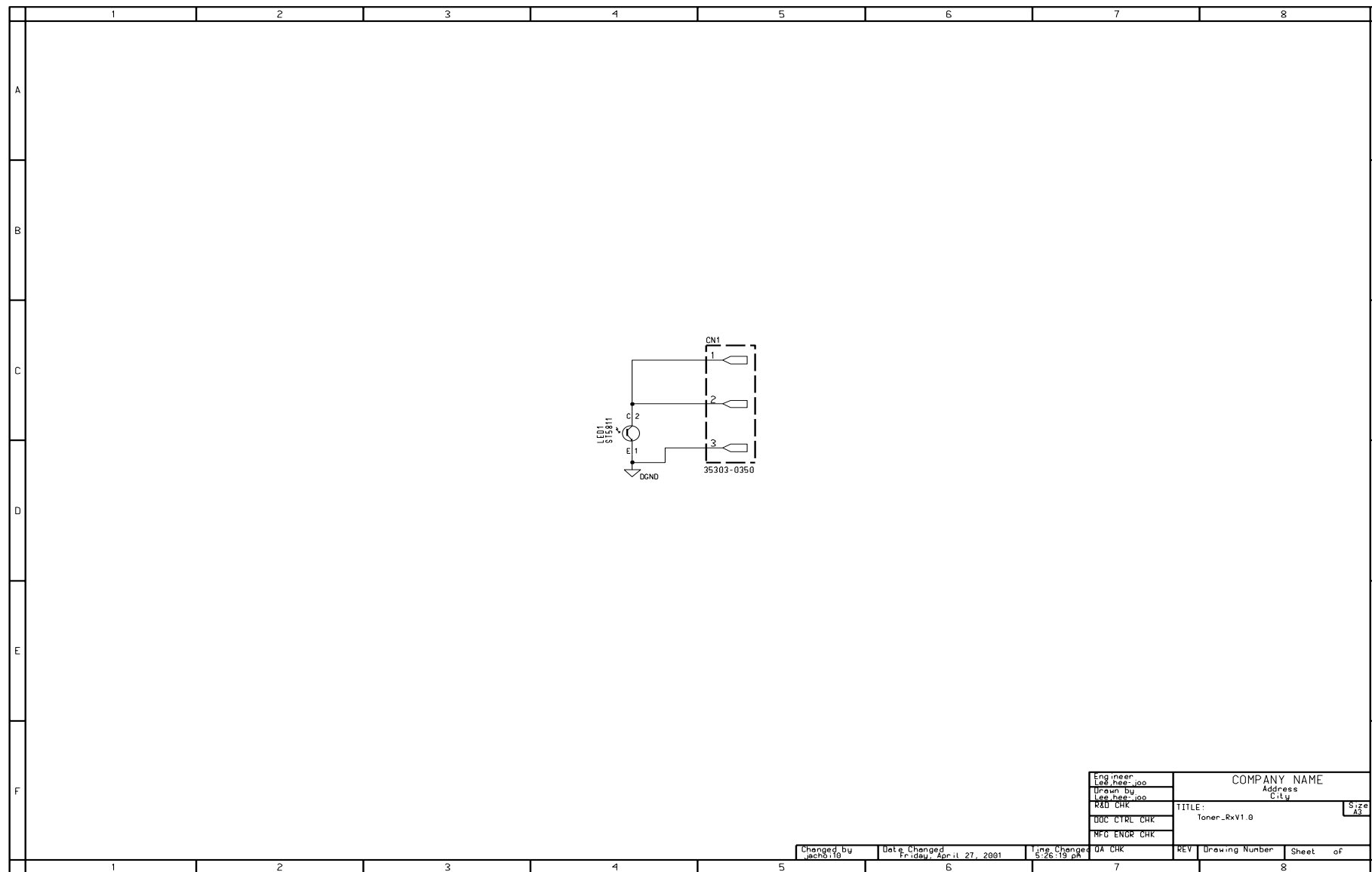

Engineer Lee,hee-do	COMPANY NAME	
Drawn by Lee,hee-do	Address	
R&D CHK	TITLE: Toner_RxV1.0	Size A3
DDC CTRL CHK		
MFG ENGR CHK		
DA CHK	REV	Drawing Number Sheet of

Changed by jcho110	Date Changed Friday, April 27, 2001	Time Changed 5:26:19 pm
-----------------------	--	----------------------------

4-11 Toner\_Tx Circuit Diagram

